



# Operating Instructions

**Monarch® 939i™ Intelligent Keyboard**  
for use with 9416® XL®, 9825®, 9855®, 9906™,  
and Avery Dennison® Tabletop Printer 1



Each product and program carries a respective written warranty, the only warranty on which the customer can rely. Avery Dennison Corp. reserves the right to make changes in the product, the programs, and their availability at any time and without notice. Although Avery Dennison Corp. has made every effort to provide complete and accurate information in this manual, Avery Dennison Corp. shall not be liable for any omissions or inaccuracies. Any update will be incorporated in a later edition of this manual.

©2004 Avery Dennison Corp. All rights reserved. No part of this publication may be reproduced, transmitted, stored in a retrieval system, or translated into any language in any form by any means, without the prior written permission of Avery Dennison Corp.

### **WARNING**

This equipment has been tested and found to comply with the limits for a Class A digital device, pursuant to Part 15 of the FCC Rules. These limits are designed to provide reasonable protection against harmful interference when the equipment is operated in a commercial environment. This equipment generates, uses, and can radiate radio frequency energy and, if not installed and used in accordance with the instruction manual, may cause harmful interference to radio communications. Operation of this equipment in a residential area is likely to cause harmful interference in which case the user will be required to correct the interference at his own expense.

### **CANADIAN D.O.C. WARNING**

This digital apparatus does not exceed the Class A limits for radio noise emissions from digital apparatus set out in the Radio Interference Regulations of the Canadian Department of Communications. Le présent appareil numérique n'émet pas de bruits radioélectriques dépassant les limites applicables aux appareils numériques de la classe A prescrites dans le Règlement sur le brouillage radioélectrique édicté par le ministère des Communications du Canada.

### **Trademarks**

Monarch®, 938, 939, 939i, 9416®, 9416® XL®, 9800®, 9825®, and 9855® are trademarks of Avery Dennison Retail Information Services LLC.

Avery Dennison® is a trademark of Avery Dennison Corporation.

UFST, Monotype, the Monotype logo, and CG Triumvirate are trademarks of Monotype Imaging, Inc.

Avery Dennison Printer Systems Division  
170 Monarch Lane  
Miamisburg, OH 45342

 Monotype Imaging



# TABLE OF CONTENTS

<b>GETTING STARTED</b> .....	<b>1-1</b>
Overview .....	1-1
Power-Up Modes .....	1-2
About This Manual .....	1-2
About Scripts .....	1-2
Unpacking the Keyboard .....	1-3
Connecting the 939I to a 9416 Printer .....	1-4
Connecting the 939I to a 9825® Printer .....	1-5
Connecting the 939I to a 9855®, 9906, or ADTP1 Printer .....	1-6
Setting the Baud Rate .....	1-7
Using the Keyboard .....	1-7
Control Keys .....	1-7
<b>SETTING BATCH OPTIONS</b> .....	<b>2-1</b>
Setting Prompts and Defaults .....	2-2
Non-Knife Setup .....	2-5
<b>ENTERING BATCH DATA</b> .....	<b>3-1</b>
Entering a Batch .....	3-2
Printing Tags Without Cutting .....	3-6
Using Print Multiple with Inc/Dec Fields .....	3-7
Examples .....	3-7
<b>TROUBLESHOOTING</b> .....	<b>4-1</b>
<b>SPECIFICATIONS &amp; ACCESSORIES</b> .....	<b>A-1</b>
Accessories & Options .....	A-1
Flat Surface Mount .....	A-2
Wall Mount .....	A-3
Connecting the Scanner's Cables .....	A-4

<b>CHARACTER SETS .....</b>	<b>B-1</b>
Supported Symbol Sets and Code Pages .....	B-1
Internal (Standard and Reduced Font) .....	B-2
Bold.....	B-3
ANSI .....	B-4
Code Page 437.....	B-5
Code Page 850.....	B-6
<b>CONFIGURING THE SYSTEM.....</b>	<b>C-1</b>
Accessing the Keyboard's Main Menu .....	C-1
Operating in Script Mode .....	C-1
About the Scanner .....	C-1
Operating the Scanner .....	C-2
Troubleshooting the Scanner .....	C-2
Cleaning .....	C-3
Configuring the Scanner .....	C-3
Reset to Default Values .....	C-3
Set the Communications Port Defaults.....	C-4
Set the Minimum Bar Code Width .....	C-6
<b>INDEX .....</b>	<b>I-1</b>

# GETTING STARTED

# 1

The Monarch® 939i™ keyboard allows you to easily configure the printer and enter batch data.

The keyboard works with the Monarch® 9416®, 9416® XL®, 9825®, 9855®, 9906, and Avery Dennison® Monarch® Tabletop Printer 1 (ADTP1) printers. This keyboard also works with non-Monarch printers. You may need an auxiliary power supply for the keyboard depending on your printer model. See Appendix A, “[Specifications and Accessories](#)” for the part number.

This chapter includes information about

- ◆ unpacking the keyboard.
- ◆ connecting the cables.
- ◆ power-up modes.
- ◆ using the keyboard.

## Overview

---

The 939i keyboard is an “intelligent” keyboard that can be programmed to show user prompts and collect data. Think of the intelligent keyboard like your PC, where you can enter data using your PC’s keyboard or connect an optional scanner to scan data.

Custom applications, or scripts, can be written to program the keyboard. The script is the program that runs on the keyboard to perform a specific task, such as scanning or collecting data. We offer custom script writing. Contact your Sales Representative for information and pricing on custom scripts.

With a script, you can

- ◆ Create prompts for the user to enter data manually or using a scanner. See Appendix C, “[Configuring the System](#),” for more information.
- ◆ Use look-up tables, or files, to store data that will be printed on labels.
- ◆ Perform additional data tracking, data conversion, and data manipulation.

## Power-Up Modes

---

If there is no script loaded in the keyboard, the keyboard operates in **terminal mode**. **Terminal mode is only available with the 9855 printer**. You can enter data and configure the printer. In terminal mode, the keyboard does not access the intelligent functionality provided by a script.

If a script is loaded in the keyboard, the keyboard operates in **“intelligent” mode**. The script automatically runs when the keyboard and printer are turned on. The prompts you see and what you do are controlled by the script. **“Intelligent” mode is available with the 9416®, 9416® XL®, 9825®, 9855®, 9906, and ADTP1 printers.**

## About This Manual

---

This manual is arranged in several sections:

- ◆ Use Chapters 2 through 4 when your keyboard is operating in terminal mode (9855 Printer Only).
- ◆ Use Appendix A for keyboard specifications.
- ◆ Use Appendix B for the available character sets.
- ◆ Use Appendix C, with information for your System Administrator on intelligent (script) mode and configuring the scanner.

The information in this document supersedes information in previous versions. Check our Web site for any updates.

## About Scripts

---

This manual does not cover any specific information about what may be in your script, because each script is different. Your script is written based on jobs you need to perform. A script should contain several basics features:

- ◆ A way to enter and exit the script.
- ◆ A way to enter terminal mode.
- ◆ The prompts for entering the date and time each time you turn on the printer if required by your script. The date and time are not saved when the printer/keyboard are turned off.
- ◆ The scanner’s configuration and setup (if you are using a scanner).

Contact your System Administrator for more information about these items.

## Unpacking the Keyboard

---

After unpacking the keyboard, look through all packaging material for parts. Keep the box and packaging material in case the keyboard ever needs repair.

1. Pull the long, coiled cable out from the bottom of the base.
2. Slide the first loop in the cable slot as shown.

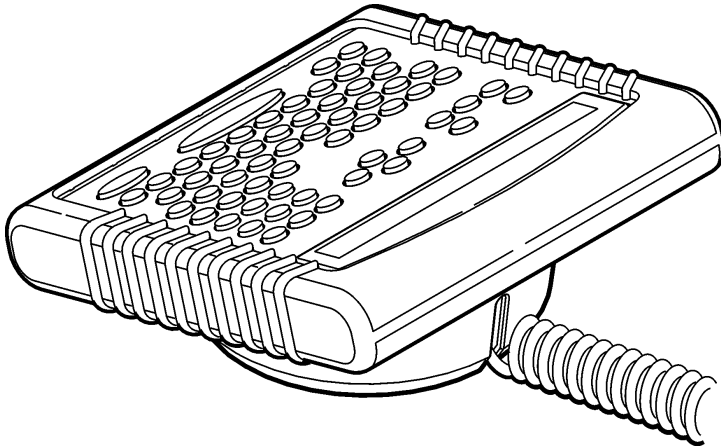

## Connecting the 939I to a 9416 Printer

---

When using the keyboard with a 9416 printer, the keyboard requires an auxiliary power supply with the 9-pin to 9-pin adaptor cable.

1. Turn **OFF** the printer before you connect the keyboard's cable.

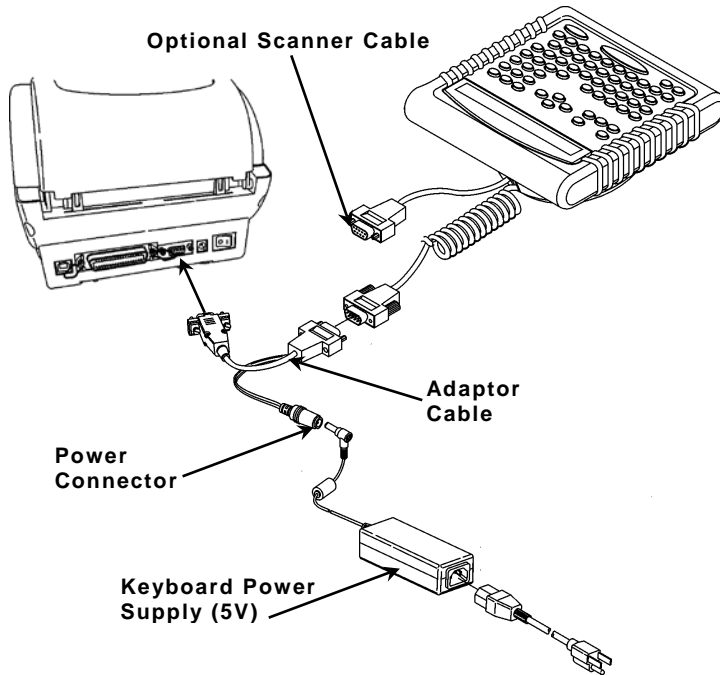

2. Plug the 9-pin coiled keyboard cable into the end of the adaptor cable.
3. Secure the other end of the adaptor cable to the 9-pin port on the printer. Tighten the screws on the cables.
4. Connect the adaptor cable's power connector to the keyboard power supply (5V).
5. Connect the keyboard power supply (5V) to the power cord.
6. Plug the power cord in to an electrical outlet.

**Note:** Be sure that the printer's power supply is also attached to the printer and plugged in to an electrical outlet.

7. Turn **ON** the printer. The keyboard receives power from the auxiliary power supply (5V).



## Connecting the 939I to a 9825® Printer

---

When using the keyboard with a 9825 printer, the keyboard requires an auxiliary power supply using the 9-pin to 25-pin adaptor cable.

1. Turn **OFF** the printer before you connect the keyboard's cable.

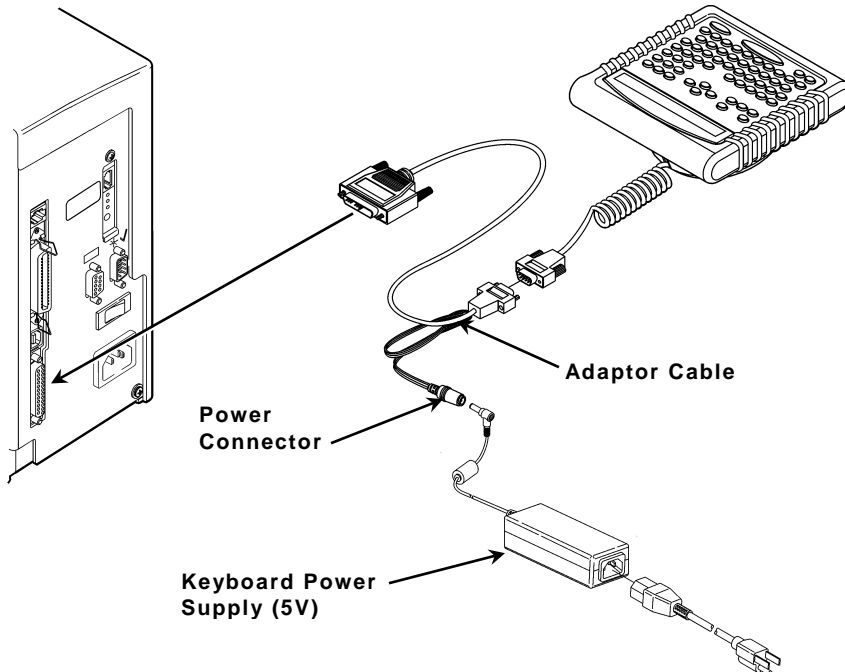

2. Plug the 9-pin coiled keyboard cable into the 9-pin to 25-pin adaptor cable.
3. Plug the 25-pin serial cable into the back of the printer.
4. Tighten the screws on the cables.
5. Connect the adaptor cable's power connector to the keyboard power supply (5V).
6. Connect the keyboard power supply (5V) to the power cord.
7. Plug the power cord in to an electrical outlet.
8. Turn **ON** the printer.

## Connecting the 939I to a 9855®, 9906, or ADTP1 Printer

When using the keyboard with a 9855, 9906 or ADTP1 printer, the keyboard receives power from the printer.

1. Turn **OFF** the printer before you connect the keyboard's cable.

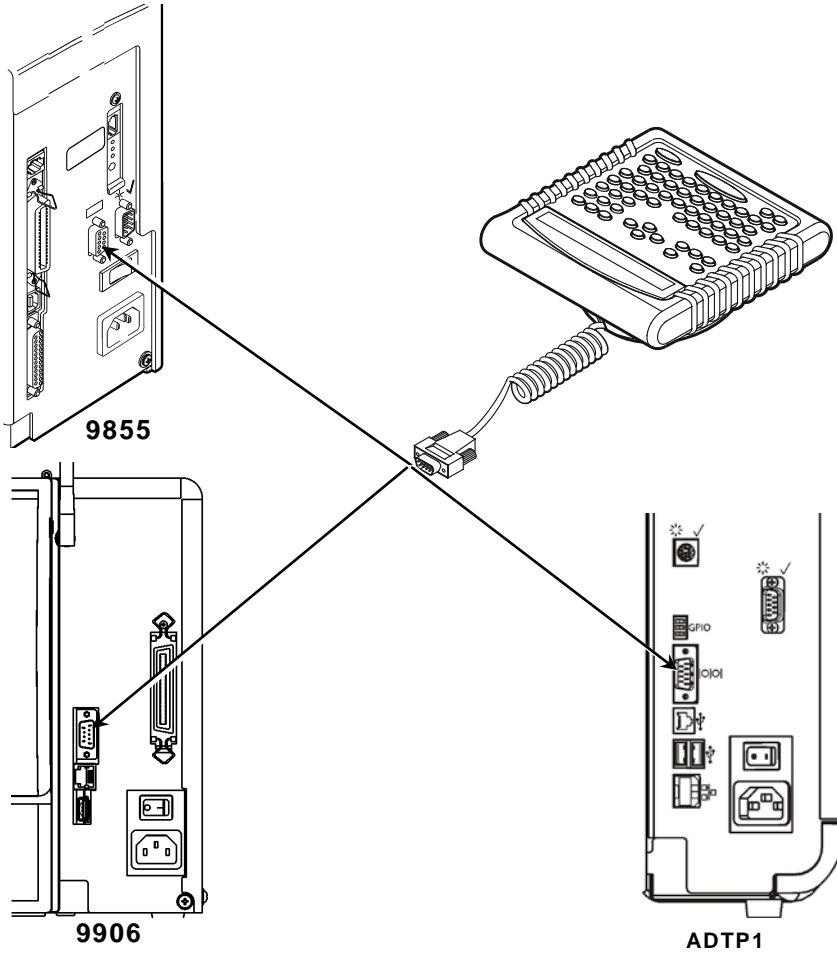

2. Plug the 9-pin coiled keyboard cable into the back of the printer.
3. Tighten the screws on the cables.
4. Turn **ON** the printer.

## Setting the Baud Rate

---

To print, the baud rate of the keyboard and printer must be the same. The default printer baud rate is 9600; the default keyboard baud rate is 19200. Refer to the *Operator's Handbook* or *System Administrator's Guide* for your printer to change the printer baud rate to 19200.

## Using the Keyboard









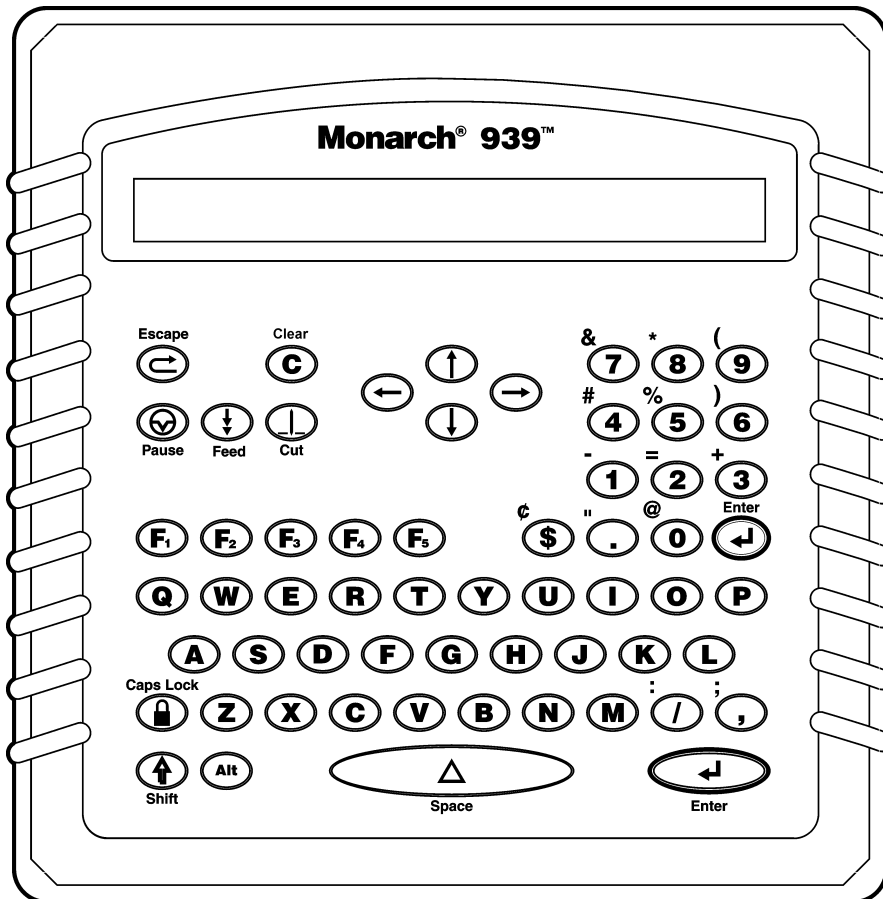



---

The keyboard has full alphabetic keys with 10 numeric keys, 5 function keys, 4 arrow keys, and several special keys.

### Control Keys

⏏, ⏴, and ⏵ operate as described in terminal mode. Depending on your script, those buttons may function differently.



Button	Description
	Escape. Returns the display to the previous menu or clears an error.
	Clear. Clears the entire field.
	Pause. Interrupts printing. Press Pause again to resume printing.
	Feed. Feeds a blank label if there is no print job. Prints a label in on-demand mode.
	Cut. Cuts the supply.
	Displays menu items and allows you to move the cursor.
	Moves between fields in Batch Entry.
	Enter. Selects the displayed menu item.
	Shift. Toggles between upper and lower-case. Use with other keys to display ¢, “, @, :, ;, -, =, +, #, %, (, ), &, *.
	Functions keys are reserved for script use. Depending on your script, <b>F1</b> may print a set of test labels or exit the application.
	Caps Lock. Allows you to type all upper-case characters (a padlock symbol is displayed in the corner).
	Enters an international character for printing when pressed and held along with a character code. See Appendix B, “ <a href="#">Character Sets</a> ” for the character codes.
	Space. Inserts a blank space between characters.

# SETTING BATCH OPTIONS

## 2

This chapter only applies when using the keyboard in terminal mode (9855 printer only). When using the keyboard in intelligent mode, your script controls the prompts you see and each script is different.

You can select Batch Options to change which prompts appear during Batch Entry mode and set default values for those prompts. Customizing which prompts appear during batch entry can reduce the time it takes to enter data for a format.

If a knife is not installed on the printer, you can prevent those prompts from appearing during batch entry mode. If you set a new default value for an option, that value is used even if the prompt is not displayed. If you do not change a default value for an option, the system default is used if the prompt is not displayed.

### Main Menu

Cancel All	Print Mode	Batch Entry	Repeat Batch	Batch Options	Setup	Scripts	Diag.
------------	------------	-------------	--------------	---------------	-------	---------	-------

Option	Default
Clear Fields	No
Number of Parts	1
Print Multiple	1
Quantity	1
Cut Option	No
Cut Multiple	1
Cut Last Ticket	No

## Setting Prompts and Defaults

---

Use the following steps to customize which prompts appear during batch entry and to specify defaults for these prompts.

1. Press **Enter** at the Main menu, when you see Batch Options. If you have password protection enabled, you see

Enter Password: -----
--------------------------

2. Press Feed three times and then press **Enter**.

Clear Fields? Prompt? Yes
------------------------------

3. Decide if you want to see this prompt in Batch Entry mode and press either  $\ominus$  or  $\omin�$  to display your selection. Press **Enter**.

Clear Fields? No $\rightarrow$
-----------------------------------

4. Decide if you want to change the default (No) and press either  $\ominus$  or  $\omin�$  to display your selection. Press **Enter**.

Number of parts Prompt? Yes
--------------------------------

5. Decide if you want to see this prompt in Batch Entry mode and press either  $\ominus$  or  $\omin�$  to display your selection. Press **Enter**.

Number of parts [1/5]: +1
------------------------------

6. Decide if you want to change the default (1) part printed across the supply. Press  $\omin�$  to change the number of parts (1-5). Press **Enter**.

Cut Option Prompt? Yes
---------------------------

7. Decide if you want to see this prompt in Batch Entry mode and press either  $\ominus$  or  $\omin�$  to display your selection. Press **Enter**.

Cut Option No $\rightarrow$
--------------------------------

8. Decide if you want to change the default (No) and press either  or  to display your selection. Press **Enter**.

Cut Multiple Prompt? Yes
-----------------------------

9. Decide if you want to see this prompt in Batch Entry mode and press either  or  to display your selection. Press **Enter**.

Cut Multiple 1 _____
-------------------------

10. Decide if you want to change the default (1) tag printed before cutting. **Enter** a quantity (1-32000). Press **Enter**.

**Note:** To cut between batches, make the Cut Multiple the same as the print quantity.

Cut Last Ticket? Prompt? Yes
---------------------------------

11. Decide if you want to see this prompt in Batch Entry mode and press either  or  to display your selection. Press **Enter**.

Cut Last Ticket? No <input type="radio"/>
--

12. Decide if you want to change the default (No) and press either  or  to display your selection. If you select “Yes,” the last tag in the batch is cut. The printer must feed one or two tags past the printhead to cut the last tag in the batch. Press **Enter**.

Cut After Batch? Prompt? Yes
---------------------------------

13. Decide if you want to see this prompt in Batch Entry mode and press either  or  to display your selection. If you select “Yes,” the last tag in the batch is cut. The printer must feed one or two tags past the printhead to cut the last tag in the batch. Press **Enter**.

Cut After Batch? No <input type="radio"/>
--

14. Decide if you want to change the default (No) and press either  $\leftarrow$  or  $\rightarrow$  to display your selection. If you select “Yes,” the knife cuts before the first tag and cuts after batch, so the tags are cuts in strips. Press **Enter**.

```
No Cut Before?  
Prompt? Yes
```

15. Decide if you want to see this prompt in Batch Entry mode and press either  $\leftarrow$  or  $\rightarrow$  to display your selection. Press **Enter**.

```
No Cut Before?  
No          →
```

16. Decide if you want to change the defaults (No) and press either  $\leftarrow$  or  $\rightarrow$  to display your selection. If you select “Yes,” the knife does not cut before the first tag in a batch, but does cut between each tag and after the last tag in a batch. Press **Enter**.

```
Quantity?  
Prompt? Yes
```

17. Decide if you want to see this prompt in Batch Entry mode and press either  $\leftarrow$  or  $\rightarrow$  to display your selection. Press **Enter**.

```
Quantity  
1 _ _ _ _ _
```

18. Decide if you want to change the default (1) for the quantity of tags to print in a batch. Enter a quantity (1-32000). Press **Enter**.

After setting the batch options, you are ready to use Batch Entry mode to enter data for your formats. See Chapter 3, “[Entering Batch Data](#),” for more information.



## Non-Knife Setup

If you do not have a knife attached to the printer, you are prompted for Print Multiple, instead of Cut Multiple.

```
Print Multiple
Prompt? Yes
```

1. Decide if you want to see this prompt in Batch Entry mode and press either  $\leftarrow$  or  $\rightarrow$  to display your selection. Press **Enter**.

```
Print Multiple
1 _ _ _ _ _
```

2. Decide if you want to change the default (No) for the number of copies of each tag to print as a set within a batch. Enter a quantity (1-32000). Press **Enter**.

```
Quantity?
Prompt? Yes
```

3. Decide if you want to see this prompt in Batch Entry mode and press either  $\leftarrow$  or  $\rightarrow$  to display your selection. Press **Enter**.

```
Quantity
1 _ _ _ _ _
```

4. Decide if you want to change the default (1) for the quantity of tags to print in a batch. Enter a quantity (1-32000). Press **Enter**.

After setting the batch options, you are ready to use Batch Entry mode to enter data for your formats. See Chapter 3, "[Entering Batch Data](#)," for more information.

Keep in mind the following definitions:

**Number of Parts**      Number of times data prints across the tag's width. Using one to print data once on the tag. Using three to print data three times across the tag.

**Cut Multiple**      Number of tags printed between cuts as a set. A cut multiple of one cuts after each tag. To cut after each batch, set the cut multiple equal to the print quantity. If the cut multiple is three and the print quantity is 15, five sets of three tags are printed and cut (15 tags). If the cut multiple is three and the print quantity is 16, five sets of three tags and one set of one tag are printed and cut (16 tags).

**Note:** The cut multiple does NOT effect the printed quantity.

**Print Multiple**      Number of copies of each tag to print as a *set* within a batch. A print multiple of one prints one set of one tag. A print multiple of three prints three copies of each tag as a set.

If the print multiple is three and the print quantity is 15, then 15 *sets* of tags with three tags *per set* are printed (45 tags). If the print multiple is two and the print quantity is four, then four *sets* of tags with two tags *per set* are printed (8 tags).

The most common application for print multiple is with incrementing or decrementing fields. See "[Using Print Multiple with Inc/Dec Fields](#)" for more information.

**Note:** The print multiple DOES effect the printed quantity.

**Print Quantity**      Number of tags or *sets* of tags printed in a batch. A print quantity of 30 prints 30 tags when the print multiple is one.

**Set**      Number of tags to be printed together within a batch.

# ENTERING BATCH DATA

## 3

This chapter only applies when using the keyboard in terminal mode (9855 printer only). When using the keyboard in intelligent mode, your script controls the prompts you see and each script is different.

This chapter explains how to enter batch data from the keyboard. You can enter numbers, letters, and a variety of symbols (including punctuation and international characters) from the keyboard. See Appendix B, “[Character Sets](#)” for information about international characters.

**Note:** We do not recommend entering more than 100 characters in batch entry mode.

Some fields specifically require numeric or alphabetic data. If you try to enter numeric data for an alpha field, or alphabetic data for a numeric field, the printer does not accept the data. Type the correct data and press N.

To enter numeric data, press the key that shows the number you want. The screen displays the number and the cursor moves to the next position in the field. This is also how you enter a period (.), comma (,), or dollar sign (\$). To enter alpha characters, press the key that shows the letter you want. The screen displays the character and the cursor moves to the next position in the field.

Here is an example of how to enter the word Red.

**Note:** Not all fonts support lower-case letters.

1. Press and hold **Shift** while pressing the **R** key. An upper-case R appears on the display.
2. Press the **E** key. A lower-case e appears on the display.
3. Press the **D** key. A lower-case d appears on the display.

When a field has fixed characters, they appear as part of the data entry prompt. The fixed data stays the same, and prints on every tag that uses the format. Only the data you enter can be changed. In the example below, the first six digits are fixed characters.

UPCA Barcode: 004156 _ _ _ _ _
-----------------------------------

The printed field contains both the fixed characters and the data you enter.

## Entering a Batch

---

Batch Entry lets you enter the data to print a batch (or batches) of supplies. You must first download your formats to the printer.

**Note:** Depending on your settings in Batch Options, some of these prompts may or may not appear. See Chapter 2, “[Setting Batch Options](#)” for more information.

1. Press **Escape** until you see the Main menu.
2. Press  $\leftarrow$  or  $\rightarrow$  until you see

MAIN MENU
$\leftarrow$ Batch Entry $\rightarrow$

3. Press **Enter**. You see

Select Format:
FMT-1 $\rightarrow$

4. Press  $\leftarrow$  or  $\rightarrow$  until you see the name of the format you want, then press **Enter**. You can also type the first letter of the format name and the display jumps to formats beginning with that letter.

5. Depending on your settings in Batch Options, you may see

Clear Fields? No <span style="float: right;">→</span>
--

- ◆ Press **Enter** (No) to keep the old data. Each field appears with the previous data. You can press **Enter** to accept the data, or change it and press **Enter**.
  - ◆ Press  $\leftarrow$  then press **Enter** (Yes) to erase the old data. Each field appears with blanks (underscores). You have to enter new data for each field.
6. You see the first prompt for the format. For example

Color: -----
-----------------

7. Type Red and press **Enter**.

Price: -----
-----------------

8. Type \$99.99 and press **Enter**. (Depending on your format, you may not need to type the dollar sign.)
9. Continue entering data for each prompt and press **Enter** when finished. If you make a mistake, you can clear the entire field by pressing Clear or use  $\leftarrow$  or  $\rightarrow$  to move the cursor to the character to change.

**Note:** You can also use  $\uparrow$  or  $\downarrow$  to move between fields.

10. After you enter data for all the fields, the prompts you see next varies, because you can choose to display or not to display certain prompts.

You may see

Number of parts? [1/5]: _
------------------------------

11. Type the number of times the data prints across the tag width. Press **Enter**.

Cut Option No →
--------------------

- ◆ If your printer has a knife and you want to cut tags, press  $\ominus$  to display “Yes” and press **Enter**.
- ◆ If your printer does not have a knife, the Cut Option prompt does not appear. See “[Printing Tags Without Cutting](#)” for more information.

If you answered “Yes” to the cut option, you have several cut modes to select from.

Cut Mode	Description
Cut after tag (Cut Mode 1)	Cuts before first tag, cuts each tag, and cuts after last tag. Printed tags left between knife and printhead.
Cut after batch (Cut Mode 2)	Cuts before first tag, cuts after batch. Cuts in strips, not each tag. Printed tags left between knife and printhead.
Cut last ticket (Cut Mode 3)	Cuts before first tag, cuts each tag, cuts after the last tag and feeds one or two tags past the printhead when it cuts the last tag in the last batch.
No cut before (Cut Mode 4)	Does not cut before the first tag in a batch, but cuts between each tag and after the last tag in the batch. Printed tags left between knife and printhead.
Cut in Strips (Cut Mode 5)	Cuts before first tag, cuts after batch. Cuts in strips, not each tag. Feeds one or two tags past the printhead when it cuts the last tag in the batch.

If you do not specify a cut mode (cut last ticket, cut after batch, or no cut before), the knife cuts after each tag. This is the same as cut mode 1. The knife uses the last selected cut mode. For example, if you select “Cut Last Ticket” and then select “Yes” to “Cut After Batch,” the knife only cuts after each batch instead of after the last tag in the batch.

Cut multiple [1/32000]: 1 _ _ _ _
--------------------------------------

1. Type the number of tags to print before cutting and press **Enter**, or accept the default value of 1 by pressing **Enter**. A cut multiple of one cuts after each tag. This is the same as cut mode 1.

Cut Last Ticket: No →
--------------------------

2. If you want to cut the last tag in the batch, press  $\ominus$  to display “Yes” and press **Enter**. The printer feeds one or two tags past the printhead when it cuts the last tag in the last batch. Depending on the length of your supply, you may lose up to two tags after the last batch. This is the same as cut mode 3.

Cut After Batch: No →
--------------------------

3. If you want to cut after every batch, press  $\ominus$  to display “Yes” and press **Enter**. The knife cuts before the first tag and cuts after batch, so the tags are cuts in strips. This is the same as cut mode 2.

No Cut Before? No →
------------------------

4. If you do not want to cut before the first tag in a batch, press  $\ominus$  to display “Yes” and press **Enter**. The knife does not cut before the first tag in a batch, but does cut between each tag and after the last tag in a batch. This is the same as cut mode 4.

Quantity [1/32000]: 1 _ _ _ _
----------------------------------

5. Type the number of tags or sets of tags you want to print in this batch and press **Enter**. A cut multiple of two with a batch quantity of 30 prints 30 tags (15 sets of two tags).

Print Now? No →
--------------------

6. Select either “No” or “Yes” and press **Enter**. If you select “No,” the batch data is saved to print later and you return to the format selection prompt in Batch Entry mode. To print the format later, press **Enter** when you see “PRINT MODE Ready.”

If you select “Yes,” the batch begins to print. The display counts the tags as they print and how many tags are in the batch. After the batch prints, you return to the “Select Format” prompt in Batch Entry.

## Printing Tags Without Cutting

Depending on your settings in Batch Options, some of these prompts may or may not appear. See Chapter 2, “[Setting Batch Options](#)” for more information.

If you answered “No” to the cut option, you may see

Print Multiple [1/32000]: _ _ _ _ _
--

1. Type the number of copies of each tag to print as a set within a batch. If you want three copies of each tag, use a print multiple of 3. Press **Enter**.

Quantity [1/32000]: _ _ _ _ _
----------------------------------

2. Type the number of tags or sets of tags you want to print in this batch and press **Enter**. A print multiple of two with a batch quantity of 30 prints 60 tags (30 sets of tags with two tags per set).

Print Now? No →
--------------------

3. Select either “No” or “Yes” and press **Enter**. If you select “No,” the batch data is saved to print later and you return to the format selection prompt in Batch Entry mode. To print the format later, press **Enter** when you see “PRINT MODE Ready.”

If you select “Yes,” the batch begins to print and cut (if cut options were enabled). The display counts the tags as they print and how many tags are in the batch. After the batch prints, you return to the “Select Format” prompt in Batch Entry.



## Using Print Multiple with Inc/Dec Fields

If your tag has an incrementing or decrementing field, the print multiple is the number of tags printed as a set *before* incrementing or decrementing. If the incrementing field is set to 10, the print multiple is 2, and the print quantity is 2, then four tags are printed. Two tags print "10" in the incrementing field, the other two tags print "11" in the incrementing field.

### Examples

- ◆ Number of parts = 1, cut multiple or print multiple = 1, print quantity = 4: Four sets of one tag are printed (and cut after each tag if using cut multiple).
- ◆ Number of parts = 3, cut multiple = 2, print quantity = 2: Two tags are printed and cut after the second tag is printed.
- ◆ Number of parts = 3, print multiple = 2, print quantity = 2: Four tags are printed as two sets of two tags.
- ◆ Number of parts = 3, print multiple = 2, print quantity = 4: Eight tags are printed as four sets of two tags.

The following graphic shows the relationship between the number of parts, cut multiple, and print multiple.

Three-part tag  
(number of parts = 3) →

Cut here for a cut multiple of 1  
(Cut after one tag) OR  
Print multiple = 1 →  
(Prints one tag as a set)

Cut here for a cut multiple of 2  
(Cut after two tags) OR  
Print multiple = 2 →  
(Prints two tags as a set)

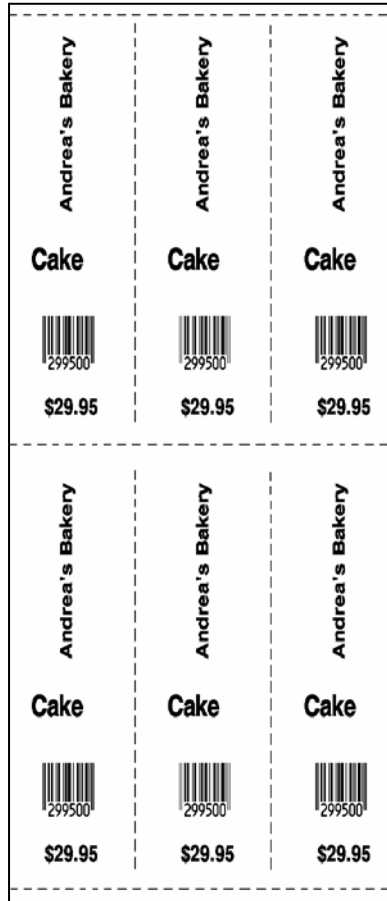

# TROUBLESHOOTING

## 4

This chapter provides solutions to keyboard problems and explains common status code messages you may receive when using the keyboard.

<b>Problem</b>	<b>Action</b>
The keyboard display is blank.	Make sure the printer is ON. Make sure the keyboard cable is securely attached to the printer. If the keyboard was attached while the printer was on, turn OFF the printer and then back ON.
The data you entered is not accepted.	Refer to your format for acceptable characters for this field. Some fields accept only letters, some accept only numbers, and some accept only specific ranges of letters or numbers.
Your data was not accepted and blanks are still showing.	This field requires data for all underscores shown. Enter the correct data and press <b>Enter</b> .
You entered an incorrect check digit.	The data and check digit must be the correct combination. Enter the correct data and press <b>Enter</b> .
You tried to skip a required field.	This field requires data before continuing to the next field. Enter data and press the <b>Enter</b> .
Letters are not in the expected case.	Make sure the Caps Lock (  ) is not on.

<b>Problem</b>	<b>Action</b>
Monetary symbols do not print as expected.	Make sure your font supports the selected code page (Bold, ANSI, etc.). For more information, see Appendix B, " <a href="#">Character Sets</a> ."
Script is not running.	Turn the printer off and then back on. If this does not solve the problem, contact Technical Support for more information.
Scanner does not work.	Make sure the scanner is connected and configured. See Appendix C, " <a href="#">Configuring the System</a> ," for more information.

# SPECIFICATIONS & ACCESSORIES

A

<b>Height:</b>	4.0 inches (102 mm)
<b>Width:</b>	8.25 inches (210 mm)
<b>Depth:</b>	8.75 inches (222 mm)
<b>Weight:</b>	2.33 lbs. (1.06 kg)
<b>Shipping Weight:</b>	3.4 lbs. (1.5 kg)
<b>Power Source:</b>	Supplied by printer or auxiliary power supply (5V)
<b>Memory:</b>	Flash; 128K maximum for scripts; 256K maximum for data collection and lookup files. There is no battery-backed RAM.
<b>Operating Limits:</b>	40° to 104°F (4° to 40°C) See your printer's documentation for the printer's operating range.

## Accessories & Options

---

- ◆ Keyboard stand. Can be used on a flat surface or mounted on a wall. When ordering, ask for the “keyboard stand” option.
- ◆ Scanner (126743) and scanner stand (125099).
- ◆ Auxiliary 5V Power Supply (129435) Used with a 9416 or 9825 printer or Non-Monarch printer.
- ◆ 9 to 9-pin Programming Cable (126660)
- ◆ 9 to 9-pin Cable (126701) used with a 9416 printer
- ◆ 9 to 25-pin Cable (126830) used with a 9825 printer

## Flat Surface Mount

Make sure all surfaces you apply the dual lock fasteners to are free from dirt and oil. If necessary, clean with isopropyl alcohol.

1. Pull the cord through the large hole in the stand.
2. Set the keyboard into the stand.
3. Attach either the rubber pads or dual lock fasteners to the base of the keyboard stand. If using the dual lock fasteners, attach the other side of the fastener to the tabletop.

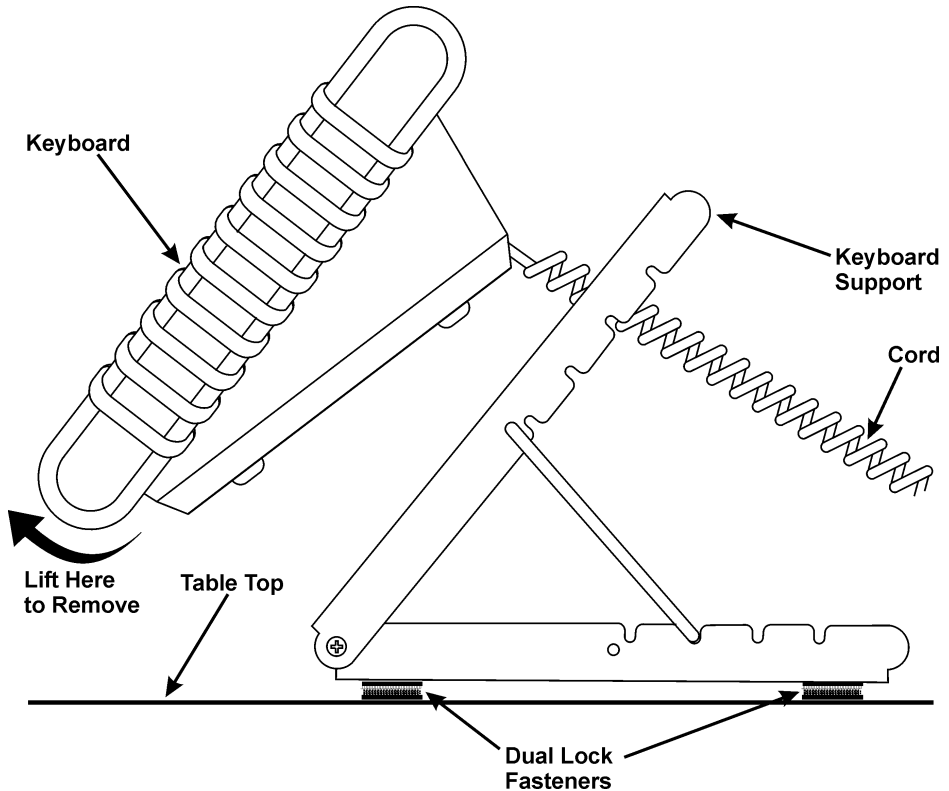

To remove the keyboard from the stand, lift the keyboard from the bottom.

## Wall Mount

1. Hold the bottom of the stand against the wall (hinge side up). Mark the mounting holes with a pencil.
2. Screw the stand onto the wall (screws not included).
3. Pull the cord through the large hole in the stand.
4. Set the keyboard into the stand.

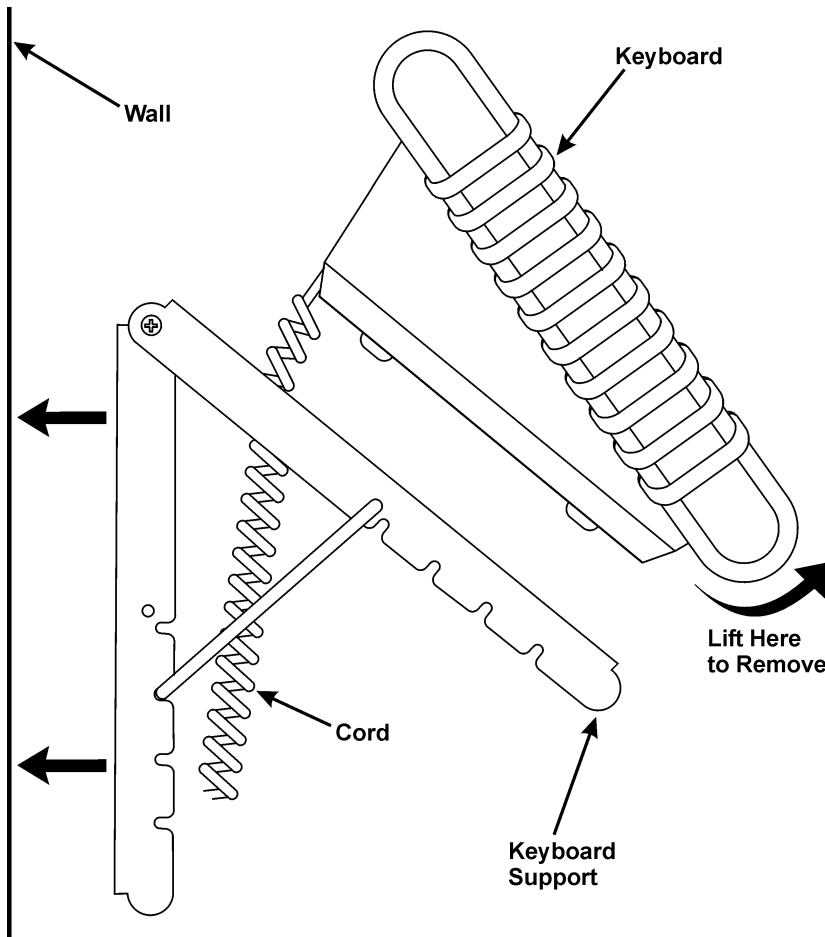

To remove the keyboard from the stand, lift the keyboard from the bottom.

## Connecting the Scanner's Cables

---

A scanner is optional for the keyboard. You need to connect the cable to the scanner and keyboard before you can use it. The scanner receives power through the keyboard. For more information about the scanner or other peripheral devices, refer to their *User Manuals*.

1. Turn OFF the printer before you connect the scanner's cable.

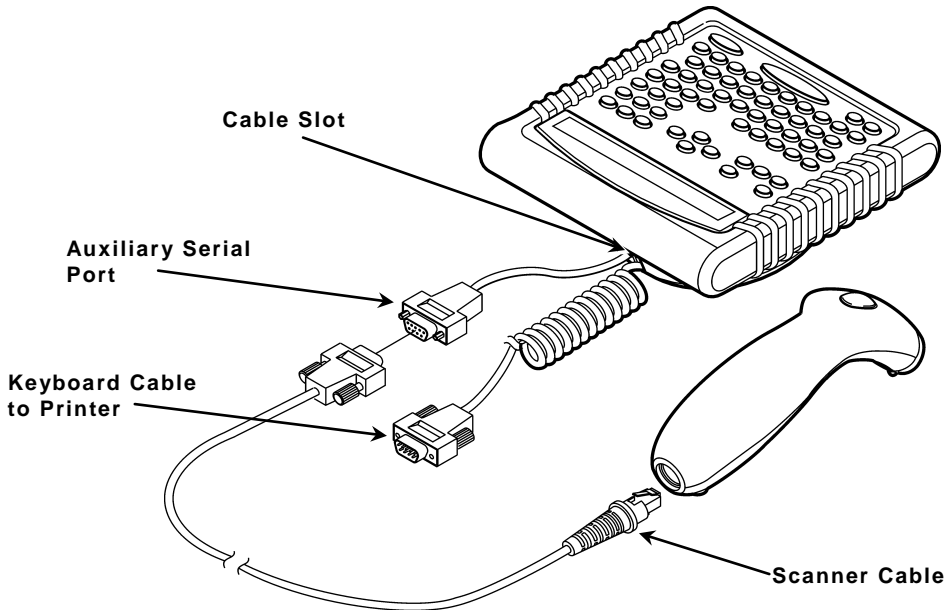

2. Reach into the bottom of the keyboard's base and locate the keyboard's auxiliary serial port, which is on a short, straight cable as shown.
3. Slide the cable into the slot on the keyboard's base.
4. On the scanner, connect the RJ45 male connector end of the cable into the scanner. You hear it click into place.
5. Connect the other end (9-pin male) of the cable to the keyboard's auxiliary serial port (9-pin female).
6. Tighten the screws on the cable to secure the scanner cable to the auxiliary serial port.
7. Tuck the connectors into the keyboard's base if necessary.
8. Turn ON the printer. Press (I) to turn on and (O) to turn off the printer.



# CHARACTER SETS

## B

This appendix contains a listing of the symbol sets and code pages the printer supports.

### Supported Symbol Sets and Code Pages

---

The CG Triumvirate™ typefaces support only the ANSI and DOS Code Page 437 and 850 Symbol Sets. These fonts print a slashed zero when using the ANSI symbol set. However, the scalable font does not print a slashed zero or support Code Page 1256 (Arabic).

Internal	Use this set to print international monetary symbols, the trademark (™) symbol, and for formats that may be used on other MPCLII printers.
ANSI	Use this set with proportionally spaced fonts.
DOS Code Pages 437 or 850	Use this set for extended and international characters with proportionally spaced fonts.

To enter a character code:

Press and hold **Alt**. Use the numeric keys to enter a three-digit character code. For example, press **Alt 179** for ¥.

The keyboard's display may not match the character printed.

If you selected monetary signs from the Setup, Defaults menu and use the Standard, Reduced or Bold font, the monetary symbols from the selected country will be printed. However, if using the CG Triumvirate™ typefaces, the monetary symbols may not print as expected. Make sure your font requirements are supported by the selected code page.

For additional code pages that your printer may support, refer to the *Packet Reference Manual* available on our Web site.



# Bold

240																
224																
208																
192	€															
176	\$	£	¥	¤	F	P	̄	ˆ	˚	‰	¢	₤	₳	₧	₪	₹
160											½					
144											¢					
128																
112																
96																
80	P	Q	R	S	T	U	V	W	X	Y	Z	[	\	]	^	_
64	@	A	B	C	D	E	F	G	H	I	J	K	L	M	N	O
48	0	1	2	3	4	5	6	7	8	9	:	;	<	=	>	?
32	!	”	#	\$	%	&	'	(	)	*	+	,	-	.	/	
16																
0																
	0	1	2	3	4	5	6	7	8	9	10	11	12	13	14	15

# ANSI

240	ð	ñ	ò	ó	ô	õ	÷	ø	ù	ú	û	ü	ý	þ	ÿ	
224	à	á	â	ã	ä	å	æ	ç	è	é	ê	ë	ì	í	î	ï
208	Ð	Ñ	Ò	Ó	Ô	Õ	×	Ø	Ù	Ú	Û	Ü	Ý	Þ	ÿ	
192	À	Á	Â	Ã	Ä	Å	Æ	Ç	È	É	Ê	Ë	Ì	Í	Î	Ï
176	°	±	²	³	´	µ	¶	·	¸	¹	º	»	¼	½	¾	¿
160	¡	¢	£	¤	¥	¦	§	¨	©	ª	«	¬	­	®	¯	
144	‘	’														
128																
112	p	q	r	s	t	u	v	w	x	y	z	{		}	~	☒
96	`	a	b	c	d	e	f	g	h	i	j	k	l	m	n	o
80	P	Q	R	S	T	U	V	W	X	Y	Z	[	\	]	^	_
64	@	A	B	C	D	E	F	G	H	I	J	K	L	M	N	O
48	0	1	2	3	4	5	6	7	8	9	:	;	<	=	>	?
32	!	"	#	\$	%	&	'	(	)	*	+	,	-	.	/	
16																
0																
	0	1	2	3	4	5	6	7	8	9	10	11	12	13	14	15

# Code Page 437

240	≡	±	≥	≤	[	]	÷	≈	°	·	·	√	n	²	■	
224	α	β	Γ	π	Σ	σ	μ	τ	Φ	Θ	Ω	δ	∞	φ	ε	∩
208	⌌	⌍	⌎	⌏	⌐	⌑	⌒	⌓	⌔	⌕	⌖	⌗	⌘	⌙	⌚	⌛
192	L	└	┘	┐	┌	└	┘	┐	┌	└	┘	┐	┌	└	┘	┐
176	⋮	⋯	⋰		├	┤	┥	┦	┧	┨	┩	┪	┫	┬	┴	┵
160	á	í	ó	ú	ñ	Ñ	ª	º	¿	¬	½	¼	¡	«	»	
144	É	æ	Æ	ô	ö	ò	û	ù	ÿ	Ö	Ü	¢	£	¥	Pls	f
128	Ç	ü	é	â	ä	à	ç	ê	ë	è	ï	î	ì	Ä	Å	
112	p	q	r	s	t	u	v	w	x	y	z	{		}	~	
96	`	a	b	c	d	e	f	g	h	i	j	k	l	m	n	o
80	P	Q	R	S	T	U	V	W	X	Y	Z	[	\	]	^	_
64	@	A	B	C	D	E	F	G	H	I	J	K	L	M	N	O
48	0	1	2	3	4	5	6	7	8	9	:	;	<	=	>	?
32	!	"	#	\$	%	&	'	(	)	*	+	,	-	.	/	
16																
0																
	0	1	2	3	4	5	6	7	8	9	10	11	12	13	14	15

# Code Page 850

240	-	±	=	¾	¶	§	÷	¸	°	¨	.	¹	³	²	■
224	Ó	ß	Ô	Ò	õ	Õ	µ	þ	Ɔ	Ú	Û	Ù	ý	Ý	´
208	ø	Ɔ	Ê	Ë	È	Í	Î	Ï	Ɔ	Ɔ	■	■	ì	ì	■
192	Ł	ł	Ť	ť	-	†	ã	Ā	Ĺ	Ɔ	±	Ɔ	Ɔ	=	Ɔ
176	■	■	■	■		†	Á	Â	À	©	Ɔ		Ɔ	Ɔ	Ɔ
160	á	í	ó	ú	ñ	Ñ	ª	º	¿	®	¬	½	¼	¡	»
144	É	æ	Æ	ô	ö	ò	û	ù	ÿ	Ö	Ü	ø	£	Ø	×
128	Ç	ü	é	â	ä	à	â	ç	ê	ë	è	ï	î	ì	Ä
112	p	q	r	s	t	u	v	w	x	y	z	{		}	~
96	`	a	b	c	d	e	f	g	h	i	j	k	l	m	n
80	P	Q	R	S	T	U	V	W	X	Y	Z	[	\	]	^
64	@	A	B	C	D	E	F	G	H	I	J	K	L	M	N
48	0	1	2	3	4	5	6	7	8	9	:	;	<	=	>
32	!	"	#	\$	%	&	'	(	)	*	+	,	-	.	/
16															
0															
	0	1	2	3	4	5	6	7	8	9	10	11	12	13	14

# CONFIGURING THE SYSTEM

## C

This chapter contains information useful for your System Administrator:

- ◆ Accessing the Keyboard's Main Menu.
- ◆ Operating in Script Mode.
- ◆ Configuring the Scanner.

## Accessing the Keyboard's Main Menu

---

The Keyboard's Main Menu allows you to load scripts, setup communication parameters, and select a display language for the Keyboard's Main Menu. Changing a display language does not change the language of any script messages.

To access the Keyboard's Main Menu, press **X** on the keyboard within the first two seconds when the printer/keyboard are turned on to see the Keyboard's Main Menu.

## Operating in Script Mode

---

This manual does not cover any specific information about what may be in your script, because every script is different. Your script is written based on jobs you need to perform. Your script automatically runs when you turn on the printer and keyboard. The prompts you see and what you do are controlled by the script.

## About the Scanner

---

A scanner is optional for the keyboard. For more information about the scanner or other peripheral devices, refer to their *User Manuals*.

Use this section to

- ◆ operate the scanner.
- ◆ troubleshoot the scanner.
- ◆ clean the scanner's window.
- ◆ configure the scanner. Your ADK script should already be written to enable and configure the scanner for you.

The scanner must be connected before you can use it. See "[Connecting the Scanner's Cables](#)" in Chapter 1 for more information.

## Operating the Scanner

### CAUTION

Do not stare into the beam.

---

To scan a bar code:

1. Point the scanner at a slight angle to, and approximately four to eight inches from the bar code symbol.
2. Press the button on the scanner. When the scanner is in the stand, it automatically scans any bar codes held in front of the scanner's window. Make sure you do not scan data twice or accidentally scan the wrong data.

### Troubleshooting the Scanner

If the bar code does not scan:

- ◆ Change the scanner's angle slightly and try again.
- ◆ Move the scanner four to eight inches away from the bar code. Adjust this distance as needed to find the correct distance.
- ◆ Try scanning another bar code that you have scanned successfully. If that scan is successful, the scanning problem may be with the bar code.
- ◆ Move to a more dimly lit area.
- ◆ Ensure there are no voids (streaks) in the bar code symbol.
- ◆ Clean the scanner window. See "[Cleaning](#)" for more information.
- ◆ If the scanner stays in the same place without scanning anything for awhile, the scanner may appear to "time out." If this happens move the scanner slightly and then towards the bar code you want to scan. The scanner should scan the bar code. Make sure you do not scan data twice or accidentally scan the wrong data.
- ◆ Before you call Service, print a set of test labels. The test labels contain information to help Service diagnose mechanical and setup problems. To print a set of test labels, press **F1** when you see "Print Mode Ready."



## Cleaning

Clean the scanner window whenever it appears to be dirty or smeared.

To clean it:

1. Moisten a soft cloth with water.
2. Wipe the window until it is completely clean.

## Configuring the Scanner

---

The scanner may already be configured to work with your ADK script.

If not, use these bar codes to configure the scanner:

- ◆ Reset to default values.
- ◆ Set the communication port to match the keyboard's settings.
- ◆ Set the minimum bar code width (if necessary).

For additional bar codes to program your scanner, refer to your scanner's *Installation and User's Guide* for more information.

### Reset to Default Values

To reset the scanner to default settings, scan this bar code:



**Reset to defaults**

## Set the Communications Port Defaults

To set the communications port to the same defaults as the keyboard, scan the following series of bar codes, one at a time, from top to bottom.



Enter/exit config. mode



9600 baud



8 data bits



No parity



2 stop bits



Enter/exit config. mode

You can also set the communication values by using the Keyboard's Main Menu. The keyboard defaults are 9600 Baud, 8-bit Word Length, 2 Stop Bits, No Parity, and No Flow Control.

1. Press **X** on the keyboard within the first two seconds when the printer/keyboard are turned on to see the Keyboard's Main Menu.
2. Select Setup. Press  $\leftarrow$  or  $\rightarrow$  until you see

```
  SETUP
←  COM2 (Scanner)  →
```

3. Press **Enter**. You see a list of communication options to change (Baud Rate, Word Length, Stop Bits, Parity, and Flow Control).

```
  COM2 (Scanner)
      Baud Rate  →
```

4. Press **Enter** to change the Baud Rate. Use  $\leftarrow$  or  $\rightarrow$  to scroll through the choices. Press **Enter** when the Baud Rate you need appears. Continue through the list for the other communication settings and make changes if necessary.

## Set the Minimum Bar Code Width

To scan single-digit bar codes, scan the following series of bar codes, one at a time, from top to bottom.



Enter/exit config. mode



Min. symbol length



0



0



1



Enter/exit config. mode

# INDEX

## A

ANSI  
symbol set ..... B-1

## B

bar code 128 ..... 4-1  
batch  
entering ..... 3-2

## C

code page  
DOS 437 ..... B-1  
DOS 850 ..... B-1  
code pages ..... B-1  
correct font  
for entered data ..... B-1

## D

data entry ..... 4-1  
data entry mode ..... 3-2

## F

fixed data ..... 4-1  
font selection  
matches symbol set ..... B-1  
function  
keys ..... 1-9  
function codes ..... 4-1

## K

keyboard  
operating temperature ..... A-1  
keyboard layout ..... 1-9

## M

mode  
data entry ..... 3-2  
offline ..... 4-1

## O

offline mode ..... 4-1  
operating limits  
keyboard ..... A-1

## P

print  
offline mode ..... 4-1

## S

symbol set ..... B-1  
ANSI ..... B-1  
matches font selection .... B-1







028028

Avery Dennison Printer Systems Division  
170 Monarch Lane  
Miamisburg, OH 45342

**1-800-543-6650 (In the U.S.A.)**  
**1-800-387-4740 (In Canada)**  
**[www.monarch.averydennison.com](http://www.monarch.averydennison.com)**

