

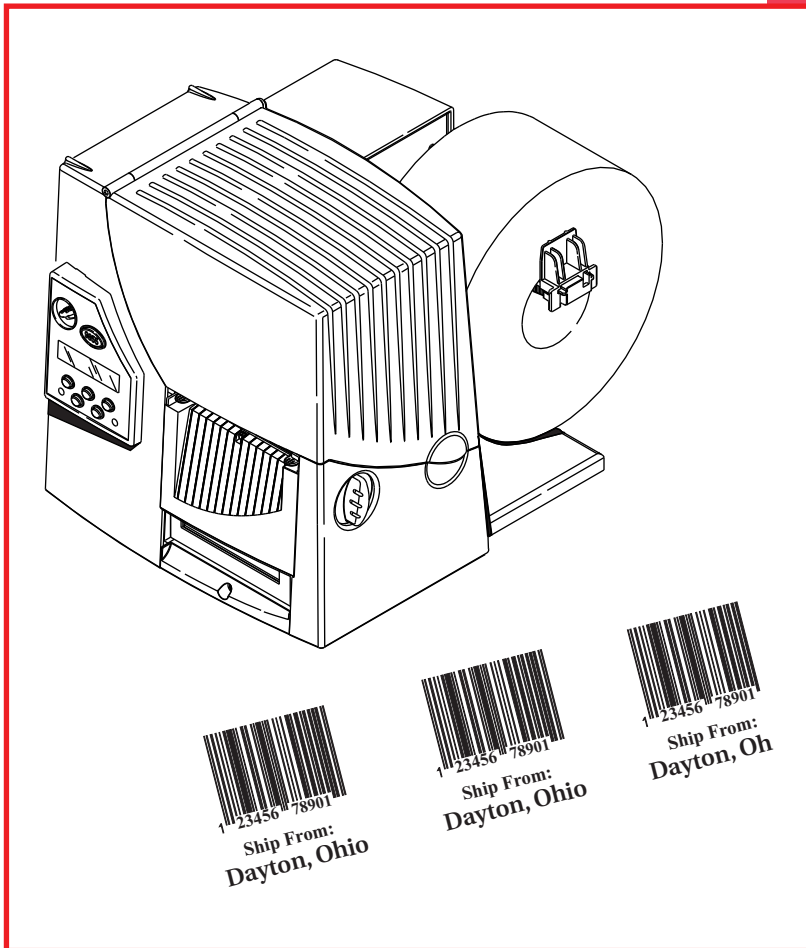

Operator's Handbook

Monarch® 9855®
Printer



Each product and program carries a respective written warranty, the only warranty on which the customer can rely. Avery Dennison Corp. reserves the right to make changes in the product, the programs, and their availability at any time and without notice. Although Avery Dennison Corp. has made every effort to provide complete and accurate information in this manual, Avery Dennison Corp. shall not be liable for any omissions or inaccuracies. Any update will be incorporated in a later edition of this manual.

©2003 Avery Dennison Corp. All rights reserved. No part of this publication may be reproduced, transmitted, stored in a retrieval system, or translated into any language in any form by any means, without the prior written permission of Avery Dennison Corp.

WARNING

This equipment has been tested and found to comply with the limits for a Class A digital device, pursuant to Part 15 of the FCC Rules. These limits are designed to provide reasonable protection against harmful interference when the equipment is operated in a commercial environment. This equipment generates, uses, and can radiate radio frequency energy and, if not installed and used in accordance with the instruction manual, may cause harmful interference to radio communications. Operation of this equipment in a residential area is likely to cause harmful interference in which case the user will be required to correct the interference at his own expense.

CANADIAN D.O.C. WARNING

This digital apparatus does not exceed the Class A limits for radio noise emissions from digital apparatus set out in the Radio Interference Regulations of the Canadian Department of Communications.

Le présent appareil numérique n'émet pas de bruits radioélectriques dépassant les limites applicables aux appareils numériques de la classe A prescrites dans le Règlement sur le brouillage radioélectrique édicté par le ministère des Communications du Canada.

Trademarks

Monarch®, 7411™, 9825®, 9850®, 9855®, and 9860™ are trademarks of Avery Dennison Retail Information Services LLC.

Avery Dennison® is a trademark of Avery Dennison Corp.

HP Jet Admin and HP Web Jet Admin are trademarks of Hewlett-Packard, Inc.

Hewlett-Packard is a registered trademark of Hewlett-Packard, Inc.

Centronics is a registered trademark of Centronics Data Computer Corporation.

TrueType is a registered trademark of Apple Computer, Inc.

Other products are trademarks or registered trademarks of their respective countries and are hereby acknowledged.

Avery Dennison Printer Systems Division
170 Monarch Lane
Miamisburg, OH 45342



TABLE OF CONTENTS

GETTING STARTED	1-1
Audience.....	1-2
Using this Manual.....	1-2
Unpacking the Printer.....	1-3
Shipping the Printer.....	1-3
9445™ Printer Online Emulation.....	1-4
Ordering Programmer's Manuals.....	1-4
About Monarch® MPCL™ Toolbox Utilities.....	1-4
Connecting the Power Cable.....	1-4
Establishing Communications.....	1-5
Connecting the Communication Cable.....	1-5
Using the Control Panel.....	1-6
Printer Status Lights.....	1-6
Button Functions.....	1-6
Display.....	1-7
Selecting a Function.....	1-7
Exiting an Option.....	1-8
LOADING SUPPLIES	2-1
Loading Labels or Tags.....	2-2
Loading Labels for the Optional Peel Mode.....	2-7
Using the Optional Tear Bar.....	2-9
Using String Tag Supply.....	2-10
String Tag Considerations.....	2-10
Adjusting the Wide/Narrow Knobs.....	2-12

LOADING RIBBON	3-1
Loading Ribbon	3-2
Using a High Energy Ribbon.....	3-4
High Energy Ribbon Limitations.....	3-5
SETTING SUPPLY OPTIONS	4-1
Setting the Supply Type	4-3
Setting the Ribbon	4-4
Setting the Speed	4-5
Setting the Feed Mode	4-6
Setting the Backfeed.....	4-7
Changing the Position Settings	4-8
Setting the Print Position	4-8
Setting the Supply Position	4-10
Setting the Margin Position	4-11
Setting the Cut Position	4-12
Setting the Dispense Position.....	4-13
Setting the Backfeed Distance.....	4-14
Using Batch Separators	4-15
Using Skip Index	4-16
Setting the Knife Control	4-17
Setting the Error Action.....	4-18
Setting the Print Contrast.....	4-20
Enabling the Verifier	4-22

SETTING COMMUNICATIONS	5-1
Setting the Baud Rate	5-2
Setting the Word Length.....	5-2
Setting the Stop Bits.....	5-3
Setting the Parity.....	5-3
Setting the Flow Control.....	5-4
Resetting to Default Values	5-4
Using Parallel Communications.....	5-5
Setting the Port.....	5-5
Setting the Mode.....	5-6
SETTING DEFAULTS	6-1
Setting the Monetary Sign	6-3
Setting the Secondary Sign	6-4
Setting the Number of Decimal Places.....	6-5
Setting the Slashed Zero Appearance	6-5
Setting the Power-Up Mode	6-6
Changing the Prompt Set	6-6
Setting the Numeric Format	6-7
Using Flash Storage	6-8
Disabling Image Errors.....	6-9
Ignoring Configuration Packets.....	6-10
Using Error Retry Mode.....	6-11
Adjusting the Image Length	6-12
Using Flash Memory	6-14
Formatting Flash Memory.....	6-14
Checking Available Flash Memory	6-15
Packing Flash Memory.....	6-16

Memory Guidelines	6-17
Setting Batch Options	6-18
Setting Up the Network Printer	6-18
Setting Up the RFID Printer	6-18
USING SCRIPTS	7-1
Initial Script Startup Procedures	7-2
Viewing Script Information.....	7-2
Downloading a Script	7-3
Enabling a Script	7-4
Deleting a Script.....	7-5
Enabling Status Polling	7-6
Using Immediate Commands.....	7-7
PRINTING	8-1
Printing.....	8-1
On-Demand Mode Printing.....	8-2
Printing an Error Label	8-2
Pausing a Batch	8-3
Restarting a Batch	8-3
Canceling a Paused Batch.....	8-4
Repeating a Batch	8-6
Offline Printing	8-6
Special Printing Considerations	8-7
Printing TrueType® Fonts	8-8
Licensing Your Fonts	8-8
CARE & MAINTENANCE	9-1
Clearing Label Jams	9-1
Cleaning	9-1
Replacing the Printhead	9-5

DIAGNOSTICS & TROUBLESHOOTING	10-1
Factory Set Password	10-1
Checking the Software Version	10-1
Printing a Test Label.....	10-2
Checking Supply Quality	10-3
Using Password Protection.....	10-4
Enabling the Password (System Administrators only)	10-4
Service Diagnostics	10-5
Troubleshooting.....	10-6
Error Messages	10-7
Common Errors	10-8
SPECIFICATIONS	A-1
Printer	A-1
Tag Cut Dimensions	A-2
Supplies	A-3
String Tag Supplies	A-4
Ribbon Specification	A-5
About Ribbons	A-5
Cable Pinouts.....	A-6
ACCESSORIES & OPTIONS	B-1
Accessories	B-1
Packaging Materials	B-2
Factory-Installed Options	B-2
Ethernet Information.....	B-3
RF Information	B-3
MENU STRUCTURE	C-1
GLOSSARY	G-1
INDEX	1

GETTING STARTED

1

The Monarch® 9855® printer lets you print text, graphics, and bar codes on thermal transfer (ribbon) and thermal direct labels or tags. The 9855 printer prints labels continuously (in one strip) or on-demand (one label at a time).

You can print on aperture, die cut, black mark, or continuous (non-indexed) supplies. Continuous supply must be used in continuous mode. See "Supply Type" in Chapter 4 for more information about the supply types.

This chapter includes information about

- ◆ unpacking the printer
- ◆ connecting the power cord
- ◆ connecting the communication cable
- ◆ using the printer's control panel.

Several chapters of this manual have one or more charts showing the printer's menu structure. For example:

Main Menu

Cancel All	Print Mode	Batch Entry	Repeat Batch	Batch Options	Setup	Scripts	Diagnostics
Supply	Contrast	Defaults	Network	Port Settings	Flash Memory	Verifier	RFID

The black boxes show where you are; the bordered boxes show how you got there.

Refer to the *MonarchNet2™ Operating Instructions* for information about the Network menu.

Refer to the *RFID Application Notes* for information about the RFID menu.

Audience

The *Operator's Handbook* is for the person who prints and applies labels.

Using this Manual

Following is a summary of the contents of this manual.

Chapter		Contents
1	Getting Started	Contains information about connecting the power cable and using the control panel.
2	Loading Supplies	Describes how to load a roll of supply, fan-fold supply, and tag supply.
3	Loading Ribbon	Describes how to load a roll of ribbon and lists high-energy ribbon information.
4	Setting Supply Options	Using the Supply menu to set the various supply options (supply, ribbon, feed mode, etc.).
5	Setting Communication Values	Using the Port Settings menu to set the serial and parallel communication values (baud rate, parity, etc.).
6	Setting Defaults	Using the Defaults menu to set the monetary sign, number of decimal places, prompt set, etc.
7	Using Scripts	Using the Scripts menu to load a script, enable a script, delete a script, etc.
8	Printing	Explains how to print labels and use the Pause menu.
9	Care & Maintenance	Describes how to clear a label jam, clean the printer, and replace the printhead.
10	Diagnostics & Troubleshooting	Describes how to print a test label and lists common problems and their solutions.
A	Specifications	Contains printer and supply specifications.
B	Accessories & Options	Contains printer accessories and optional equipment.
C	Menu Structure	Contains a chart of the printer's menu options.

Unpacking the Printer

After you unpack the printer, you should have the printer, a power cord, and a ribbon take-up core (may already be on take-up reel). Keep the box and packaging material in case the printer ever needs repair.

Shipping the Printer

If you need to ship the printer to a different location:

1. Remove the ribbon roll, if one is loaded.
2. Remove the supply roll, if one is loaded.
3. Close the printhead by pressing down on the thumb well until you hear it click into place.

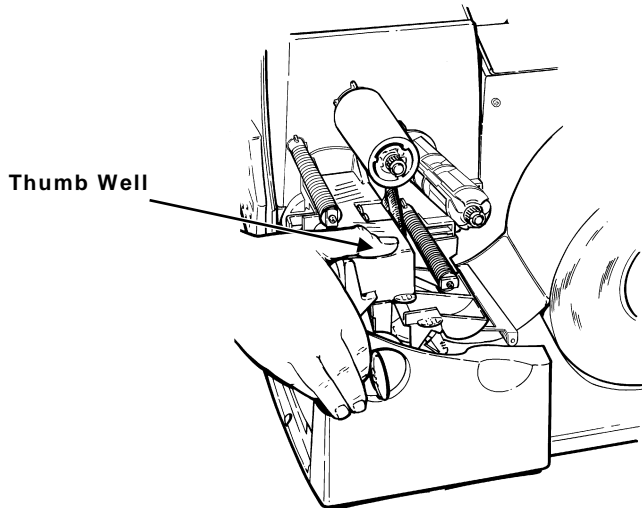

4. Place the printer in the original box and secure with packaging material. **Make sure the printer is adequately packed to avoid damage during shipment.** See Appendix B, "Accessories & Options" for the packaging materials part numbers.

9445™ Printer Online Emulation

The 9855 printer using 203 dpi (dots per inch) printing supports 94x5 emulation. You can send 94x5 data streams to this printer.

Refer to your 9445 *Programmer's Manual* for information about 94x5 data streams.

Ordering Programmer's Manuals

The *Packet Reference Manual*, which describes how to create format and batch packets for printing labels, how to configure the printer online, how to diagnose printer error messages, and how to perform other advanced techniques can be downloaded from our Web site (www.monarch.averydennison.com). You can print this manual or order a hard-copy version (part number TC9800PM).

About Monarch® MPCL™ Toolbox Utilities

The Monarch® MPCL™ Toolbox utilities are available on our Web site and are free to download. This group of development utilities helps you configure the printer, customize fonts, and download files. Monarch MPCL Toolbox utilities are not label production software. Call Customer Service for information about label production software.

Connecting the Power Cable

The power supply automatically switches between 115V or 230V. No operator settings are required.

1. Plug the power cable into the socket. Plug the other end of the cable into a grounded electrical outlet.

Note: Only use a certified power cable with proper voltage for the country of installation.

2. Turn on the printer. Press (I) to turn on and (O) to turn off the printer.

Establishing Communications

Before the printer can accept print jobs from the host, you must:

- ◆ Connect the communication cable to the printer and to the host.
- ◆ Set the communication values on the printer to match those at the host. (Only required if you are using the serial port.)
- ◆ Make sure the printer is off before connecting the cable to the communication port.

Ask your System Administrator which method to use to communicate with the host:

Serial Communication

9 to 25-pin cable

(Part #119806)

25 to 25-pin cable

(Part #126826)

Parallel Communication

IEEE-1284 or

Centronics® mode cable (Part #126805)

Connecting the Communication Cable

Connect the communication cable into the appropriate port. Secure the cable with the connecting screws (serial) or spring clips (parallel).

If you are communicating with the host through the serial port, make sure the printer's communication values match those at the host. The factory default values are 9600 Baud, 8 bit data frame, 1 stop bit, no parity, and DTR flow control.

The printer also has a USB (Universal Serial Bus) Version 1.1 communication port. Drivers are available on our Web site for a variety of operating systems.

Note: The printer supports a baud rate up to 115200. Make sure your host is capable of communicating at the speed you select for the printer.

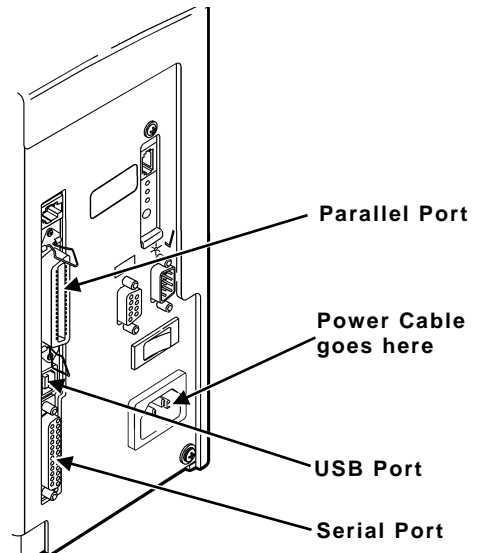

Using the Control Panel

The control panel has a two-line LCD display, 2 status lights, and five buttons. The control panel displays error codes/messages, and allows you to setup/configure the printer.

Printer Status Lights

Power:

The printer shows a steady green light when it is on.

The Power light blinks when the battery needs to be recharged (only on battery-powered/cart models).

Fault:

The printer shows a blinking amber light when there is a printer error.

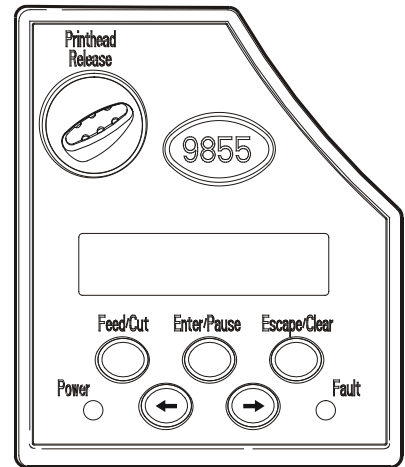

Button Functions

Feed/Cut:

- ◆ Prints a label in the on-demand mode.
- ◆ When the printer is online, feeds a blank label if there is no print job.
- ◆ Prints a label with error information that is useful to your System Administrator if an error is displayed.
- ◆ When the printer is online, cuts the supply when pressed and held for two seconds if a knife is installed.
- ◆ When the printer is offline, changes the displayed value by one or 10.

Enter/Pause: When the printer is online, pauses the current print job or resumes a paused print job. When the printer is offline, selects the displayed menu item.

Escape/Clear:

- ◆ When an error is present, clears the error.
- ◆ When a job (batch) is printing, cancels the print job (batch). See "Canceling a Paused Batch" in Chapter 8 for more information.
- ◆ When the printer is online (without errors), enters the offline menu mode.
- ◆ When the printer is in the offline menu mode, returns the display to the next higher menu.



When the printer is in the offline menu mode, displays the previous menu item.



When the printer is in the offline menu mode, displays the next menu item.



In online mode, prints a test label when you press the buttons at the same time. Hold for one second and release.

Display

The display shows a three-digit error code and brief message to identify any problem the printer may have. For a description of the problem, look up the error code in Chapter 10, "Diagnostics & Troubleshooting."

Selecting a Function

The Main menu has several functions (operating modes). These functions are shown in the chart below. See Appendix C, "Menu Structure" for a complete list of menu options.

Main Menu

Cancel All	Print Mode	Batch Entry	Repeat Batch	Batch Options	Setup	Scripts	Diagnostics
Supply	Contrast	Defaults	Network	Port Settings	Flash Memory	Verifier	RFID

Note: If the printer displays PRINT MODE Ready when you turn it on, press Escape/Clear to display the Main menu.

To display menu options, press ← or →.

1. When the screen displays a right arrow, press → to display more options.



2. When the screen displays a left arrow, press ← to display more options.



3. When the screen displays a left and a right arrow, press either ← or → to display more options.

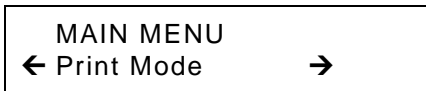

4. When you see the menu option you want, press **Enter/Pause** to select it.

The Main Menu controls the printer's setup and operation. Through the Setup Menu, you can select a sub-menu for the supply, contrast, default, or port settings. Each of those sub-menus have several options, such as ribbon, speed, monetary symbols, and baud rate.

Exiting an Option

To exit an option, press **Escape/Clear** once.

LOADING SUPPLIES

2

This chapter describes how to load:

- ◆ a roll of supply
- ◆ fan-fold supply
- ◆ a roll of tag supply.

There are three types of supplies:

Thermal Direct	heat activated supplies that do not use a ribbon for printing.
Thermal Transfer	standard supplies that require a ribbon for printing.
High Energy	scratch, chemical, and temperature resistant supplies that require an elevated heat setting for resin ribbon applications. See "Using a High Energy Ribbon" in Chapter 3 for more information.

If you are using thermal direct supplies, do not load a ribbon.

If you switch from black mark to die cut supplies, make sure the printer's supply type is set correctly. See "Supply Type" in Chapter 4 for more information. Your System Administrator can also send the supply setup packet to change the supply type. Refer to the optional *Packet Reference Manual* for more information about sending the supply setup packet.

Loading Labels or Tags

Make sure the printer is configured for the correct supply type.

1. Open the cover.

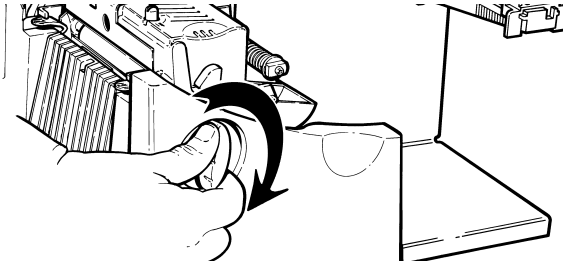

2. Unlock the printhead by turning the retaining latch.
3. Lift printhead assembly using the printhead tab until the assembly locks into place.

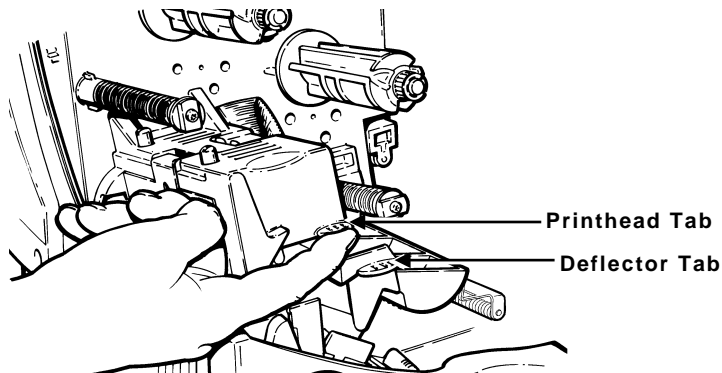

4. Place the roll of supply on the supply holder. For labels, the supply unrolls from the top or the bottom. For tags, make sure the supply unrolls from the bottom, because tag rolls are wound face in.

Note: Do not pick up the printer by the supply holder.

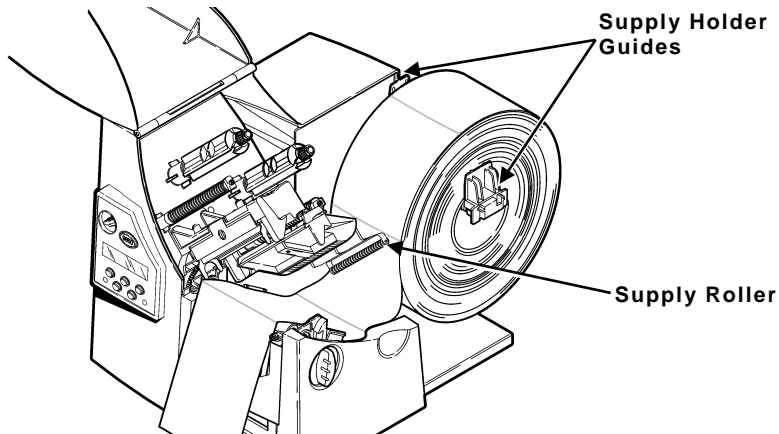

5. Adjust the supply holder guides so the sides barely touch the roll. Make sure the supply roll turns freely.

If you are using fan-fold supplies, place the supply stack behind the printer, label side facing up.

6. Push down on the supply lever to unlock the supply guides.
7. Lay the label strip across the supply guide so that a few inches extend past the front of the printer. Tuck the supply under the nibs and in between the die cut sensor. **Do not feed supply between the supply roller and deflector.**

For fan-fold supplies, lay the label strip over the supply holder and across the supply guide so that a few inches extend past the front of the printer. Tuck the supply under the nibs and in between the die cut sensor.

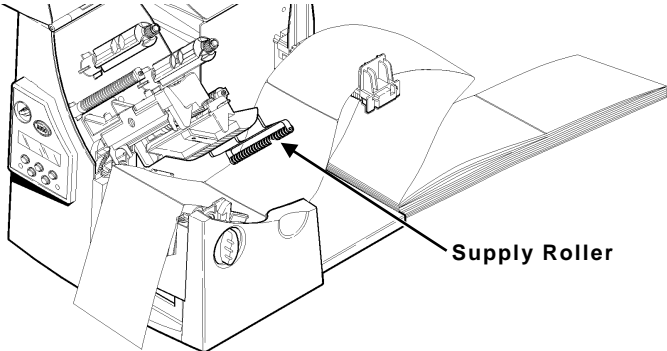
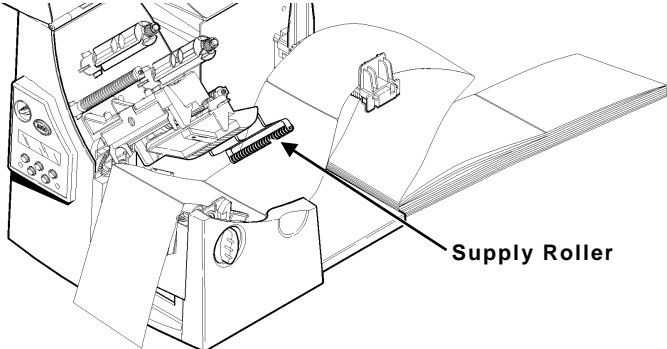

For tag supplies using the optional knife, feed the supply through the knife. Make sure at least 0.5 inches of supply is past the knife.

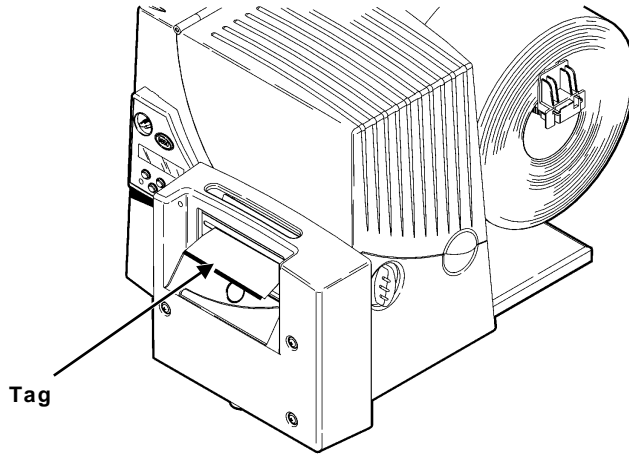

8. Adjust the supply guides so they touch the supply. Push up on the supply lever to lock the supply guides into place.

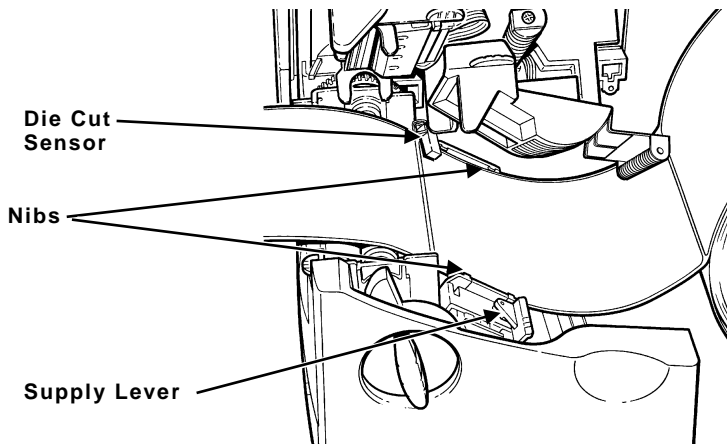

9. Hold the printhead assembly by the printhead tab while pressing down on the printhead release.

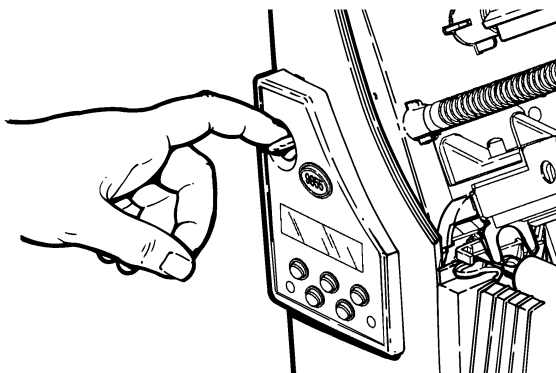

10. Close the printhead by pressing down on the thumb well until you hear it click into place.

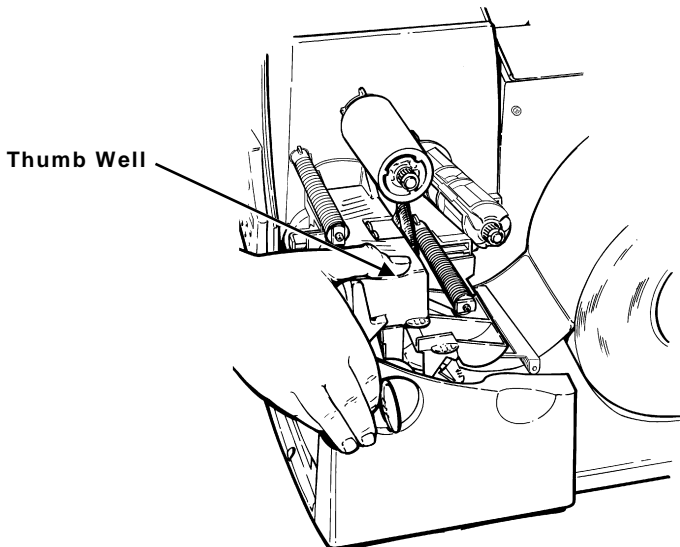

11. Close the cover.

12. Press **Feed/Cut** to position the supply under the printhead.

You may need to adjust the wide/narrow knobs depending on the width of your supply. See "Adjusting the Wide/Narrow Knobs" for more information.

Note: If the printer will be unused for extended periods of time, we recommend leaving the printhead unlatched.

Loading Labels for the Optional Peel Mode

Peel mode is an option that must be purchased separately. In peel mode, the printer separates the backing paper from the label. The next label is not printed until the completed one is removed from the printer. Make sure the printer is configured for on-demand mode and the correct supply type.

The minimum feed length is 1.5 inches for peel mode. We recommend using 0.5-inch gap supplies in peel mode when backfeed is disabled. Hold the leading edge of peeled labels when printing on stock longer than six inches. You must use non-perforated supplies for peel mode. Follow the steps for loading supplies from the previous section. Then, follow these steps after you close the printhead.

1. Remove the labels from the first 10 inches of the backing paper.
2. Press down on the exit cover tabs to open the exit cover on the front of the printer.

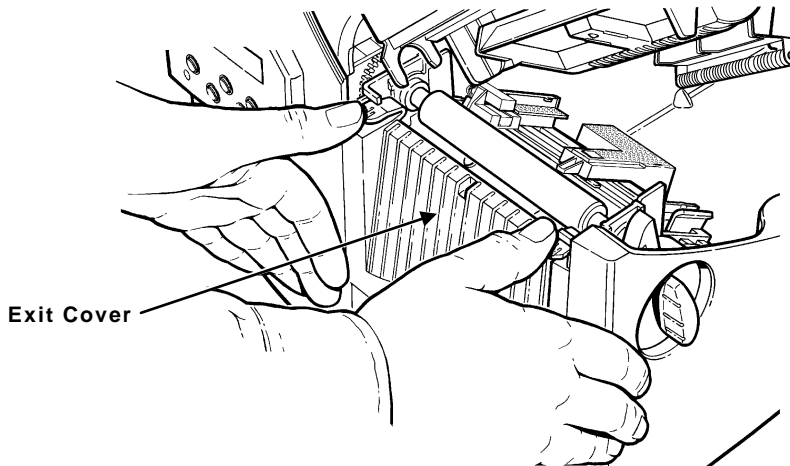

3. Feed the backing paper over the peel bar.

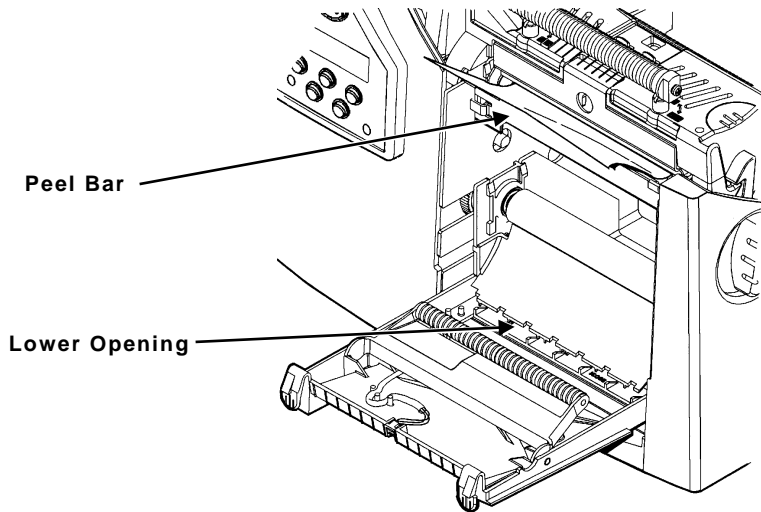

4. Feed the backing paper through the lower opening of the exit cover. Close the exit cover. Pull down on the backing paper to remove any slack.

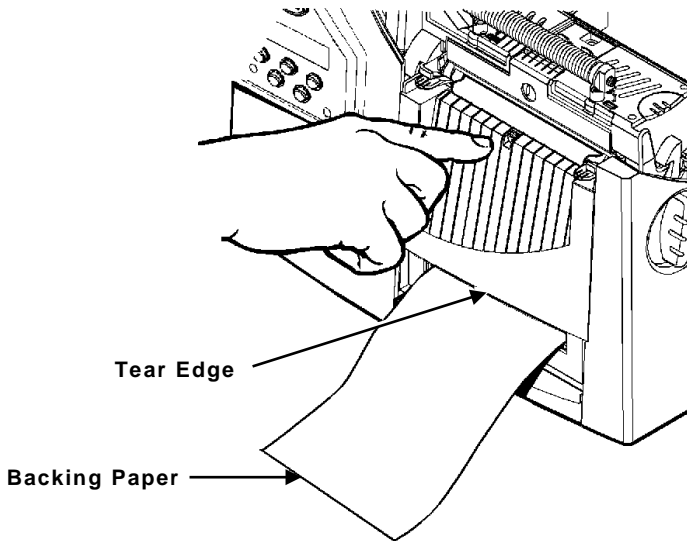

When removing the backing paper, pull up across the saw-toothed tear edge. Make sure the backing paper tears at the edge.

5. Close the printer's cover.
6. Press **Feed/Cut** to position the supply under the printhead.

Using the Optional Tear Bar

Note the following change to loading labels if you have purchased the optional tear bar. Tear labels against the tear bar. You cannot tear tags with the tear bar.

Slide the supply between the tear bar and peel bar. It may be easier if you cut or fold one corner of the supply first.

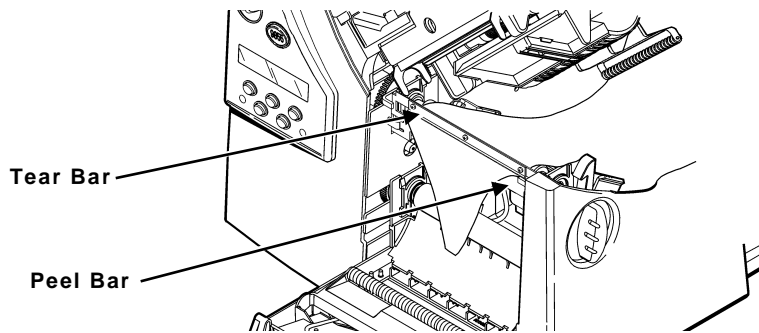

Note: Do not tear both label and backing paper at the same time.

- ◆ Tear labels against the tear bar.
- ◆ Tear backing paper against the tear edge.

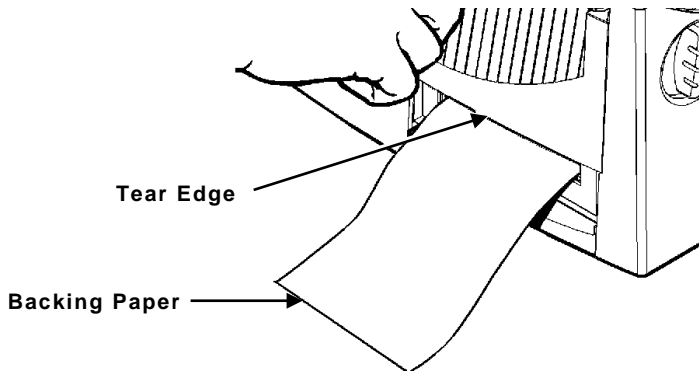

Using String Tag Supply

String tags are used in a variety of applications, such as jewelry tags and item marking.

String Tag Considerations

- ◆ Thermal direct printing, fan-fold supplies, and the knife are not supported with string tags.
- ◆ The maximum print speed with string tags is 6.0 inches per second (ips).
- ◆ A non-print zone of 0.250 inches (6.4 mm) exists on the string side of the tag.
- ◆ Use the wide setting for string tags.

Make sure the printer is configured for the correct supply type.

1. Open the cover.
2. Unlock the printhead by turning the retaining latch.
3. Lift printhead assembly using the printhead tab until the assembly locks into place.
4. Shake the roll of string tags down to untangle the roll.

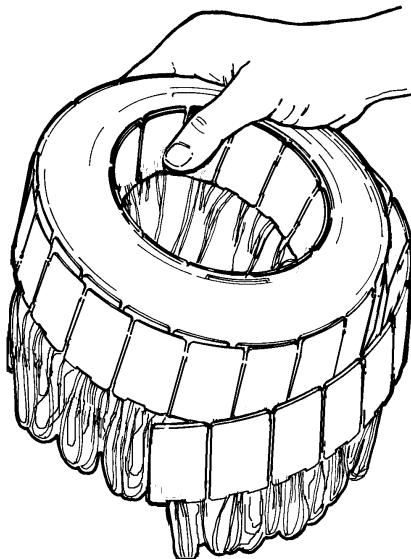

5. Place the roll of supply on the supply holder with the strings facing out.
6. Adjust the supply holder guides so the sides barely touch the roll. Make sure the supply roll turns freely.

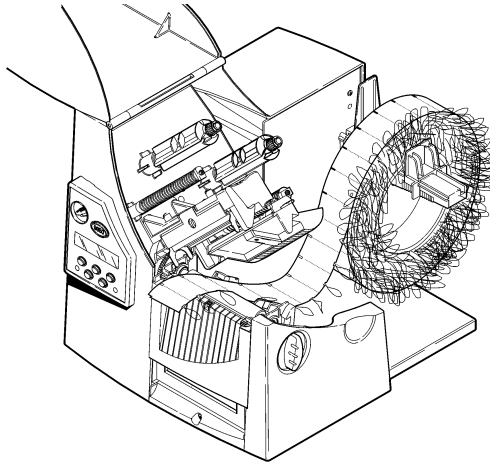

7. Push down on the supply lever to unlock the supply guides. The supply guides have been angled slightly for string tag supplies.
8. Lay the supply across the supply guide so that a few inches extend past the front of the printer. Tuck the supply under the nibs and in between the die cut sensor.
9. Adjust the supply guides so they touch the supply. Push up on the supply lever to lock the supply guides into place.

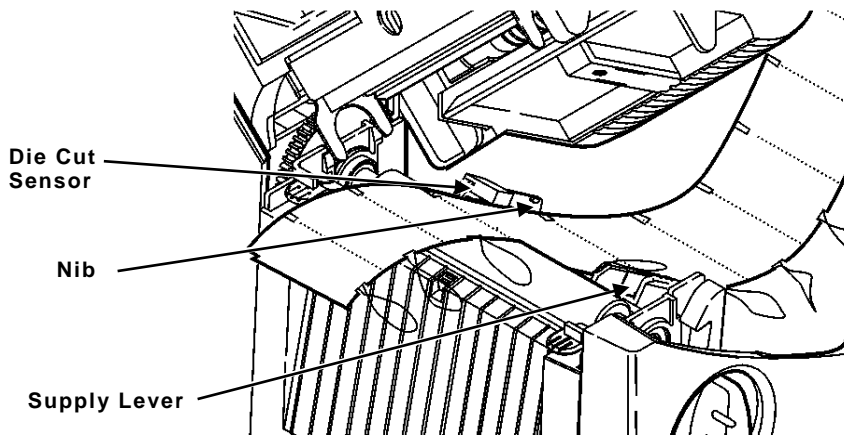

10. Hold the printhead assembly by the printhead tab while pressing down on the printhead release.
11. Close the printhead by pressing down on the thumb well until you hear it click into place.
12. Close the cover.
13. Press **Feed/Cut** to position the supply under the printhead.
If the printer will be unused for extended periods of time, we recommend leaving the printhead unlatched.

Adjusting the Wide/Narrow Knobs

You may need to adjust the two wide/narrow knobs according to the width of your supply. For supply that is more than two inches, adjust the knobs to the wide setting. For supply that is two inches or less, adjust the knobs to the narrow setting. For string tag supply, use the wide setting (knobs are down).

You must adjust both of the knobs to the same position.

If you experience ribbon smudging in cold, dry environments, adjust the wide/narrow knobs to the wide setting.

For wide supplies, push down and turn the wide/narrow knobs clockwise with a screwdriver.

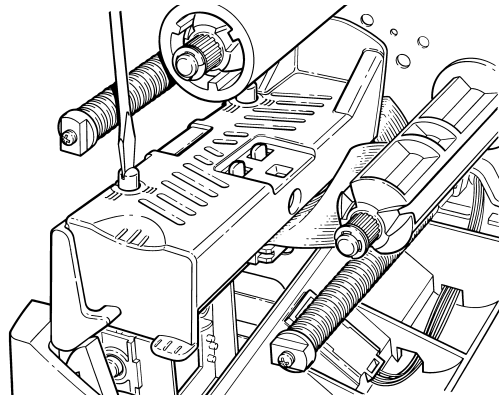

For narrow supplies, turn the wide/narrow knobs counter-clockwise with a screwdriver until it pops back up.

Note: The adjustment is shown in the wide position.

LOADING RIBBON

This chapter describes how to load a ribbon roll.

There are different ribbon requirements for the three types of supplies:

Thermal Direct Supplies do not use a ribbon for printing.

Thermal Transfer Supplies require a ribbon for printing.

High Energy Supplies require a ribbon able to withstand high temperatures.

If you are using thermal direct supplies, do not load a ribbon.

If you are using high energy supply, be sure to use a high energy ribbon. See "Using a High Energy Ribbon" for more information. To set ribbon options at the printer, see "Ribbon" in Chapter 4.

Loading Ribbon

Make sure the printer is configured to use a ribbon.

To load ribbon:

1. Open the cover.
2. Unlock the printhead by turning the retaining latch.
3. Lift printhead assembly using the printhead tab until the assembly locks into place.

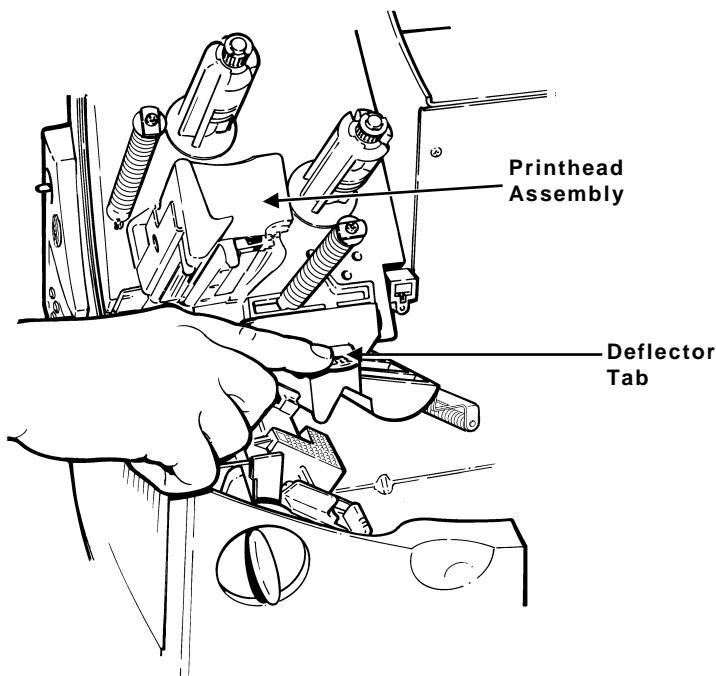

4. Push the deflector tab down.
5. Slide the extra ribbon core on the take-up reel as far as it will go with the "This End Out" writing facing out. Use your empty ribbon core as the take-up core. The take-up core only fits on the take-up reel one way. (An extra take-up core is available by ordering part number 117961.)

6. Remove the new ribbon from the package as shown. Do not wrinkle or crush the new ribbon.

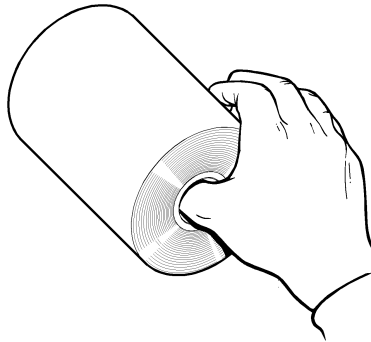

7. Slide the ribbon onto the back reel as far as it will go. The ribbon roll only fits on the reel one way. Carefully unwind a few inches of ribbon from the bottom of the roll.

Note: Make sure the “Monarch This End Out” writing is facing out. The ribbon only fits on the reel one way.

8. Carefully feed the ribbon under both ribbon rollers and printhead as shown.
9. Align the ribbon and make sure it is straight and centered throughout the path.
10. Tape the ribbon to the take-up core. ***Do not tape the ribbon to the take-up reel.***
11. Rotate the take-up core until the leader is past the printhead.

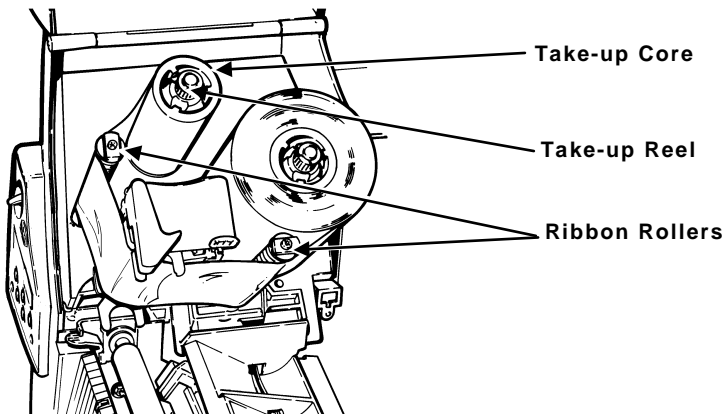

12. Remove any slack in the ribbon by turning the take-up reel clockwise.
13. Hold the printhead assembly by the printhead tab while pressing down on the printhead release.
14. Close the printhead by pressing down on the thumb well until you hear it click into place. Close the cover.

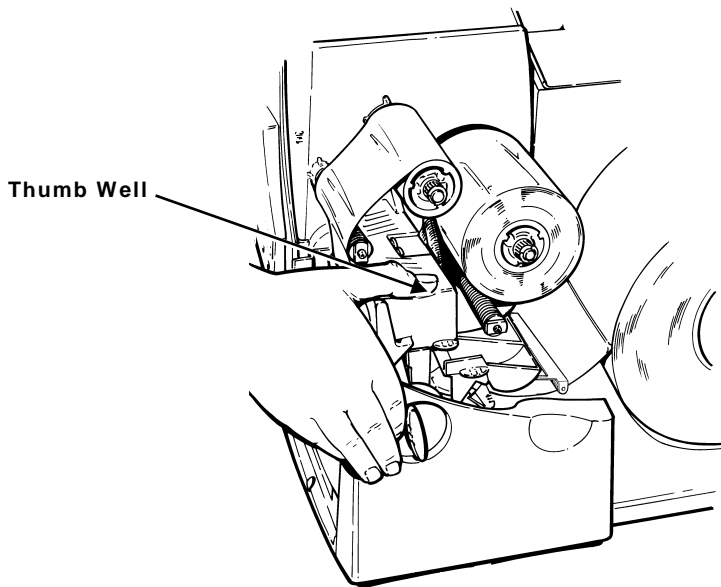

Using a High Energy Ribbon

High energy ribbon is an option for this printer. It enables you to print on high energy (TUFF-MARK®) supplies.

When you select high energy ribbon for the printer setting, you are setting the printer to a higher printing temperature. Select this setting only after you have loaded a high energy ribbon and supply or it may damage your printhead. See "Ribbon" in Chapter 4 for more information.

High Energy Ribbon Limitations

When using the high energy ribbon option:

- ◆ Use a print speed of 2.5IPS (inches per second).
- ◆ Printhead warranty is reduced to 100,000 inches.
- ◆ Serial bar codes cannot be printed.
- ◆ Do not use peel mode.
- ◆ No more than 20% of the supply should have print (black coverage).

CAUTION: The high energy ribbon may break or stick to the supply when more than 20% of the supply contains print.

- ◆ Only white high energy supply should be used for bar code printing.
- ◆ Reverse fonts cannot be used.
- ◆ A non-printing area of at least .1 inch (2.54 mm) must exist on the left and right edge of the ribbon.
- ◆ Do not print horizontal lines or bars.
- ◆ Graphics are limited.

SETTING SUPPLY OPTIONS

4

This chapter explains how to select the supply type, ribbon, speed, feed mode, backfeed, print position, supply position, margin position, cut position, dispense position, backfeed distance, separators, skip index mode, set knife control, and set error action.

This chapter also explains how to adjust the print contrast and enable the verifier.

Main Menu

Cancel All	Print Mode	Batch Entry	Repeat Batch	Batch Options	Setup	Scripts	Diagnostics		
Supply	Contrast	Defaults	Network	Port Settings	Flash Memory	Verifier	RFID		
Supply Type	Ribbon	Speed	Feed Mode	Backfeed	Positioning	Separators	Skip Index	Knife Ctrl	Error Action

Your System Administrator may limit access to this menu to prevent supply, network, script, or communication settings from being changed. If password protection is turned on, you see

Enter Password -----

when you try to access the setup menu. Get the password from your System Administrator to continue.

The options are listed in the table below.

Option	Choices	Default
Supply Type	Aperture/Die Cut/Black Mark/Continuous	Die Cut
Ribbon	No/Yes/High Energy	Yes
Speed	2.5/4.0/6.0/8.0/10.0/12.0/Default	Default
Feed Mode	Continuous/On-Demand	Continuous
Backfeed	Off/On/Extended	Off
Print Position	-450 to 450	0
Supply Position	-300 to 300	0
Margin Position	-99 to 99	0
Cut Position	-300 to 300	0
Dispense Position	50 to 200	65
Backfeed Distance	10 to 200	65
Separators	No/Yes/Long	No
Skip Index	No/Yes	No
Knife Control	-20 to 20	0
Error Action	Normal Overstrike/Continue x1 Overstrike/Continue x2 Overstrike/Continue x3 Overstrike/Continue x4 Overstrike/Continue x5	Normal
Contrast	-699 to 699	0

To exit an option without changing the setting, press **Escape/Clear**.

Setting the Supply Type

You can print on aperture, black mark, die cut, or continuous supplies. You have to tell the printer which supplies you are using.

Note: If you are using edge aperture supplies, use the die cut setting. If you are using center aperture supplies, use the aperture setting.

To change the setting, from the Main Menu, select Setup, then Supply. If password protection is enabled, press **Feed/Cut** three times, then press **Enter/Pause** before you see the Setup Menu options. Then, follow these steps.

1. Press **←** or **→** until you see

SUPPLY Supply Type →

2. Press Enter/Pause to set the supply type option. The current setting is displayed, for example:

SUPPLY TYPE ← Black Mark →

3. Press **←** or **→** to see the other options. After you display the option you want, press **Enter/Pause**. Press **Escape/Clear** until you see the Main Menu.

Setting the Ribbon

You have to tell the printer if your supplies require a ribbon. To change the setting, from the Main Menu, select Setup, then Supply. Then, follow these steps.

1. Press ← or → until you see

SUPPLY Ribbon	→
------------------	---

2. Press **Enter/Pause** to set the ribbon option. The current setting is displayed, for example:

RIBBON ← Yes	→
-----------------	---

3. Press ← or → to see the other options. After you display the option you want, press **Enter/Pause**. Press **Escape/Clear** until you see the Main Menu.

Note: If you set the Ribbon option to **Yes**, install a ribbon before printing. If you want to use a high energy ribbon, select high energy for the ribbon.

Setting the Speed

You can change the print speed for bar codes or graphics. If you select "default" for speed, formats with serial bar codes automatically print at 2.5 ips and formats with parallel bar codes print at 6.0 ips. 12.0 ips printing is an option that must be purchased separately.

Note: If you change the speed, you must resend your formats or turn the printer off and back on before the change takes effect.

To change the setting, from the Main Menu, select Setup, then Supply. Then, follow these steps.

1. Press ← or → until you see

SUPPLY	
← Speed	→

2. Press **Enter/Pause** to set the speed option. The current setting is displayed, for example:

SPEED	
← Default	

3. Press ← or → to see the other options. After you display the option you want, press **Enter/Pause**. Press **Escape/Clear** until you see the Main Menu.

Note: For additional high speed printing information, see Chapter 8, "Printing."

Setting the Feed Mode

You can use continuous or on-demand printing. On-demand printing allows you to remove a label before printing the next one.

To change the setting, from the Main Menu, select Setup, then Supply. Then, follow these steps.

1. Press **←** or **→** until you see

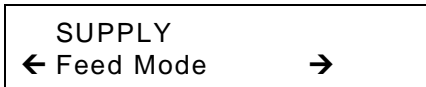

SUPPLY
← Feed Mode →

2. Press **Enter/Pause** to set the feed mode. The current setting is displayed, for example:

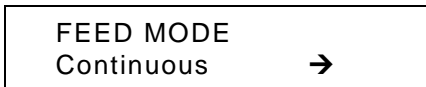

FEED MODE
Continuous →

3. Press **←** or **→** to see the other option. After you display the option you want, press **Enter/Pause**. Press **Escape/Clear** until you see the Main Menu.

Setting the Backfeed

Backfeed works by advancing each printed label to the desired dispense position. Once that label is removed, the next label to be printed is backed up underneath the printhead. In continuous mode, only the last label in the batch is advanced to the dispense position. Extended backfeed is available on this printer with a knife installed. Extended backfeed feeds a tag far enough out to be cut and backfeeds the next tag to the printhead line.

Extended backfeed eliminates *printed* tags being left between the printhead and knife. Extended backfeed works with the selected cut modes. Refer to the optional *Packet Reference Manual* to learn how to define the Backfeed Control Packet. Extended backfeed **does not** work with non-indexed (continuous) supply/mode. Do not use backfeed (normal or extended) with supplies less than 0.75 inches.

Note: We recommend using 0.5-inch gap supplies in peel mode when backfeed is disabled.

To change the setting, from the Main Menu, select Setup, then Supply. Then, follow these steps.

1. Press ← or → until you see

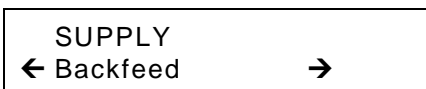

A rectangular box representing a printer's menu screen. At the top, the word "SUPPLY" is centered. Below it, the text "← Backfeed →" is displayed, indicating that the "Backfeed" option is currently selected and can be navigated to using left or right arrow keys.

2. Press **Enter/Pause** to set the backfeed option. The current setting is displayed, for example:

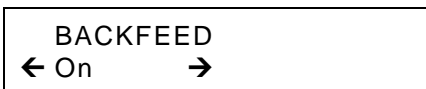

A rectangular box representing a printer's menu screen. At the top, the word "BACKFEED" is centered. Below it, the text "← On →" is displayed, indicating that the "On" option is currently selected and can be navigated to using left or right arrow keys.

3. Press ← or → to see the other options. After you display the option you want, press **Enter/Pause**. Press **Escape/Clear** until you see the Main Menu.

Changing the Position Settings

This menu includes selections to change the print, supply, margin, cut, and dispense positions along with the backfeed distance.

When you see

Enter print pos
[-450/450]: +0

Feed/Cut acts as a toggle switch to change the value by 10 or 1. For example, to make the print position 23 (from the default of 0), press **Feed/Cut**, then press **←** twice (20), press **Feed/Cut** again and press **→** three times (23).

Setting the Print Position

This function adjusts where data prints vertically on the supply. Adjust the print if it is too close to the top or bottom of the supply, or overtypes the pre-printed area. One dot is 0.0049 inch.

- ◆ If the data is too close to the bottom, increase the number.
- ◆ If the data is too close to the top, decrease the number.

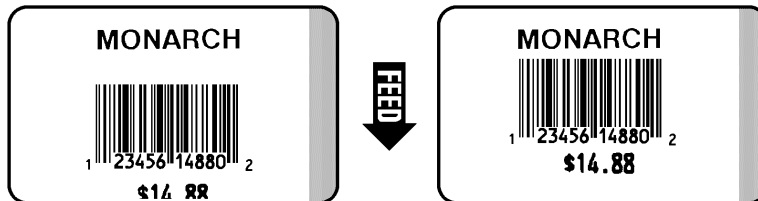

Note: Changing this setting only affects new formats sent to the printer.

To change the setting, from the Main Menu, select Setup, Supply, then Positioning. Then, follow these steps.

1. Press ← or → until you see

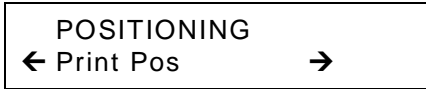

POSITIONING
← Print Pos →

2. Press **Enter/Pause**. The current setting is displayed, for example:

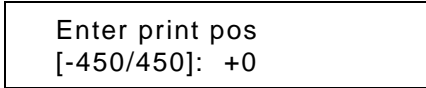

Enter print pos
[-450/450]: +0

3. Press ← or → to change the print position. Pressing ← decreases the value (moves the image down); → increases it (moves the image up).
4. Press **Enter/Pause** when the number you need appears. Press **Escape/Clear** until you see the Main Menu.

Setting the Supply Position

This function adjusts the machine to print at the vertical 0,0 point on the supply.

Note: The supply position adjustment should only be made on initial printer setup. For format adjustments, change the print position.

You may need to adjust the supply in or out to allow

- ◆ tags and labels to be removed.
- ◆ die cut labels to be removed easily.

The adjustments are in dots (0.0049 inch).

- ◆ Increase the number to feed more supply out of the chute.
- ◆ Decrease the number to feed less supply out of the chute.

This option takes effect on the next label or tag printed. Changing supply position may also affect print position.

To change the setting, from the Main Menu, select Setup, Supply, then Positioning. Then, follow these steps.

1. Press **←** or **→** until you see



```
POSITIONING
← Supply Pos      →
```

2. Press **Enter/Pause**. The current setting is displayed, for example:

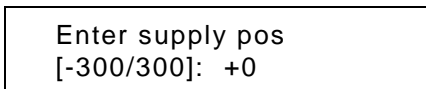

```
Enter supply pos
[-300/300]: +0
```

3. Press **←** or **→** to change the supply position. Pressing **←** decreases the value (feeds less supply); **→** increases it (feeds more supply).
4. Press **Enter/Pause** when the number you need appears. Press **Escape/Clear** until you see the Main Menu.

Setting the Margin Position

This function adjusts where the format prints horizontally on the supply. The adjustments are in dots (0.0049 inch), which is the smallest measurement the printer recognizes.

The width of the print area depends on your supply size. Maximum width is four inches. When you move the image to the right or left on the supply, avoid moving the image too close to either edge, because it may not print.

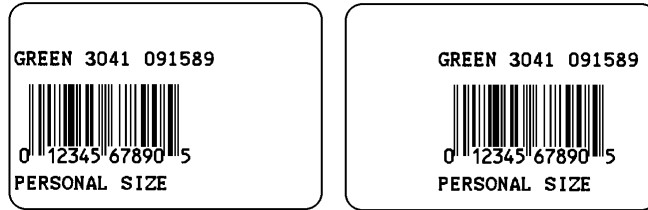

Print too far to the left.

Print too far to the right.

- ◆ If the data is too close to the left side, increase the number.
- ◆ If the data is too close to the right side, decrease the number.

Note: Changing this setting only affects new formats sent to the printer.

To change the setting, from the Main Menu, select Setup, Supply, then Positioning. Then, follow these steps.

4. Press **←** or **→** until you see



5. Press **Enter/Pause**. The current setting is displayed, for example:

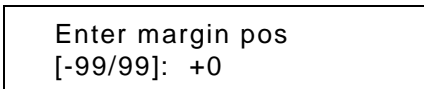

6. Press **←** or **→** to change the margin position. Pressing **←** decreases the value (moves the image toward the left side of the supply); **→** increases it (moves the image toward the right side of the supply).
7. Press **Enter/Pause** when the number you need appears. Press **Escape/Clear** until you see the Main Menu.

Setting the Cut Position

This function adjusts where the tag is cut. The printer adjusts the cut position according to the black marks on the supply. You may need to adjust for aperture supplies. Increase to move the cut up; decrease to move the cut down.

To change the setting, from the Main Menu, select Setup, Supply, then Positioning. Then, follow these steps.

1. Press **←** or **→** until you see

A rectangular box representing a printer screen. The text inside reads "POSITIONING" at the top, followed by "← Cut Pos" on the left and "→" on the right.

POSITIONING
← Cut Pos →

2. Press **Enter/Pause**. The current setting is displayed, for example:

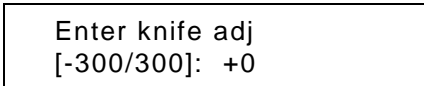
A rectangular box representing a printer screen. The text inside reads "Enter knife adj" followed by "[-300/300]: +0" on the next line.

Enter knife adj
[-300/300]: +0

3. Press **←** or **→** to change the cut position. Pressing **←** decreases the value (moves the cut down); **→** increases it (moves the cut up).

Note: We do not recommend setting a positive cut position while using extended backfeed. You may cut off the leading edge of the next tag.

4. Press **Enter/Pause** when the number you need appears. Press **Escape/Clear** until you see the Main Menu.

Setting the Dispense Position

This function adjusts the stopping point of the label.

To change the setting, from the Main Menu, select Setup, Supply, then Positioning. Follow these steps.

1. Press ← or → until you see

POSITIONING ←Dispense Pos →

2. Press **Enter/Pause**.

DISPENSE POS [50/200]: +65

3. Press ← or → to change the dispense position. Pressing ← decreases the value; → increases it.
4. Press **Enter/Pause** when the number you need appears. Press **Escape/Clear** until you see the Main menu.

Setting the Backfeed Distance

This is the amount to move the label backwards. The backfeed distance cannot be greater than the dispense position. If you make the backfeed distance greater than the dispense position, the dispense position automatically changes to match the backfeed distance.

The backfeed distance should equal the dispense position. An exception is when you are tearing labels, instead of peeling. Then, the backfeed distance must be 30 dots (0.15 inches) less than the dispense position to account for improper tearing of butt cut supplies. You will have a 30-dot non-print zone on your supply, but this prevents exposed adhesive under the printhead.

To change the setting, from the Main Menu, select Setup, Supply, then Positioning. Follow these steps.

1. Press ← or → until you see

```
POSITIONING
← Backfeed Dis
```

2. Press **Enter/Pause**.

```
BACKFEED DIS
[10/200]: +65
```

3. Press ← or → to change the dispense position. Pressing ← decreases the value; → increases it.
4. Press **Enter/Pause** when the number you need appears. Press **Escape/Clear** until you see the Main menu.

Using Batch Separators

A batch separator is an extra tag printed in between batches with a pinstripe pattern. If you select "Long" for the separator, a double-length (two tags) separator prints. For non-indexed supply, the batch separator is always six inches long. If you have the Monarch® 928™ stacker installed, the batch separator is 3.66 inches long. The name of the batch is shown on the batch separator.

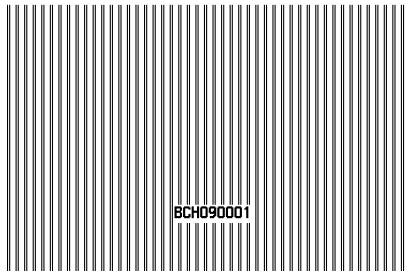

Batch Separator

Note: Changing this setting only affects new formats sent to the printer.

To change the setting, from the Main Menu, select Setup, then Supply. Then, follow these steps.

1. Press **←** or **→** until you see

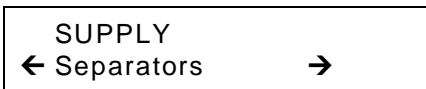

2. Press **Enter/Pause** to set the batch separators option. The current setting is displayed, for example:



3. Press **←** or **→** to see the other options. After you display the option you want, press **Enter/Pause**. Press **Escape/Clear** until you see the Main Menu.

Using Skip Index

You can use the skip index mode to skip (or ignore) a sense mark and print an image over multiple labels, if necessary. For example, if you have 4.0" long supplies loaded, but your image is 8.0" long, enable skip index mode to print the 8.0" long image on two labels. The image length is determined by the format header. See your System Administrator or the optional *Packet Reference Manual* for more information. The skip index feature is useful when you have a **single** format that contains two labels, such as a shelf label and a carton label.

Note: When designing the format, make sure text or graphics do not print in the gap of label rolls.

To change the setting, from the Main menu, select Setup, then Supply.

1. Press ← or → until you see



A rectangular box representing a screen display. At the top, the word "SUPPLY" is centered. Below it, a left-pointing arrow "←" is followed by the text "Skip Index".

2. Press **Enter/Pause** to set the skip index mode. You will see the current setting, for example:



A rectangular box representing a screen display. At the top, the words "SKIP INDEX" are centered. Below them, the word "No" is centered, followed by a right-pointing arrow "→".

3. Press ← or → to see the other options. After you display the option you want, press **Enter/Pause**. Press **Escape/Clear** until you see the Main Menu.

Setting the Knife Control

You may notice unevenly cut tags on one end or the other of your supply (one end may appear longer than the other). Use the knife control adjustment to balance the cut tag length from tag-to-tag.

You may need to make this adjustment

- ◆ on initial printer setup.
- ◆ if you load a different supply type (thickness) from the last ones printed.
- ◆ when you change the print speed.
- ◆ when you change to a different tag size from the last ones printed.

To change the setting, from the Main Menu, select Setup, then Supply. Then, follow these steps.

1. Press **←** or **→** until you see

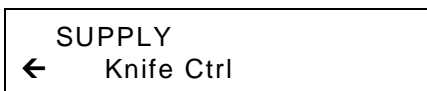

```
SUPPLY
← Knife Ctrl
```

2. Press **Enter/Pause**. The current setting is displayed, for example:

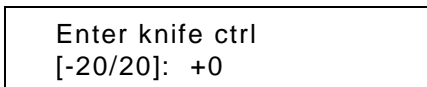

```
Enter knife ctrl
[-20/20]: +0
```

3. Press **←** or **→** to change the knife control. You may need to experiment and cut a few test tags to check the tag cut length. Pressing **←** decreases the value; **→** increases it.

Note: Depending on how unevenly the tags are cut, always start with a small number, such as +- 1 or 2.

4. Press **Enter/Pause** when the number you need appears. Press **Escape/Clear** until you see the Main Menu.

Setting the Error Action

The recovery action from an error condition is in the Setup, Supply Menu. You can change how the printer responds to a bad scan. The choices include normal and overstrike/continue one to five consecutive bad scans. The overstrike pattern is created to prevent someone from using a bad label.

Selecting overstrike and continue 1x-5x sets the number of times the printer prints an overstrike pattern on consecutively bad labels before generating an error. The user must clear the error before operation can continue.

Do not use the overstrike action with

- ◆ Peel mode
- ◆ String tag supplies

For more information about the error actions, see the following table.

Error Action	Standard Peel	Verifier with Peel	RFID with Peel
Overstrike/Continue 1-5	No	No	No
Normal (no overstrike)	Yes	Yes	Yes

Consider this scenario when the error action is set to overstrike/continue 3x: If the printer errors on the first label, an overstrike pattern is printed, but the printer attempts to reprint the image up to three times. If the third consecutive label **also** generates an error, an overstrike pattern is printed; however, the printer stops and the error message is displayed. The operator must resolve the error condition before printing continues.

In the above example, if the third label did **NOT** generate an error,

- ◆ the batch image is printed
- ◆ the consecutive error counter is reset
- ◆ the printer continues processing the batch.

Normal (default)

The printer errors and the condition causing the error is displayed. The error must be cleared before operation can continue. An operator must press **Escape/Clear** to clear the error and continue printing. No overstrike pattern is printed.

Overstrike/Continue 1x Overstrike/Continue 2x Overstrike/Continue 3x Overstrike/Continue 4x Overstrike/Continue 5x

The printer prints an overstrike pattern on one, two, three, four, or five consecutive labels and stops printing after the selected number of overstrike patterns have been printed. An operator must press **Escape/Clear** to clear the error and continue printing. Do not use the label with the overstrike pattern.

Note: The printer re-calibrates (feeds a blank label) after a motion or verifier error.

To change the setting, from the Main Menu, select Setup, then Supply. Then follow these steps.

1. Press **←** or **→** until you see

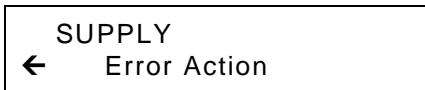

2. Press **Enter/Pause**. The current setting is displayed, for example:

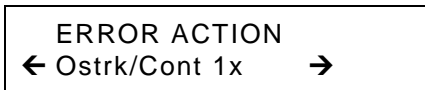

3. Press **←** or **→** to see the other options. After you display the option you want, press **Enter/Pause**.
4. Press **Escape/Clear** until you see the Main Menu.

Note: Depending on the selected error action, you may or may not see a label with the overstrike pattern.

Setting the Print Contrast

The print contrast controls the darkness of the printing on your supply. The range is **-699** to **+699** and the default is **0**. Having the correct print contrast setting is important because it affects how well your bar codes scan and how long your printhead lasts. You can use a verifier to check the bar code print quality.

Main Menu

Cancel All	Print Mode	Batch Entry	Repeat Batch	Batch Options	Setup	Scripts	Diagnostics
Supply	Contrast	Defaults	Network	Port Settings	Flash Memory	Verifier	RFID

High contrast settings may

- ◆ require additional printhead cleaning.
- ◆ create bar code growth, leading to reduced scanning.

CAUTION: Setting the print contrast higher than 399 reduces the printhead warranty to 100,000 inches and may damage the printhead.

1. From the Main Menu, press **←** or **→** until you see

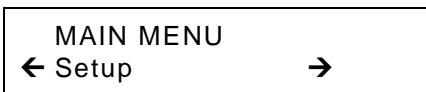

2. Press **Enter/Pause**. You will be at the Setup menu. Press **←** or **→** until you see

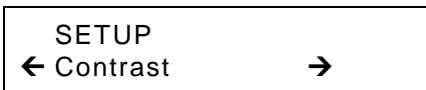

3. Press **Enter/Pause**. The current setting is displayed, for example:

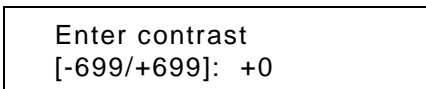

4. Press **←** or **→** to change the contrast. Pressing **→** darkens the print; **←** lightens the print.

Feed/Cut acts as a toggle switch to change the value by 10 or 1. For example, to make the contrast 50 (from the default of 0), press **Feed/Cut**, then press → five times (50).

5. Press **Enter/Pause** to select either "Yes" or "No" to print a test label and check the print contrast. Press **Enter/Pause**.
6. Press **Escape/Clear** until you see the Main Menu.

We recommend you check the bar code print quality with a bar code verifier. If you do not have a bar code verifier or scanner, check the bar code visually. A bar code that is in spec has complete bars, clear spaces, and small alphanumeric characters look complete. An in spec bar code may not look as good as one that is too dark, but it has the highest scan rate.

ROADWAY SYSTEMS



DAYTON, OHIO

Dark

BROADWAY SYSTEMS



DAYTON, OHIO

IN SPEC

BROADWAY SYSTEMS



DAYTON, OHIO

Light

Enabling the Verifier

The verifier scans and checks the quality of bar codes as they are printed. The optional verifier must be purchased separately. The verifier scans parallel bar codes; it cannot scan serial bar codes.

The verifier must be enabled and set up before you can scan bar codes. For additional set up procedures, refer to your verifier's *Operating Instructions*.

To enable the verifier, from the Main Menu, select Setup, then Verifier. Then follow these steps.

1. Press ← or → until you see

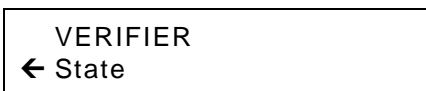

A rectangular box containing the text "VERIFIER" on the top line and "← State" on the bottom line.

2. Press **Enter/Pause**. The current setting is displayed, for example:

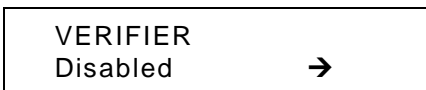

A rectangular box containing the text "VERIFIER" on the top line, "Disabled" on the bottom left, and a right-pointing arrow "→" on the bottom right.

3. Press ← or → to see the other option. After you display the option you want, press **Enter/Pause**. Press **Escape/Clear** until you see the Main Menu.

SETTING COMMUNICATIONS

5

This chapter tells you how to set the serial or parallel communication values. These values provide the link for normal online printing.

Main Menu

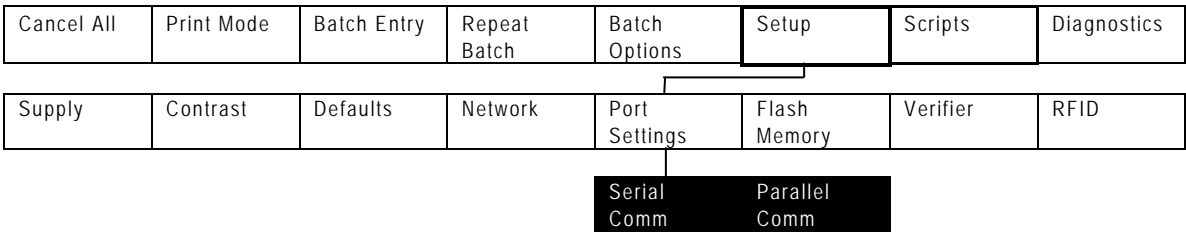

You need to set your Serial Comm values to match your computer's online communications. Before entering the communication values, see your System Administrator.

The **serial** communication values are listed in the table below.

Option	Choices	Default
Baud rate	1200/2400/4800/9600/19200/ 38400/57600/115200	9600
Word length	7/8	8
Stop bits	1/2	1
Parity	None/Odd/Even	None
Flow control	None/Xon/Xoff/DTR/CTS	DTR
Reset	No/Yes	No

Setting the Baud Rate

To change the setting, from the Main Menu select Setup, Port Settings, then Serial Comm. If password protection is enabled, press **Feed/Cut** three times, then press **Enter/Pause** before you see the Setup Menu options. Then, follow these steps.

1. Press **←** or **→** until you see

SERIAL COMM Baud Rate →

2. Press **Enter/Pause**. The current setting is displayed, for example:

BAUD RATE ← 9600 →

Press **←** or **→** to display the baud rate you need, then press **Enter/Pause**. Press **Escape/Clear** until you see the Main Menu.

Setting the Word Length

To change the setting, from the Main Menu select Setup, Port Settings, then Serial Comm. Then, follow these steps.

1. Press **←** or **→** until you see

SERIAL COMM ← Word Length →
--

2. Press **Enter/Pause**. The current setting is displayed, for example:

WORD LENGTH ← 8

3. Press **←** or **→** to display the word length you need, then press **Enter/Pause**. Press **Escape/Clear** until you see the Main Menu.

Setting the Stop Bits

To change the setting, from the Main Menu select Setup, Port Settings, then Serial Comm. Then, follow these steps.

1. Press ← or → until you see

```
SERIAL COMM
← Stopbits      →
```

2. Press **Enter/Pause**. The current setting is displayed, for example:

```
STOPBITS
1          →
```

3. Press ← or → to display the number of stop bits you need, then press **Enter/Pause**. Press **Escape/Clear** until you see the Main Menu.

Setting the Parity

To change the setting, from the Main Menu select Setup, Port Settings, then Serial Comm. Then, follow these steps.

1. Press ← or → until you see

```
SERIAL COMM
← Parity      →
```

2. Press **Enter/Pause**. The current setting is displayed, for example:

```
PARITY
None     →
```

3. Press ← or → to display the parity you need, then press **Enter/Pause**. Press **Escape/Clear** until you see the Main Menu.

Setting the Flow Control

To change the setting, from the Main Menu select Setup, Port Settings, then Serial Comm. Then, follow these steps.

1. Press ← or → until you see

```
SERIAL COMM
← Flow Control →
```

2. Press **Enter/Pause**. The current setting is displayed, for example:

```
FLOW CONTROL
← DTR →
```

3. Press ← or → to display the flow control you need, then press **Enter/Pause**. Press **Escape/Clear** until you see the Main Menu.

XON is 17; XOFF is 19. Set flow control to DTR for PC computers (unless you have XON/XOFF software).

Resetting to Default Values

To change the setting, from the Main Menu select Setup, Port Settings, then Serial Comm. Then, follow these steps.

1. Press → until you see

```
SERIAL COMM
← Reset
```

2. Press **Enter/Pause**.

```
Are you sure?
No →
```

Press ← or → to make your selection, then press **Enter/Pause**. If you select "Yes," the following defaults are restored: 9600 baud, No parity, 8 bit word length, and 1 stop bit. Press **Escape/Clear** until you see the Main Menu.

Using Parallel Communications

The parallel communications menu allows you to set the values for the active parallel port. The values are listed in the table below.

Note: Turn the printer off and back on when you change the port or mode settings.

Option	Choices	Default
Port	External/Internal	External
Mode	Compatible/IEEE-1284	Compatible (Centronics mode)

Setting the Port

To change the setting, from the Main Menu select Setup, Port Settings, then Parallel Comm. Then, follow these steps.

1. Press **←** or **→** until you see

```
PARALLEL COMM
Port                →
```

2. Press **Enter/Pause**.

```
PORT
External           →
```

3. Use **←** or **→** to select either "External" or "Internal." Press **Enter/Pause**. The internal port is used for printer options installed inside the printer, such as the Ethernet communication port. The external port is used to connect a printer cable or external device directly to the parallel port.
4. Press **Escape/Clear** until you see the Main Menu.

Setting the Mode

To change the setting, from the Main Menu select Setup, Port Settings, then Parallel Comm. Then, follow these steps.

1. Press ← or → until you see

```
PARALLEL COMM
← Mode
```

2. Press **Enter/Pause**.

```
MODE
Compatible →
```

3. Use ← or → to select either "Compatible" or "IEEE1284." Press **Enter/Pause**. Use compatible mode for a computer connection to the printer with a parallel cable. Use IEEE-1284 for bi-directional Ethernet communications. See Appendix B, "Accessories & Options" for more information about Ethernet options.
4. Press **Escape/Clear** until you see the Main Menu.

SETTING DEFAULTS

6

This chapter explains how to select the monetary sign, secondary sign, decimal places, slashed zero, power-up mode, prompt set, imaging errors, ignore configuration packets, disable error retry, and adjust the image length.

This chapter also explains how to format flash, check the available flash memory, and pack flash memory.

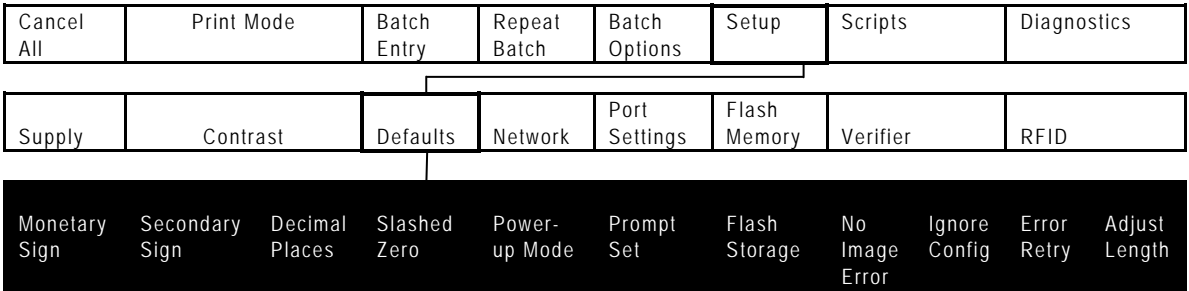

You can set your printer configurations to fit your daily operation, using either the offline menus or the online configuration option. After an option is selected in the online configuration or offline Setup Menu, the option is saved when the printer is turned off.

The default options are listed in the table below.

Option	Choices	Default
Monetary sign	None/USA/UK/Japan/ Germany/France/Spain/ Italy/Sweden/Finland/ Austria/India/Russia/ Korea/Thailand/China/Euro-Dollar	USA
Secondary Sign	No/Yes	No
Decimal Places	0/1/2/3	2
Slashed Zero	No/Yes	No
Power-up Mode	Online/Offline	Online
Prompt Set	English/French/German/ Spanish-ES/Japanese/Portuguese/ Italian/Swedish/Spanish 2/ Danish/Dutch/Finnish/Norwegian	English
Numeric Format	Default, Arabic-Indic, Eastern Arabic	Default
Flash Storage	Disabled/Enabled	Disabled
No Image Errors	Disabled/Enabled	Disabled
Ignore Config	Disabled/Enabled	Disabled
Error Retry	Disabled/Enabled	Enabled
Adjust Length	-30 to 30	0

The monetary sign, secondary sign, and decimal places options are used in conjunction with option **42**. Refer to the optional *Packet Reference Manual* for more information.

Note: The settings for Monetary Sign, Secondary Sign, Slashed Zero, and Decimal Places are applied when a format is downloaded. Changing the settings does **not** affect batches already in the printer.

Setting the Monetary Sign

You can also select **None** if you do not want a monetary sign to print in price fields. The monetary signs available for 15 countries are shown in the table below.

Country	Currency	Description
USA	\$	dollar
UK	£	pound
Japan	¥	yen
Germany	₤	deutsche mark
France	F	franc
Spain	P	peseta
Italy	L.	lira
Sweden	Kr	krona
Finland	₤	markka
Austria	₯	schilling
India	Rs	rupee
Russia	₮	ruble
Korea	₩	won
Thailand	฿	baht
China	¥	yuan
Euro-Dollar	€	euro-dollar

To change the setting, from the Main Menu, select Setup, then Defaults. If password protection is enabled, press **Feed/Cut** three times, then press **Enter/Pause** before you see the Setup Menu options. Then, follow these steps. To exit an option without changing the setting, press **Escape/Clear**.

1. Press **←** or **→** until you see



2. Press **Enter/Pause**. The current setting is displayed, for example:

MONETARY SIGN	
← USA	→

3. Press ← or → until you see the country's monetary sign you want.
4. Press **Enter/Pause**. Press **Escape/Clear** until you see the Main menu.

Setting the Secondary Sign

If you select USA as the monetary sign, you can print amounts less than \$1.00 either by using a dollar sign and decimal (\$0.30) or by using a cent sign (30¢).

- ◆ If you set the secondary sign option to **No**, prices under \$1.00 will print like this: **\$.45**
- ◆ If you set the secondary sign option to **Yes**, prices under \$1.00 will print like this: **45¢**

The same option applies to the appropriate secondary sign for monetary signs other than USA.

To change the setting, from the Main Menu, select Setup, then Defaults. Then, follow these steps.

1. Press ← or → until you see

DEFAULTS	
← Secondary Sign	→

2. Press **Enter/Pause**. The current setting is displayed, for example:

SECONDARY SIGN	
No	→

3. Press ← or → until you see the option you want. Then press **Enter/Pause**. Press **Escape/Clear** until you see the Main menu.

Setting the Number of Decimal Places

You can set the printer for 0, 1, 2, or 3 places after the decimal in a price field. In U.S. currency, you might print prices like this: \$24.00 (**2** decimal places) or like this: \$24 (**0** decimal places).

1. Press **←** or **→** until you see

```

  DEFAULTS
← Decimal Places →
```

2. Press **Enter/Pause**. The current setting is displayed, for example:

```

  DECIMAL PLACES
← 2 →
```

3. Press **←** or **→** until you see the option you want. Then press **Enter/Pause**. Press **Escape/Clear** until you see the Main menu.

Setting the Slashed Zero Appearance

The slashed zero feature lets you select how you want the zero character printed; either without a slash, 0 or, with a slash, 0̄.

Standard or reduced fonts print the slashed zero character (0̄). Bold and OCR fonts print the standard zero (0) only. The slashed zero selection does **not** take effect until the format is sent to the printer again. If you change the way zero is printed, you must resend your formats.

To change the setting, from the Main Menu, select Setup, then Defaults. Then, follow these steps.

1. Press **←** or **→** until you see

```

  DEFAULTS
← Slashed Zero →
```

2. Press **Enter/Pause**. The current setting is displayed, for example:

```

  SLASHED ZERO
No →
```

3. Press **←** or **→** until you see the option you want. Then press **Enter/Pause**. Press **Escape/Clear** until you see the Main Menu.

Setting the Power-Up Mode

Power-up mode lets you decide how your printer starts each time you turn it on. If you want the printer to be ready to start printing when it is turned on, use the Online power-up mode. If you want the operator to perform some other task first, use the Offline power-up mode.

To change the setting, from the Main Menu, select Setup, then Defaults. Then, follow these steps.

1. Press **←** or **→** until you see



DEFAULTS
← Powerup Mode →

2. Press **Enter/Pause**. The current setting is displayed, for example:

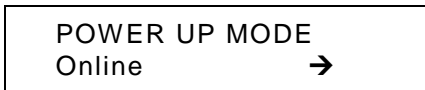

POWER UP MODE
Online →

3. Press **←** or **→** until you see the option you want. Then press **Enter/Pause**. Press **Escape/Clear** until you see the Main menu.

Changing the Prompt Set

Prompt set determines which language displays on the printer's menu. You can select English, French, German, Spanish-ES, Japanese, Portuguese, Italian, Swedish, Spanish 2, Danish, Dutch, Finnish, and Norwegian. Some prompts may remain in English, even if you select a different language.

To change the setting, from the Main Menu, select Setup, then Defaults. Then, follow these steps.

1. Press **→** until you see



DEFAULTS
← Prompt Set →

2. Press **Enter/Pause**. The current setting is displayed, for example:

PROMPT SET English →
--

3. Press ← or → until you see the option you want. Then press **Enter/Pause**. Press **Escape/Clear** until you see the Main menu.

Note: This option only affects the displayed prompts. It does not change what is printed by the printer.

Setting the Numeric Format

Numeric format determines how numeric values appear in your printed data.

To change the setting, from the Main Menu, select Setup, then Defaults. Then, follow these steps.

1. Press ← or → until you see Numeric Format.

DEFAULTS ← Numeric Format →

2. Press **Enter/Pause**. The current setting is displayed, for example:

NUMERIC FORMAT ← Arabic-Indic →

3. Press ← or → until you see the option you want. Then press **Enter/Pause**. Press **Escape/Clear** until you see Main menu.

Note: This option only affects the prompts; it does not affect what prints.

Examples

Default: 95% cotton

Arabic Numerals with Arabic Characters:

Arabic-Indic: % ٦٨ بوليسٽر

Eastern-Arabic: % ٦٨ بوليسٽر

Using Flash Storage

Flash storage allows packets (with "R" or "N" selectors) to be stored in flash memory, instead of volatile RAM. Packets stored in flash memory are saved when the printer is turned off. However, flash memory storage is limited.

Note: You must format flash memory before enabling this option. Formatting flash memory is only required once during initial printer setup.

To change the setting, from the Main Menu, select Setup, then Defaults. Then, follow these steps.

1. Press **→** until you see

```
DEFAULTS
← Flash Storage
```

2. Press **Enter/Pause**. The current setting is displayed, for example:

```
FLASH STORAGE
Disabled      →
```

3. Press **←** or **→** until you see the option you want. Then press **Enter/Pause**. Press **Escape/Clear** until you see the Main menu.

Disabling Image Errors

You can disable image error reporting. Image errors occur when there is a problem producing a complete label. You must press **Escape/Clear** to clear an image error.

Image errors include

600	unable to image batch	614	portion of field off label
601	problem during imaging	615	invalid PDF417 bar code data
603	missing batch	618	invalid font size
611	invalid font, bar code or density	620	missing font data
612	missing batch data	621	invalid downloaded font
613	reference point off label	622	not enough font memory

Note: With this option enabled, the format may not print as expected and no error is reported. For example, bar codes require a non-print zone and if a bar code is placed too close to the edge of the label, no error is reported and the bar code may not scan properly.

Error 616 (bar code dot shifting failed) is always reported.

To change the setting, from the Main Menu, select **Setup**, then **Defaults**. Then, follow these steps.

1. Press **←** or **→** until you see

```

  |-----|
  |  DEFAULTS  |
  |← No Image Error →|
  |-----|

```

2. Press **Enter/Pause**. The current setting is displayed, for example:

```

  |-----|
  | NO IMAGE ERRORS |
  | Disabled        →|
  |-----|

```

3. Press **←** or **→** until you see the option you need. Then press **Enter/Pause**.

4. Press **Escape/Clear** until you see the Main Menu.

Ignoring Configuration Packets

You can ignore all online configuration packets. If the printer receives data from a host system or software package that includes online configuration packets with the format, those online configuration packets can be ignored. Ignoring these packets is useful when you cannot change your host's data or when you want the printer to operate as specified through the printer's menu.

Note: We recommend changing your host's data stream, but if that is not possible, enable this option.
Use caution if ignoring online configuration packets, because the printer may need the configuration for proper operation.

To change the setting, from the Main Menu, select **Setup**, then **Defaults**. Then, follow these steps.

1. Press **←** or **→** until you see

DEFAULTS ← Ignore Config →

2. Press **Enter/Pause**. The current setting is displayed, for example:

IGNORE CONFIG Disabled →

3. Press **←** or **→** until you see the option you want. Then press **Enter/Pause**.
4. Press **Escape/Clear** until you see the Main Menu.

Using Error Retry Mode

You can set the printer to enable or disable error retries. The default is enabled, which means the printer tries to reprint the label where the error occurred and then continues printing the remainder of the batch. Depending on your environment, you may not want jobs reprinted.

- ◆ Select “enable error retry” to reprint the batch (job) that was in process when the error occurred.
- ◆ Select "disable error retry" to cancel the batch where a supply error occurs while the batch. For example, an error occurs on label 5 with a batch quantity of 25, the batch is canceled and the remaining 20 labels are not printed. The host must know which batch was canceled and resend it.

Note: We only recommend disabling error retry when sending batches of one or with RFID supplies. Use caution disabling error retry because batches are deleted and, therefore, may be incomplete. The host must resend the canceled batch.

To change the setting, from the Main Menu, select **Setup**, then **Defaults**. Then, follow these steps.

1. Press **←** or **→** until you see



```
DEFAULTS
← Error Retry →
```

2. Press **Enter/Pause**. You see



```
ERROR RETRY
← Enabled
```

3. Press **←** or **→** until you see the option you want. Then, press **Enter/Pause**.
4. Press **Escape/Clear** until you see the Main menu.

Adjusting the Image Length

Using this setting requires continuous (non-indexed) supply. The printer ignores this setting (does not error) when using other supply types.

This setting increases or decreases the image length based on the percentage entered. Values are in tenths of a percent.

Note: If a print image is defined close to the label's edge and adjust image length is set **to a negative value**, the printed image may not be complete. Some of the image may be lost. Verify your printed image is complete.

Examples

Format A is 10.0 inches long (as defined in the format header).

Image Length is +20

Format A prints 10.20 inches long.

Format B is 6 inches long (as defined in the format header).

Image Length is -30

Format B prints 5.82 inches long.

Note: Refer to the *Packet Reference Manual* for more information about defining the format header.

To change the setting, from the Main Menu, select **Setup**, then **Defaults**. Then, follow these steps.

1. Press **←** or **→** until you see

DEFAULTS ← Adjust Length

2. Press **Enter/Pause**. You see

ADJUST LENGTH [-30/30]: +0

3. Press **←** or **→** to adjust the image's length. Pressing **←** decreases the setting, which reduces the image length by the entered percentage. Pressing **→** increases the setting, which increases the image length by the entered percentage.

Note: Press the left function button to change the amount (by 1 or 10).

4. Press **Enter/Pause** when the number you need appears. Press **Escape/Clear** until you see the Main menu.

Using Flash Memory

The flash memory options are listed in the table below.

Option	Choices	Default
Format Flash	No/Yes	No
Unused Flash	NA	NA
Pack Flash	No/Yes	No

Formatting Flash Memory

Before storing packets in flash memory, downloading a script, or if the printer's firmware is updated, you must format the flash memory.

Formatting flash memory is only required once during initial printer setup.

Note: When you format flash memory, the script and any downloaded TrueType® fonts saved in the printer's flash memory are deleted and must be resent to the printer.

To format flash memory, from the Main Menu, select Setup. Then, follow these steps.

1. Press ← or → until you see

SETUP ← Flash Memory →

2. Press Enter/Pause.

FLASH MEMORY Format Flash →

3. Press Enter/Pause.

Are you sure? No →

4. Press → to display "Yes" and press **Enter/Pause**.

CREATING FLASH FILE SYSTEM 1

The printer's flash memory is cleared and reformatted. *This process may take several minutes.* The printer reboots automatically after formatting flash memory. You need to resend any fonts you want to use to flash memory again. You return to the "Print Mode Ready" menu.

Checking Available Flash Memory

If you receive errors when downloading a script or other packets, make sure you have enough flash memory available.

Note: When you format flash memory, the script and any downloaded TrueType fonts saved in the printer's flash memory are deleted and must be resent to the printer.

To check available flash memory, from the Main Menu, select Setup. Then, follow these steps.

1. Press ← or → until you see

```
SETUP
← Flash Memory →
```

2. Press **Enter/Pause**.
3. Press ← or → until you see

```
FLASH MEMORY
← Unused Flash →
```

4. Press **Enter/Pause**. You see the number (in bytes) of available flash memory.

```
Unused Flash
← 1006216_
```

5. Press **Escape/Clear** until you see the Main menu.

Packing Flash Memory

Packing flash memory permanently removes any deleted files from memory. Periodically select this option to "clean up" the printer's memory. Any deleted files are removed from memory when you pack flash.

To pack flash memory, from the Main Menu, select Setup. Then, follow these steps.

1. Press **←** or **→** until you see

SETUP ← Flash Memory →

2. Press **Enter/Pause**. Press **←** or **→** until you see

FLASH MEMORY ← Pack Flash

3. Press **Enter/Pause**.

Are you sure? No →
--

4. Press **→** to display "Yes" and press **Enter/Pause**.

All the deleted files in flash memory are permanently erased.

5. Press **Escape/Clear** until you see the Main menu.

Memory Guidelines

Use these basic guidelines when storing files in your printer's memory.

- ◆ Your printer may have volatile RAM (packets deleted when the printer is turned off), non-volatile RAM (packets saved when the printer is turned off), and flash memory (packets saved when the printer is turned off). Each printer has a different limit of available memory.
- ◆ Before you save any packets in flash memory, you must format flash memory first. See "Formatting Flash Memory" for more information.
- ◆ Formats, graphics, and check digits can be saved in flash (but they are also duplicated in RAM). Any packets saved in flash cannot exceed the memory available in RAM.
- ◆ Fonts are stored differently in flash. For example, the 9825 printer has very limited flash font memory and one TrueType font may exceed that limit. If you print TrueType or double-byte Asian fonts, use a 9855 or 9860 printer with the extended memory option.
- ◆ There is not a 1-to-1 ratio between the memory in your printer and the memory in your PC. For example, a file that is 5K in Windows may require 15-20K to store in your printer.
- ◆ When using graphics, use the lowest-resolution graphic possible. If your printer uses a 203 dpi printhead, the graphic's resolution should be 150 to 200 dpi. In fact, 96 dpi may work. Try to create the smallest file size possible.
- ◆ Use temporary storage for graphics that are only used once or twice. However, if you have a logo that is used on multiple formats, save the graphic in flash. Once again, try to create the smallest file size possible for your graphic.
- ◆ Each line in a packet requires the same amount of memory. The smaller the format, the less memory required to save it.

Setting Batch Options

You can select Batch Options to change, which prompts appear during Batch Entry mode and set default values for those prompts. Customizing which prompts appear during batch entry can reduce the time it takes to enter data for a format. If the optional knife is not installed, you can prevent those prompts from appearing during batch entry mode. If you set a new default value for an option, that value is used even if the prompt is not displayed. If you do not change a default value for an option, the system default is used if the prompt is not displayed.

Note: Setting batch options requires the optional keypad, which must be purchased separately.

Refer to your keyboard's *Operating Instructions* for more information.

Setting Up the Network Printer

Your System Administrator should refer to the *MonarchNet2™ Operating Instructions* (available on our Web site) for more information about your network printer.

Setting Up the RFID Printer

To set up your RFID printer, refer to the *Packet Reference Manual* or *Application Notes* (available on our Web site). To load supplies or perform care and maintenance, refer to the *RFID Operator's Handbook*.

USING SCRIPTS

This chapter explains how to load, enable, and delete scripts. You can also enable status polling and immediate commands.

Using the Scripts menu requires custom software. It allows you to print data streams written for other printers.

Note: Ignore these menus if you do not use Scripts.

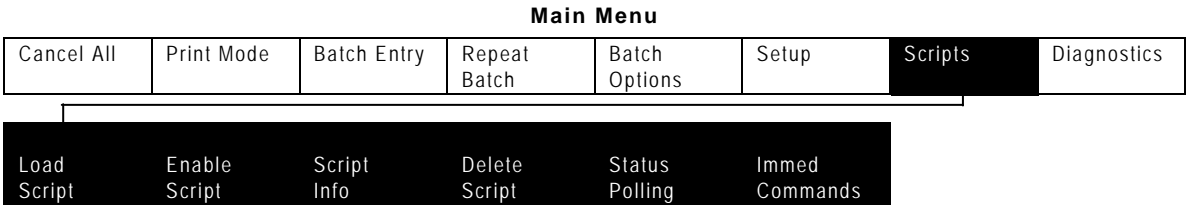

Your System Administrator may limit access to this menu to prevent supply, network, script, or communication settings from being changed. If password protection is turned on, you see

Enter Password -----

when you try to access the scripts menu. Get the password from your System Administrator to continue.

Initial Script Startup Procedures

Before you can start using a script, check the following items:

- ◆ Check to see if a script is already loaded in the printer. See "Viewing Script Information" to continue.
- ◆ Format flash memory, if needed. See "Formatting Flash Memory" in Chapter 6 for more information.
- ◆ Download a script to the printer, if needed. See "Downloading a Script" to continue.

Viewing Script Information

1. To see if your printer has a script loaded from the Main menu, press **←** or **→** until you see

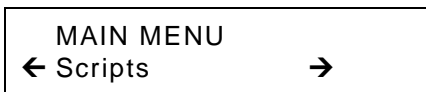

MAIN MENU
← Scripts →

2. Press **Enter/Pause**. If password protection is enabled, press **Feed/Cut2** three times, then press **Enter/Pause** before you see the Scripts Menu options.
3. Press **←** or **→** until you see

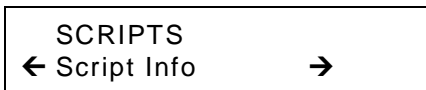

SCRIPTS
← Script Info →

4. Press **Enter/Pause**. What you see depends on the script. If a script is not loaded, you see "No script loaded." If a script is loaded, you see the script name and version number, for example,

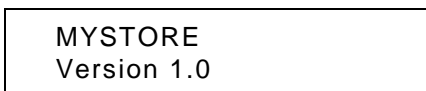

MYSTORE
Version 1.0

If a script is already loaded, see "Enabling a Script," to continue. If you need to download a script, see "Formatting Flash Memory" in Chapter 6.

Downloading a Script

Follow these instructions to download a script from the MS DOS prompt. Set the communication parameters using the MODE command. Then, prepare the printer to accept a script.

1. From the printer's Script Menu, press ← or → until you see

```
SCRIPTS
Load Script    →
```

2. Press Enter/Pause.

```
Script Load
Ready
```

Note: Only one script can be loaded in the printer at a time.

When downloading a script, if you receive an error:

- ◆ Check the available flash memory. See "Checking Available Flash Memory" in Chapter 6 for more information.
- ◆ Format flash memory. See "Formatting Flash Memory" in Chapter 6 for more information.

After downloading a script, if the script does not appear to be loaded, try formatting flash memory and download the script again.

Enabling a Script

The script must be enabled before you can use it.

To enable or disable a script:

1. From the Script Menu, press ← or → until you see

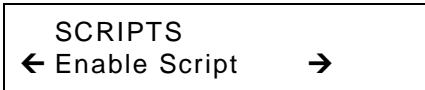

```
SCRIPTS
← Enable Script →
```

2. Press **Enter/Pause**.

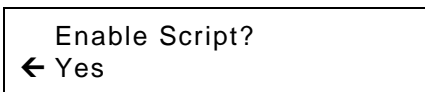

```
Enable Script?
← Yes
```

3. Use ← or → to select either "Yes" or "No" and press **Enter/Pause**. Selecting "Yes" starts the script. Selecting "No" stops the script. If you select "Yes," when you turn off the printer and turn it back on, the script automatically starts.

Once the script is enabled, you will see

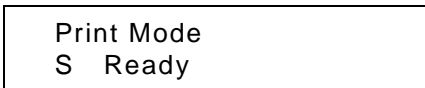

```
Print Mode
S Ready
```

The "S" in the lower left-hand corner of the screen indicates the printer has a script loaded and enabled (the script is running).

Deleting a Script

You can delete a script from the printer's memory.

To delete a script:

1. From the Script Menu, press ← or → until you see

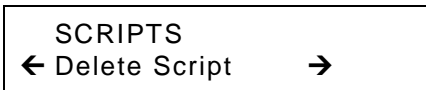

```
SCRIPTS
← Delete Script →
```

2. Press **Enter/Pause**.

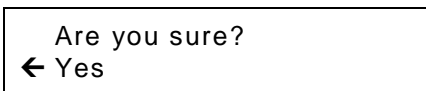

```
Are you sure?
← Yes
```

3. Use ← or → to select either "Yes" or "No" and press **Enter/Pause**.
Selecting "Yes" deletes the current script.

Note: The flash memory used by the script is not available for other scripts or fonts until the flash memory is reformatted. However, when you format flash memory, you must resend the script and any downloaded fonts to the printer.

4. Press **Escape/Clear** until you see the Main Menu.

Enabling Status Polling

Status polling allows you to obtain information about the readiness of the printer and the current (or last received) print job. Your System Administrator can enable status polling while the printer is running in Script mode. To enable status polling:

1. From the Script Menu, press ← or → until you see

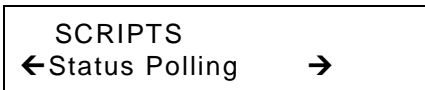

2. Press **Enter/Pause**.

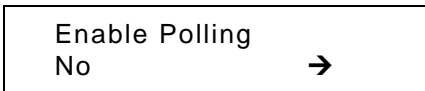

3. Use ← or → to select either "Yes" or "No" and press **Enter/Pause**. The default is "No."

Using Immediate Commands

Your System Administrator can use immediate commands to reset the printer or cancel and repeat batches. Immediate commands are turned on or off through an MPCL packet. Your System Administration should refer to the *Packet Reference Manual* (available on our Web site) for more information about immediate commands and control characters.

Use this option to set whether the ADK script processes or ignores an immediate command control character.

To enable the ADK script to process immediate commands:

1. From the Script Menu, press ← or → until you see

```
SCRIPTS
← Immed Commands
```

2. Press **Enter/Pause**.

```
Enable Immed?
← Yes
```

3. Use ← or → to select either "Yes" or "No" and press **Enter/Pause**. The default is "No."

Selecting "Yes" allows the immediate command control character to be processed by the printer and performs the requested immediate command.

Selecting "No" prevents the script and printer from processing the immediate command control character. Instead, the immediate command control character and immediate command are treated as data.

4. Press **Escape/Clear** until you see the Main Menu.

PRINTING

This chapter explains how to

- ◆ use on-demand mode printing.
- ◆ print an error label.
- ◆ print, pause, restart, cancel, and repeat a batch.

You can send format, batch, and graphic data to the printer from a host. When the printer receives the data, batches begin printing automatically. The optional *Packet Reference Manual* tells how to create, store, and download the data necessary to print batches. You can also use the Monarch® MPCL™ Toolbox utilities to create and download packets.

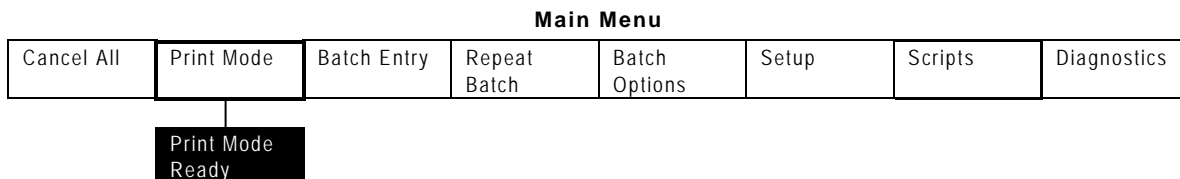

Printing

Before you print, make sure the printer is connected and ready to receive data.

1. Turn on the printer. Your printer is ready to receive and print batches when you see "PRINT MODE Ready."
2. Download a format and a batch. Refer to the optional *Packet Reference Manual* for information on downloading print jobs.
3. The printer prints a strip of labels.
4. Remove the printed labels.

Note: If the printer will be unused for extended periods of time, we recommend leaving the printhead unlatched.

An optional keyboard is also available to enter offline batch data. The keyboard must be purchased separately. If there are offline batches in the print queue, the offline batches print after the downloaded batches have printed.

On-Demand Mode Printing

When this printer is operating in the on-demand mode, the next label prints when the previous label is removed from the printer or when **Feed/Cut** is pressed. The display shows "Printing X of Y" until all the labels in the batch are printed.

If you have purchased the optional peel module, you must use on-demand printing with peel mode. If you are using peel mode, remove the excess backing paper by pulling up across the saw-toothed tear edge. Make sure the backing paper tears at the edge. Hold the leading edge of peeled labels when printing on stock longer than six inches. The minimum feed length for peel mode is 1.5 inches. You must use non-perforated supplies for peel mode. The maximum speed for peel mode is 8.0 ips.

Note: We recommend using 0.5-inch gap supplies in peel mode when backfeed is disabled.

Printing an Error Label

If the printer displays a data error (errors 0-499), press **Feed** to print an error label and continue printing. See your System Administrator about the error label.

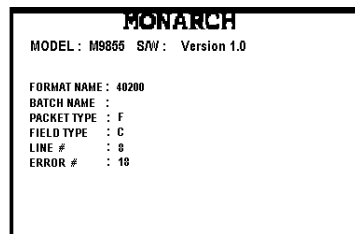

Pausing a Batch

You can pause printing by pressing **Enter/Pause**. You may want to interrupt a batch to make adjustments for:

- ◆ Loading a different roll of supply or a ribbon. See Chapter 2, "Loading Supplies" or Chapter 3, "Loading Ribbon" for more information.
- ◆ Adjusting the supply position or contrast using the Setup menu. See Chapter 4, "Setting Supply Options" for more information.

When you press **Enter/Pause** you will see



You can press **Enter/Pause** to resume printing or press **←** or **→** to display the Pause Menu options.

The following chart shows the Pause Menu options.

Cancel Batch	Cancel All	Print Mode	Restart Batch
-----------------	---------------	---------------	------------------

Restarting a Batch

You can reprint a paused batch from the beginning (using the original quantity).

1. When you press **Enter/Pause**, you will see



2. Press **←** or **→** until you see



3. Press **Enter/Pause**. The batch starts printing from the beginning.

Canceling a Paused Batch

You can cancel a paused batch, delete a format, graphic, or font in memory, or all the batches waiting to print.

Note: Before any format, graphic, or font in memory can be deleted, you must cancel all batches.

Pause Menu

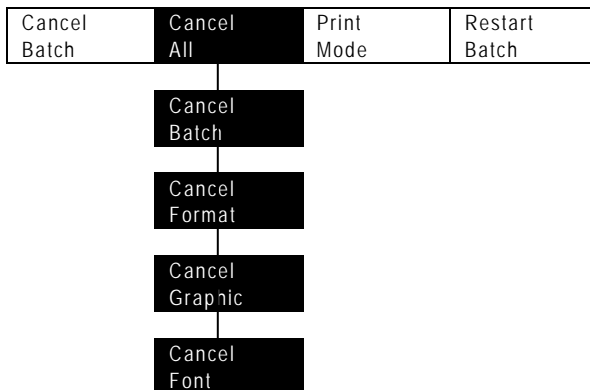

You can cancel a batch by pressing **Escape/Clear** while the batch is printing, or you can use the Pause menu to cancel a batch.

1. Press **Enter/Pause** to interrupt printing.



- ◆ If you want to cancel only the paused batch, skip step 3.
- ◆ If you want to cancel all the batches, skip step 2.

2. To cancel only the paused batch, press **←** or **→** until you see



Then press **Enter/Pause**. The batch is deleted and the printer prints any remaining batches.

3. To cancel all the batches (including the paused batch), press ← or → until you see

PAUSE MENU
← Cancel All →

and press **Enter/Pause**.

Cancel Batches?
No →

4. You can

- ◆ exit without canceling any batches. Press **Escape/Clear** or press → to display **No** and then press **Enter/Pause**. The printer returns to the Pause menu. Press ← or → to select another function from the Pause Menu, or to return to Print Mode and print all the batches.
- ◆ cancel all batches in the print queue. Press → to display **Yes**, then press **Enter/Pause**.

Cancel Format?
No →

Press ← or → then press **Enter/Pause**.

If password protection is enabled, you are prompted to enter a password before the formats, graphics, and fonts are deleted. Press **Feed/Cut** three times and then press **Enter/Pause**.

All formats are deleted. If you enter the wrong password, you return to the Main menu. For more information about password protection, see "Using Password Protection" in Chapter 10. If password protection is disabled, you will see

Cancel Graphic?
No →

Press ← or → then press **Enter/Pause**.

Cancel Font?
No →

Press →, then press Enter/Pause. You return to the Pause menu. If you select "Yes," these prompts delete ALL formats, graphics, and/or fonts in the printer.

5. Press ← or → to select another function from the Pause menu, or to return to Print mode.

Repeating a Batch

Before you start printing a new batch, you can reprint the last batch. The batch can be either the last one you printed completely or one that you canceled after starting to print.

1. From the Main Menu, press ← or → until you see

MAIN MENU ← Repeat Batch →

2. Press **Enter/Pause**.

Printing xxxx of xxx

The number increments until the entire batch has printed. When it is finished, you will see

PRINT MODE Ready

Offline Printing

Offline printing requires the optional keyboard, which must be purchased separately. Refer to your keyboard's *Operating Instructions* for more information about offline printing and batch entry.

Special Printing Considerations

Keep in mind the following special printing considerations.

Maximum Print Speed	Printing Method	Printhead Density	Knife	Peel Mode
2.5/4.0/6.0 ips (inches per second)	Thermal Direct Thermal Transfer	203/300 dpi dots per inch	Supported	Supported
8.0 ips	Thermal Direct Thermal Transfer	203/300 dpi	Not Supported	Supported
10.0 ips	Thermal Direct/Thermal Transfer	203 dpi only	Not Supported	Not Supported
12.0* ips	Thermal Direct/Thermal Transfer	203 dpi only	Not Supported	Not Supported

*12.0 ips is the high speed option, which must be purchased separately.

- ◆ The minimum label feed length is 0.75 inches (19 mm) using 8.0 ips or higher.
- ◆ 94x5 emulation is not supported using 300 dpi.
- ◆ The maximum supply and image length with the optional 300 dpi printhead is 12.0 inches (305 mm).
- ◆ You may need to clean the printhead and platen roller more frequently when printing at high speeds. See Chapter 9, "Care & Maintenance," for more information.

Printing TrueType® Fonts

TrueType® fonts are available on this printer. TrueType fonts are scalable and the characters print smoothly, without the jagged edges you see on bitmap fonts. When downloading a TrueType font, you download the entire font. You cannot specify a subset (particular characters or point size) of the font.

Note: These font files may be very large and image slower than bitmap fonts. The size of the font file, in bytes, is the minimum amount of memory you must have available for fonts in the printer's memory.

Your System Administrator may need to reconfigure the printer's memory to use downloaded TrueType fonts. Refer to the optional *Packet Reference Manual* (available on our Web site) to learn how to reconfigure the printer's memory. After reconfiguring memory, resend the font, format, and batch packets.

This printer can accept a TrueType font file that has been converted to Hex or Run-Length encoding using the version of Font Utility. Font Utility is available on our Web site (www.monarch.averydennison.com). Font Utility is a part of the Monarch MPCL Toolbox Utilities. You can also use a wide variety of Code Pages with International (Turkish, Latin, Spanish, etc.) characters. Using TrueType fonts allows you a greater range of fonts for your formats. TrueType fonts are designed to be regionally specific; therefore, all Code Pages may not be supported in a given font. Check with your System Administrator if you need to use TrueType fonts.

Licensing Your Fonts

We provide the Font Utility to help you create and download international code pages/characters. However, it is your responsibility to license the fonts you purchase and download to your printer. Contact your font supplier for licensing information.

Additional fonts that are compatible with this printer can be purchased from:

The Electronic Font Foundry; 11 Silwood Road; Ascot; SL5 OPY; England

(0)1344 875 201
www.eff.co.uk

This chapter tells you how to

- ◆ clear label jams and clean the printer.
- ◆ replace a printhead.

CAUTION: Do not use sharp objects to clean the printhead or touch the printhead with your fingers. This may damage the printer and require a service charge.

Clearing Label Jams

When you are printing and a jam occurs, the **Fault** light on the printer's front panel blinks. To clear the jam:

1. Turn off the printer and open the cover and printhead assembly.
2. If necessary, remove the label roll and ribbon.
3. Remove the jammed labels and reload the label roll.
4. Close the printhead assembly and turn on the printer.
5. Press **Feed/Cut** to position the supply under the printhead.

Cleaning

The rate and frequency at which you print determines how often you must clean the printer.

Note: You **must** clean the printhead as described below to maintain printhead life.

You may need to clean the printhead, sensor, and platen roller:

- ◆ if there is any adhesive build-up in the supply path.
- ◆ after printing approximately 3 rolls of thermal transfer/thermal direct supplies or after each ribbon.
- ◆ daily if your printer is in an excessively dirty, hot, or humid environment.
- ◆ when you see voids or streaking in the print as shown.



Voids



Streaks

When you are using higher speeds (with 203 or 300 dpi), and/or increased print contrast, we recommend cleaning the printhead after each ribbon with isopropyl alcohol. If you still notice build-up on the printhead or black streaks on your supply, order a printhead CLEAN-STRIP.

1. **Turn off the printer** and open the cover and printhead assembly.
2. Remove the label roll and ribbon (when cleaning the printhead).
3. Press down on the exit cover tabs to open the exit cover on the front of the printer.

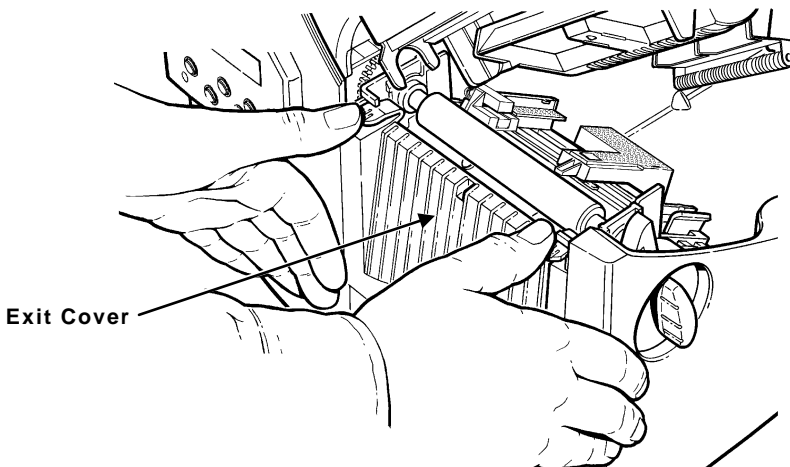

4. Clean the platen roller when you see significant adhesive build-up or a label is wrapped around the platen roller. Use a dry, soft-bristle brush, such as a toothbrush, to clean the standard (black) platen roller. If the brush does not remove all the adhesive
 - ◆ Use isopropyl alcohol ONLY on the standard (black) platen roller. Moisten a cotton swab with isopropyl alcohol and run the cotton swab across the platen roller. Turn the platen roller with your finger to make sure the platen roller is clean all the way around. After cleaning, feed several inches of supply through without printing to remove any remaining isopropyl alcohol.
5. Moisten a cotton swab with isopropyl alcohol. Rub the cotton swab across the peel bar and remove any build-up.
6. Moisten another cotton swab with isopropyl alcohol. Rub the cotton swab across the printhead and remove any build-up. You may need to use a printhead CLEAN-STRIP if the printhead is extremely dirty or you see streaks on the supply.

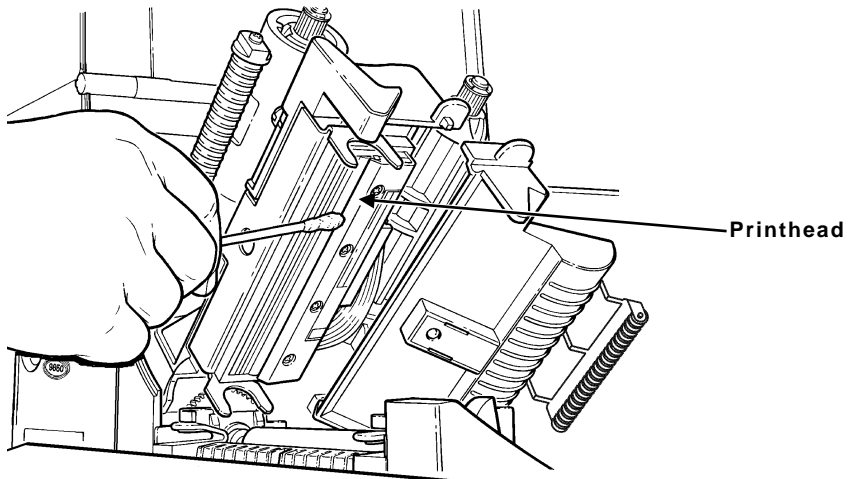

7. Rub the cotton swab across the supply sensor and die cut sensor and remove any build-up.

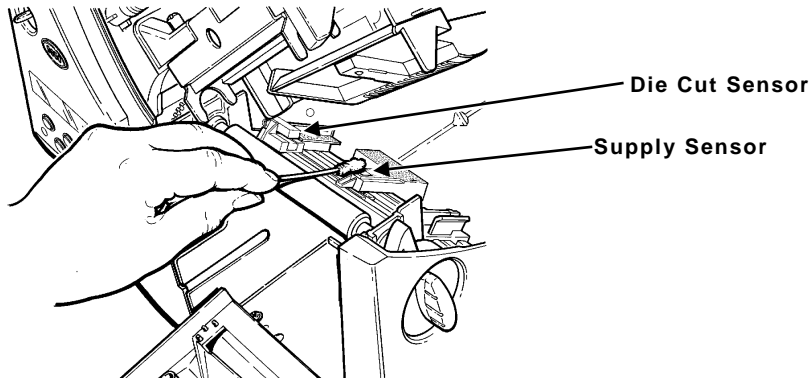

8. Clean the build-up in the supply path.
9. Let the printer dry before you reload supplies.
10. Close the exit cover by pushing firmly on it. Both latches will click into place.

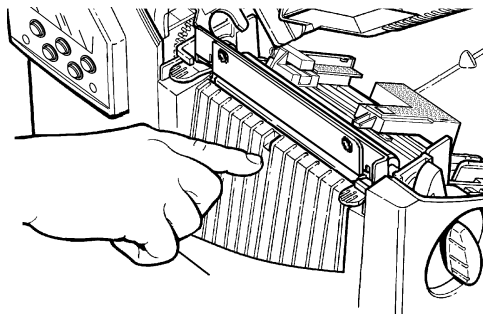

11. Close the cover and printhead assembly.
12. Turn on the printer.
13. Press **Feed/Cut** to position the supply under the printhead. Resend your format, batch, and check digit packets.

Replacing the Printhead

You may have to replace the printhead if it is damaged or worn-out. For example, you may see 616 (bad dot or dots) or 768 (printhead failure) error codes. See Appendix B, "Accessories & Options" for the printhead part number.

CAUTION: The printhead is sensitive to static electricity, which can damage the printhead or reduce its life. Ground yourself by touching some metal, such as the printer's metal base, before touching the printhead. Clean the printhead to remove any salt or oil left from handling prior to operation.

To replace the printhead:

1. **Turn off the printer.**
2. Open the cover.
3. Unlock the printhead by turning the retaining latch.
4. Press forward and down on the two latches on top of the printhead assembly as shown. The printhead drops down.

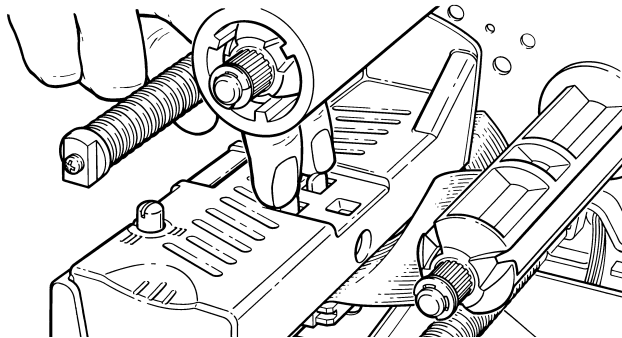

5. Lift the printhead assembly using the printhead tab and push back until the printhead assembly clicks into place.

6. Carefully unplug the cable from the printhead as shown. The printhead is sensitive to static electricity, which can damage the printhead or reduce its life. Ground yourself by touching some metal, such as the printer's metal base, before touching the printhead.

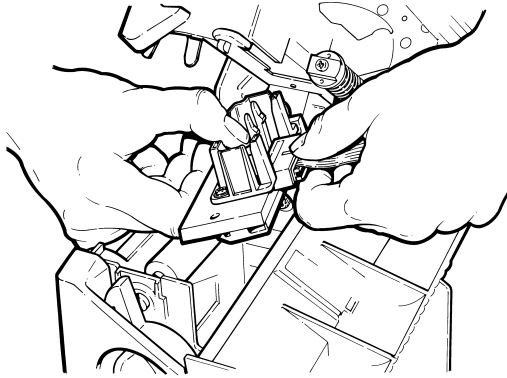

7. Carefully plug the cable into the new printhead.
8. Align the new printhead with the tabs.
9. Snap the printhead into place.

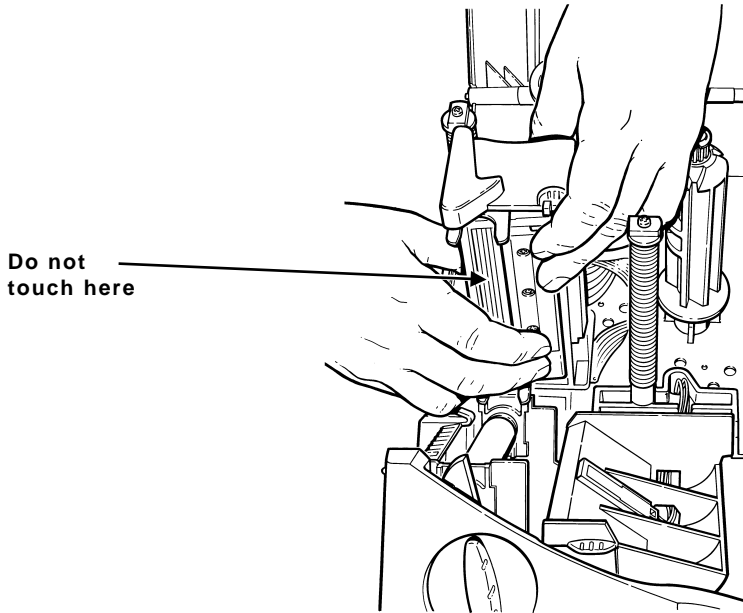

Note: Make sure the printhead cable does not touch the ribbon roll.

10. Clean the new printhead with a cotton swab dipped in isopropyl alcohol to remove any salt or oil left from handling.
11. Let the printhead dry and reload your supplies.
12. Close the printhead assembly and the cover. Turn on the printer.
13. Press **Feed/Cut** to position the supply under the printhead.

DIAGNOSTICS & TROUBLESHOOTING

This chapter explains how to perform simple diagnostic functions such as checking the software version, the supply quality, printing test labels, and using password protection. It also contains basic troubleshooting information.

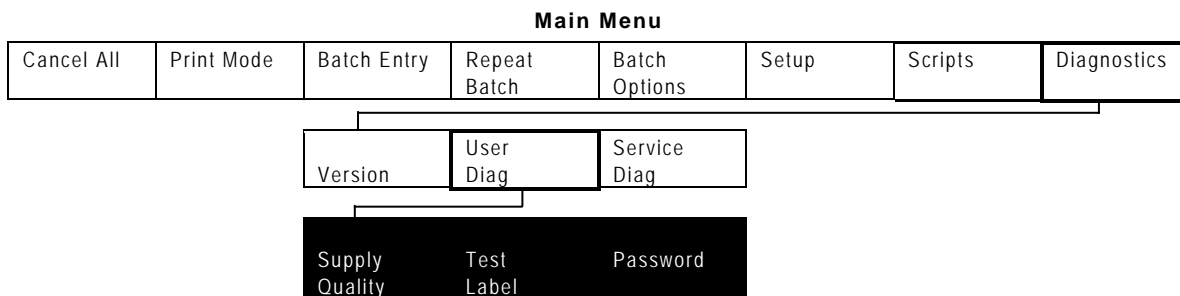

Factory Set Password

You need a password to access diagnostic functions. Press **Feed/Cut** three times and then press **Enter/Pause**.

Checking the Software Version

- From the Diagnostics Menu, press **←** or **→** until you see

DIAGNOSTICS Version →

- Press **Enter/Pause**. You will see

Model M9855 V 1.0

Line one lists the printer model number (M9855) and line two gives the version of software in the printer.

Printing a Test Label

1. From the Diagnostics Menu, press ← or → until you see

```
DIAGNOSTICS
← User Diag →
```

2. Press **Enter/Pause** and → until you see

```
USER DIAG
← Test Label
```

3. Press **Enter/Pause**. The following test labels print.



The first label shows the printer's configuration by packet (A-G). The second label shows the model number, software version, stock count, voltage, print contrast, printhead resistance, number of bad dots, and installed options. The test label also shows an inch count for the high energy ribbon. This information will help Technical Support diagnose the problem. Refer to the optional *Packet Reference Manual* for more information about the test label.

You can also print a test label by pressing ← and → at the same time. Hold for one second and release. If test labels do not print, call Technical Support.

Checking Supply Quality

The printer continuously stores data from the most recent 16 supplies printed to check the reflectivity of the sensor marks on the supply. Before you check your supply quality, print a batch of supplies or test labels.

1. From the Diagnostics menu, press ← or → until you see

```
DIAGNOSTICS
← User Diag   →
```

2. Press **Enter/Pause**. You will be at the User Diagnostics menu. Press ← or → until you see

```
USER DIAG
Supply Quality   →
```

3. Press **Enter/Pause**. If you have not printed any labels, the message "No data! Press Enter" appears. You will also see the "No data! Press Enter" message if you are using continuous (non-indexed) supplies. If you have printed labels since turning on the printer, you will see

```
Len  Min  Max  OK
← 1568 034 124 Y →
```

The Len listing is the length of the loaded supply in dots.

The Max listing should always be greater than the Min listing. The OK listing tells whether the sense mark on the supply passed a detection test. Press ← or → to see the other readings.

Using Password Protection

The password protection feature prevents formats, graphics or fonts from accidentally being deleted from the printer's memory. *It also limits access to the Setup and Scripts menus.*

Enabling the Password (System Administrators only)

A System Administrator can enable the password that must be entered before formats, graphics or fonts can be deleted.

1. From the Main Menu, press ← or → until you see

```
MAIN MENU
← Diagnostics
```

2. Press **Enter/Pause**. You will see

```
Enter Password
-----
```

3. Enter the password: press **Feed/Cut** three times and then press **Enter/Pause**.
If you enter the wrong password, you return to the Main Menu.

4. From the Diagnostics Menu, press ← or → until you see

```
DIAGNOSTICS
← User Diag
```

5. Press **Enter/Pause**. Then, press ← or → until you see

```
USER DIAG
← Password
```

6. Press **Enter/Pause**. You will see

```
Enable Password?
← No
```

The default for password protection is "No," so you will always see "No" even if passwords are enabled.

7. If you do not want the user to enter a password before they can delete formats, graphics, fonts, or access to the Setup and Scripts menus, press **Enter/Pause**. You return to the User Diagnostics Menu.

OR

Press **→** to display "Yes" and press **Enter/Pause**. The password protection is enabled for formats, graphics, fonts, and access to the Setup and Scripts menus. You return to the User Diagnostics Menu.

8. Press **Escape/Clear** twice to exit to the Main Menu.

Note: When password protection is enabled, a password is not required to clear batches, but it is needed to clear formats, graphics, and fonts.

Service Diagnostics

The Service Diagnostics menu can only be accessed by a Service Representative, because it requires a separate password. If you need to call Technical Support, print a test label first.

Troubleshooting

This section helps you correct some problems that may occur.

Problem	Action
Error message appears during startup.	Turn off the printer. Wait fifteen seconds and then turn on the printer. Call Technical Support if the error message reappears.
Does not print.	Check supply. Check ribbon. Send a corrected format and batch packet.
Does not feed.	Set wide/narrow knobs correctly.
Partially printed data.	Clean the printhead. Send a corrected format packet.
Printing shadows or smears.	Clean the printhead. Change supply. Check ribbon.
Light printing.	Change supply. Adjust the print contrast. Check wide/narrow knobs. Check ribbon.
Heavy printing.	Clean the printhead. Change supply. Adjust the print contrast. Check wide/narrow knobs. Check ribbon.
Voids in printing.	Clean the printhead. Change supply type. Check ribbon.
Serial bar codes do not print.	Leave printhead unlatched when not in use. Use a print speed of 2.5 IPS. Adjust the print contrast.

Problem	Action
Backing paper is wrapped around platen or peel roller.	Carefully remove the backing paper. Make sure the backing paper tears at the saw-toothed tear edge when using backfeed and peel mode.
Blank labels print or 750 series errors.	Clean supply sensors.
When downloading a script, the printer errors.	Check the available flash memory. Format flash memory or clear NVRAM.
After downloading a script, the script does not appear to be loaded.	Try formatting flash memory, then download the script again.

If you cannot fix a problem, call Technical Support.

Error Messages

You may receive the following types of error messages:

- ◆ Data Errors
- ◆ Communication Errors

Some errors numbered 400-438 and 500-574 are internal software errors. Errors numbered 900-999 are hard printer failures. If you cannot clear an error, turn off the printer, wait several seconds and then turn on the printer. For a complete list of errors, refer to the optional *Packet Reference Manual* available on our Web site. Call Technical Support if you need additional assistance.

Common Errors

Errors 001 to 405 and 429 to 435 are data errors. This type of error indicates that incorrect data was sent to the printer, and the printer is ignoring it. Your System Administrator should correct the packet and send it back to the printer.

Error	Description/Action
002	Name must be 1 to 8 characters (excluding non-printable control characters) inside quotes.
005	Supply width is invalid.
018	Code page selection defined in the field must be 0 (Internal), 1 (ANSI), 100 (Macintosh), 101 (Wingdings), 102 (UNICODE), 103 (BIG5 for UNICODE), 104 (GB2312 for UNICODE), 105 (SJIS for UNICODE), 106 (GB2312), 107 (BIG5), 437 (DOS Page 437), 850 (DOS Page 850), 852 (Latin 2), 855 (Russian), 857 (Turkish), 860 (Portuguese), 1250 (Latin 2), 1251 (Cyrillic), 1252 (Latin 1), 1253 (Greek), 1254 (Turkish), 1255 (Hebrew), 1256 (Arabic), 1257 (Baltic), or 1258 (Vietnamese).
025	Data length is too long.
101	Format referenced by batch not in memory.
400	Invalid character following {.
403	Field separator was not found.
409	Printer memory is full. Delete unnecessary formats or graphics from memory.
410	Parity mismatch.
411	Framing error (baud rate mismatch).
412	Flow control mismatch.
413	Online receive buffer is full. Check for a flow control problem.

- 611 Font, bar code, or density in the batch does not fit the format.
- 612 The data in this line of the batch is either missing or does not match the format.
- 613 Reference point off supply.
- 614 Portion of field off supply or there may be an invalid character in the packet.
- 703 The printer sensed a calibration of different-sized black marks. Make sure the correct supply type is loaded.
- 704 Printer has not sensed a supply mark within the specified number of inches or is out of supplies. Check the supply tracking, supply marks, black mark sensor position, and supply roll for binding. Press **Escape/Clear** and try to continue printing. Change supply.
- 750 Printhead is overheated. Turn off the printer.
- 751 Printer did not sense a black mark when expected. For errors 751-753, check the supply tracking, supply marks, black mark sensor position, and supply roll for binding. Press **Escape/Clear** and try to continue printing. Change supply.
- 752 Printer sensed a mark in the wrong place.
- 753 Printer sensed a mark that is too long.
- 754 Check for a ribbon jam or remove any slack in the ribbon by turning the take-up reel clockwise. Load a new ribbon.
- 755 Printhead is open. Close the printhead.
- 756 Load supplies.

- 757 Load supplies (supply length mismatch), because the calibrated supply length differs by plus or minus .25 inches from the format. Press **Feed/Cut**.
- 758 Either the supply is not seen or the on-demand sensor is broken. Check for a label jam, clear the supply path, or reload supplies. This error may occur if you remove a label too quickly in the on-demand mode.
- 762 Low Voltage. For DC-powered printers, recharge the external battery. For AC-powered printers, check the power inlet where the printer is connected. The acceptable voltage range is between 90-132 V_{RMS} and 180-264 V_{RMS}. If more or less power is received, unpredictable results may occur.
- 763 Waiting to dispense label. Press **Feed/Cut**.
- 764 Verifier scan error (bad scan) on label when using normal (no overstrike) mode. Press **Escape/Clear** to clear the error and continue printing. The printer recalibrates (feeds a blank label) after this error.
- 765 The printhead has less than 8 bad dots. The printer can shift bar code fields to avoid bad dots. You may need to press **Escape/Clear** to continue printing. Print a test label to confirm the number of bad dots.
- 768 Printhead has more than 8 bad dots within the format area or is not connected. Connect the printhead.
- 772 Verifier scan error (bad scan) on label or multiple labels in a row when using overstrike and continue mode. The verifier detected three or more bad scans in a row. Press **Escape/Clear** to clear the error and continue printing. The printer recalibrates (feeds a blank label) after this error.
- 773 Verifier failure. The verifier is enabled, but not connected. Make sure the I/O cable and/or serial cable is connected to the verifier. Refer to your verifier's *Operating Instructions* for more information.
- 791 The printer has an error pending. Turn off the printer. Wait 15 seconds (until the power light is completely dim) and turn it back on. Resend the packets.

SPECIFICATIONS

A

Printer

Height:	12.5 inches (318 mm)
Width:	12 inches (305 mm)
Depth:	13 inches (330 mm)
with the optional metal cover (H x W x D)	13.0" (330 mm) x 12.5" (318 mm) x 17.3" (439 mm)
Weight:	21 lb. (9.5 kg)
Weight w/metal cover:	29 lb. (13.2 kg)
Shipping Weight:	25 lb. (11.4 kg)
Shipping Weight w/metal cover:	34 lb. (15.5 kg)
Power Source:	90-132V _{AC} with autoselect 50/60Hz 180-264V _{AC} with autoselect 50/60Hz
Operating Limits:	For Thermal Transfer (ribbon) 40° to 95°F (4° to 35°C) For Thermal Direct 40° to 104°F (4° to 40°C) Storage: 15°F to 120°F (-9°C to 49°C) Humidity: 5% to 90% non-condensing
Printhead:	Thermal at 4 inches (102 mm) wide 203 dpi (8.0 dots per mm) OR 300 dpi (11.8 dots per mm) This option must be purchased separately.

Printing Method:	Thermal Transfer (ribbon) or Thermal Direct
Print Speed:	2.5 ips (64 mm) default for all serial bar codes, 4.0 ips (102 mm), 6.0 ips (152 mm) default for parallel bar codes, 8.0 ips (203 mm), and 10.0 ips (254 mm). 12.0 ips (305 mm) printing is an option that must be purchased separately. See Chapter 8, "Printing" for special considerations when printing at speeds greater than 6.0 ips.
Maximum Print Area:	4.0 inches x 16.0 inches (102 mm x 406 mm) with 203 dpi 4.0 inches x 13.0 inches (102 mm x 330 mm) with 300 dpi

Tag Cut Dimensions

Use these specifications for the 926™ Knife.

Widths:	0.75 inches to 4.0 inches (19 mm to 102 mm)
Lengths:	1.2 inches to 16.0 inches (30 mm to 406 mm) Note: The maximum cut tag length using the stacker is 3.66 inches (93 mm).
Thickness:	7 mils to 10 mils
Cut Angle:	5 degrees (plus or minus) from 90 degrees with respect to the edge.
Batch Separator:	3.66 inches (93 mm)

Supplies

For high temperature or high humidity environments, contact us for supply recommendations. Continuous (non-indexed) supply does not have perforations or black marks and must be used in continuous mode. We recommend using continuous supply with a tear bar or the optional knife. If you purchased the optional knife, you cannot use the tear bar. Aperture supplies are tags or labels with holes (or openings) in them. The supply is sensed using the holes. The holes can be only on the edge or in the center of the supply.

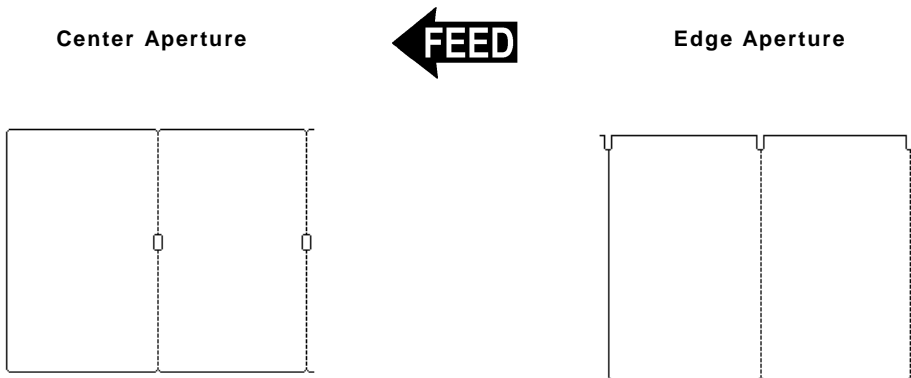

- | | |
|-------------------------|---|
| Supply Types: | Thermal Transfer or Direct |
| Supply Widths: | 0.75 inches (19 mm) minimum
4.25 inches (108 mm) maximum |
| Supply Lengths: | 0.32 inch (8 mm) minimum
0.75 inch (19 mm) minimum for tags
1.2 inches (30 mm) minimum for cutting tags
17.5 inches (445 mm) maximum |
| Total Thickness: | 7 to 12 mils
7 to 10 mils with the optional knife |

String Tag Supplies

Widths:	0.90 inches (23 mm) minimum 2.0 inches (51 mm) maximum
Lengths:	0.78 inch (20 mm) minimum 1.78 inches (45 mm) maximum
Thickness:	5.5 to 16 mils
String Loop Length:	1.5 inches (38 mm) maximum
String Orientation:	Facing operator
Wind Direction:	Face out
Max. Roll Diameter:	9.375 inches (238 mm)
Supply Core:	3.0 inches (76 mm) or 4.0 inches (102 mm) 4.0 inches is recommended.

Ribbon Specification

Do not leave ribbon in sunlight, high temperatures or humidity.

Ribbon Type: Standard or High Energy

Ribbon Widths	Use with Max. supply width
1.5 inches (38 mm)	1.3 inches (33 mm)
1.8 inches (46 mm)	1.5 inches (38 mm)
2.3 inches (58 mm) standard or high energy	2.0 inches (51 mm)
3.3 inches (84 mm)	3.0 inches (76 mm)
4.3 inches (110 mm) standard or high energy	4.0 inches (102 mm)

Ribbon Length: 23,600 inches (600 meters)

About Ribbons

The width of the ribbon must be greater than the supply width. Since some supplies are more abrasive to printheads than others, using a ribbon wider than your supply helps protect the printhead. Replacement printheads are expensive.

Cable Pinouts

The following tables show the connector pins for a 9-pin to 25-pin (119806) cable or a 25-pin to 25-pin cable (126826).

9-Pin (F)	To	25-Pin (M)
CD 1		20 DTR
RD 2		2 TD
TD 3		3 RD
DTR 4		8 CD
SGND 5		7 SGND
DSR 6		6 DSR
RTS 7		4 RTS
CTS 8		5 CTS
N/C 9		1 Shield Drain Wire

25-Pin (F)	To	25-Pin (M)
FG 1		1 FS
TD 2		2 TD
RD 3		3 RD
RTS 4		4 RTS
CTS 5		5 CTS
DSR 6		6 DSR
SG 7		7 SG
CD 8		8 CD
N/C 20		20 DTR

ACCESSORIES & OPTIONS

B

Accessories

- ◆ 926™ Knife
- ◆ 927™ Catch Tray
- ◆ 928™ Stacker
- ◆ 935™ Rewind
- ◆ 938™ Verifier (Can not be used with 926 Knife)
- ◆ 939™ Keyboard or 939i™ Keyboard
- ◆ 945™ Unwinder
- ◆ Replacement Printhead Kits:
 - 12678301 203 dpi
 - 12678401 300 dpi
- ◆ High Energy Supplies (TUFFMARK®)
- ◆ Ribbon Take-Up Core (11796120, 30, or 40; available in 2", 3", or 4" widths)
- ◆ Monarch® MPCL™ Toolbox (utilities to configure the printer, download fonts, and design formats) available on our Web site.
- ◆ Printhead CLEAN-STRIP (120350)
- ◆ Printhead Cleaning Pen (114226)
- ◆ Cables: 9-pin to 25-pin (119806), 25-pin to 25-pin (126826)

Note: You can use either the optional knife or peel mode, but not both.

Packaging Materials

Use the following part numbers to order the appropriate packaging materials should you need to ship the printer to a different location.

Plastic Cover Printers	Description and Qty.	Metal Cover Printers	Description and Qty.
00065501	Carton (1)	00066101	Carton (1)
00065502	Corrugated Pad (1)	00066102	Foam Pad Set (1)
00065503	Corrugated Pad (1)	00066105	Corrugated Pad (1)
00065507	Foam Pad Set (1)		

Factory-Installed Options

- ◆ 7411™ Print Server for 802.11b wireless networks (also supports wired Ethernet printing).
- ◆ 300 dpi printhead (12678401)
- ◆ Peel mode with on-demand sensor
- ◆ Tear Bar
- ◆ Metal Cover
- ◆ Knife-ready (order Knife separately)

Ethernet Information

We offer internal and external Ethernet connectivity solutions. These solutions make it easy to set up, manage, and monitor a printer linked to an Ethernet connection. The print server provides multiprotocol capabilities for users with Windows® 95/98/2000 or Windows NT®, TCP/IP, and NetWare®. Software is available on our Web site to configure the print server. It can also be configured using HP Jet Admin™ or HP Web JetAdmin™ software.

Configuration information prints automatically if the Ethernet print server senses a hardware error. To print configuration information on demand, press the *Test* button on the side of the external Ethernet print server unit or use the configuration utility provided for your network operating system. The configuration label prints in MPCL format.

Note: The configuration label is best displayed using 4" wide by 6" long labels. If the label is too small, some information may print outside the label edges.

RF Information

We offer the 7411 Print Server that communicates with printers on an 802.11b wireless network. You can use the print server in ad-hoc (peer-to-peer) or infrastructure (access point) wireless mode. In addition, the wireless print server includes a unique dual-mode built-in wired Ethernet connection. You can switch between wired and wireless mode without any loss of data.

MENU STRUCTURE



Press **Escape/Clear** to see the Main Menu. Use **←** or **→** to scroll through options. Press **Enter/Pause** when you see the menu option you need.

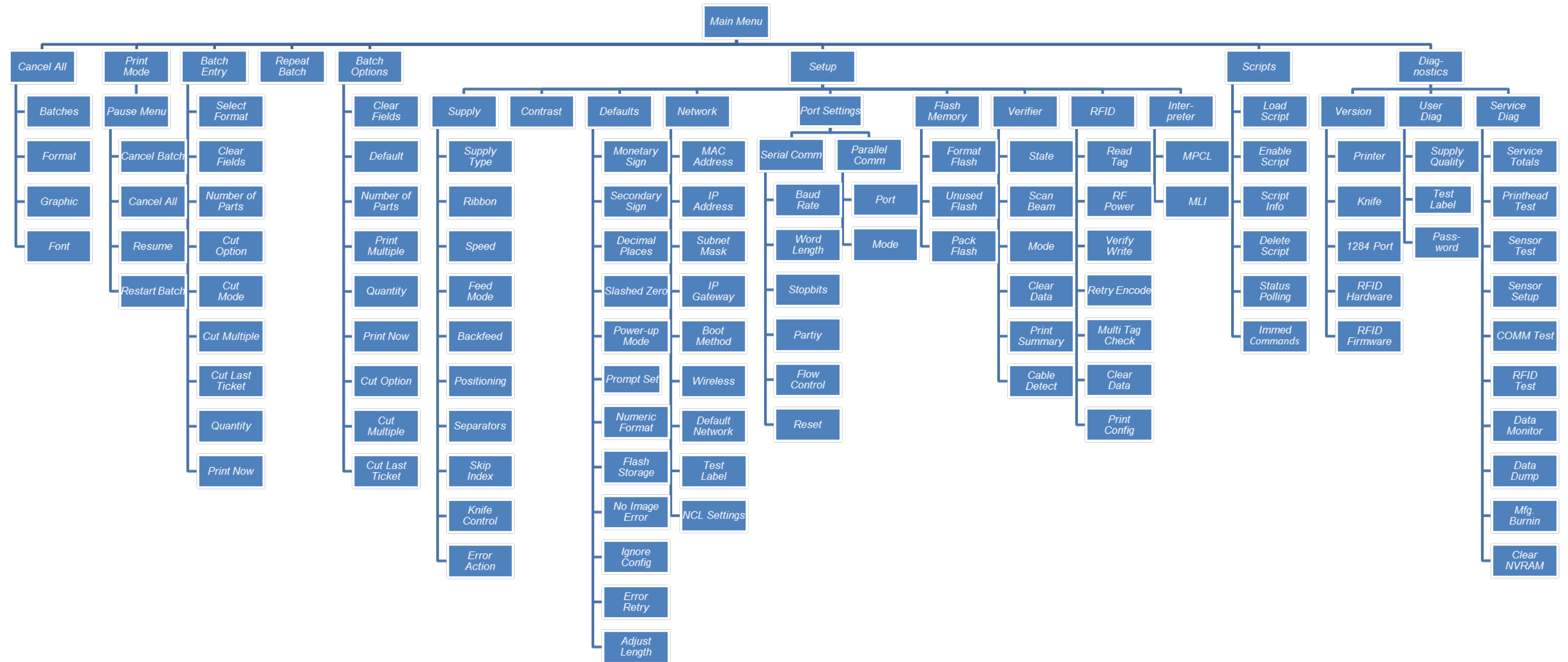

GLOSSARY



The following terms will help you use this manual.

continuous mode	Mode in which the printer prints all the labels in the batch without stopping.
download (send)	Transmission of data from the host to your printer.
format	Supply layout or design, which the <i>System Administrator</i> downloads as a format packet to your printer.
host	Any mainframe, minicomputer, data collect terminal, or personal computer sending data to the printer.
LCD	Display on the printer used to indicate printer conditions and problems.
leader	Wrap around a new roll of ribbon with printing on it.
on-demand mode	Mode in which the printer stops after each label to allow you to remove it.
print job (batch)	Actual data printed on a label or tag. The host may download the print job together with the format, or as a separate packet. The print job is also called a "batch."
online	Direct communication between a computer and the printer.
Supply Sensor	Senses whether supply is loaded or needs to be loaded in the printer. Located in the supply path.
Supplies	Labels used for printing.
System Administrator	Person responsible for creating and downloading packets.

INDEX

A

about fonts 8-8
accessories B-1
adjusting
 backfeed distance 4-14
 cut position 4-12
 dispense position 4-13
 margin position 4-11
 print position 4-8
 supply position 4-10
 supply width 2-12

B

backfeed 4-7
batch
 repeating 8-6
 restarting 8-3
baud rate
 options 5-2
baud rate 5-1

C

cancel
 paused batch 8-4
checking
 print 10-2
 software 10-1
cleaning printer 9-1
clearing jams 9-1
common
 errors 10-8
communication
 errors 10-7
communication parameters
 baud rate 5-1
 parity 5-1
 start (XON) character 5-1
 stop (XOFF) character 5-1
 stop bits 5-1

word length 5-1
communications
 parallel 5-5
contrast
 setting 4-20
currency 6-3
cut
 position 4-12

D

default
 port settings 5-1, 5-5
 values 5-1, 5-5
dispense
 position 4-13
distance
 backfeed 4-14
documentation
 ordering 1-4

E

emulating 9445 1-4
error label
 printing 8-2
errors
 common 10-8
 communication 10-7
 summary 10-7
Ethernet B-3
exiting an option 1-8

F

flash
 memory 6-8
flow control
 options 5-4
function
 selecting 1-7

H

high energy ribbon 3-4

I

IEEE-1284 5-5

information

printing 8-7

RF B-3

Information

Ethernet B-3

J

jams

clearing 9-1

L

label

specifications A-3

labels

adjusting for width 2-12

clearing jams 9-1

test 10-2

loading

ribbon 3-2

M

maintenance

cleaning printer 9-1

margin

adjusting 4-11

memory

flash 6-8

mode

offline 8-6

monetary sign

defining 6-3

O

offline mode 8-6

on-demand printing 8-2

option

selecting 1-7

options

baud rate 5-2

flow control 5-4

parity 5-3

options B-1

P

parallel 5-5

communications 5-5

parallel communication 5-6

parity

options 5-3

parity 5-1

passwords

setting 10-1

paused batch

cancel 8-4

port settings 5-1, 5-5

print

adjusting position 4-8

offline mode 8-6

setting contrast 4-20

print speed 4-5

printer

9445 emulation 1-4

buttons 1-6

checking status 1-6

cleaning 9-1

defaults 4-5, 4-7, 4-16, 6-3, 6-8

establishing communication 1-5

features 1-1

lights 1-6

operating specifications .. A-1

physical specifications A-1

unpacking 1-3

printer accessories B-1

printer options B-2

printhead replacement 9-5

printing

on-demand 8-2

printing

error label 8-2

printing

considerations 8-7

printing

information..... 8-7
printing
True Type fonts..... 8-8

R

radio frequency 0-3
ribbon
high energy..... 3-4
loading 3-2
specifications A-5
supply options..... 4-4

S

selecting a function..... 1-7
separators
supply options.....4-15
setting
communication parameters5-1
contrast4-20
print contrast.....4-20
skip
index4-16
software10-1
specifications
operating A-1
physical A-1
ribbon A-5
string tag A-4
supplies A-3
start (XON) character..... 5-1
stop (XOFF) character 5-1
stop bits..... 5-1
string tag
specifications A-4
string tags
supply.....2-10
supply
adjusting position4-10
adjusting print options 4-8
options 4-3, 4-6, 4-16
position.....4-10
print options4-10, 4-12, 4-13, 4-14
string tags.....2-10
supply options
ribbon 4-4

separators4-15

T

tag specifications A-3
tear bar.....2-9
tear edge2-8
test.....10-2
troubleshooting10-6
True Type fonts
printing.....8-8

V

values
communication5-1, 5-5
default5-1, 5-5
version10-1

W

word length
options5-2
word length5-1



028028

Avery Dennison
170 Monarch Lane
Miamisburg, OH 45342

1-800-543-6650 (In the U.S.A.)
1-800-387-4740 (In Canada)
www.monarch.averydennison.com

