

# MONARCH<sup>®</sup> 9493<sup>™</sup> VEHICLE MOUNT INSTRUCTIONS

Using the vehicle mount, you can attach your Monarch<sup>®</sup> Sierra Sport4<sup>™</sup> 9493<sup>™</sup> printer to a forklift or other vehicle. This document describes how to install and use the vehicle mount with the printer.

Information in this document supercedes information in previous versions. Refer to our Web site ([www.monarch.com](http://www.monarch.com)) for the latest documentation and release information.

## Installing the Battery

---

The printer has a battery for power; however, it uses the vehicle's battery to keep the printer's battery charged. The input voltage range is 13-48V.

Refer to the printer's *Operator's Handbook* for important battery information.

1. Turn off the printer when you change batteries.
2. Lay the printer down so the back of the printer faces up.
3. Remove the plastic from a new battery. Slide the battery into the battery well in the bottom of the printer until it latches into place.

# Connecting Communications Cables

---

The printer uses either 9-pin serial communications or USB communications. For best results, use only Monarch® cables. Refer to the *Operator's Handbook* for more cable information.

1. Open the hinged cable door on the side of the printer by loosening the two screws with a Phillips screwdriver.
2. Plug the DB9 connector into the DB9 serial port, or plug the type A or mini-B USB connector into the appropriate USB port.
3. Place the cable in one of the cable cavities.
4. Close the cable door and tighten the screws.

# Installing the Mount

---

Only qualified personnel should install the vehicle mount, using one of the three supported mounting positions shown in these instructions. The mount is 9.5 inches (240 mm) wide and 7.5 inches (187.5 mm) long.

Following is a list of the mounting hardware included with the vehicle mount:

- ◆ four M6 x 60 2 3/8-inch screws (3/16-inch hex)
- ◆ four lock washers
- ◆ one mounting plate
- ◆ two aluminum strap buttons
- ◆ one M3 allen wrench

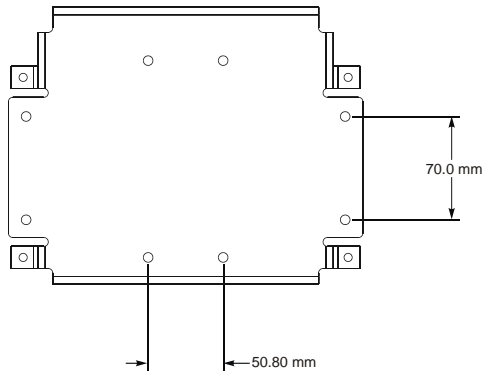

**Overhead view of mount showing location and spacing of mounting holes.**

## Replacing the Fuse

---

The vehicle mount uses an NRTL listed 10-amp, 250-volt fast blow fuse (order part 128022). The fuse is located on the cable on the right side of the vehicle mount.

To replace it:

1. Push in and twist the fuse holder counterclockwise to open it.
2. Remove the fuse.
3. Insert a new fuse of equal rating. The replacement fuse must have a DC voltage rating of at least 250 volts.
4. Place the two halves of the fuse holder together and push in and twist clockwise to tighten it.

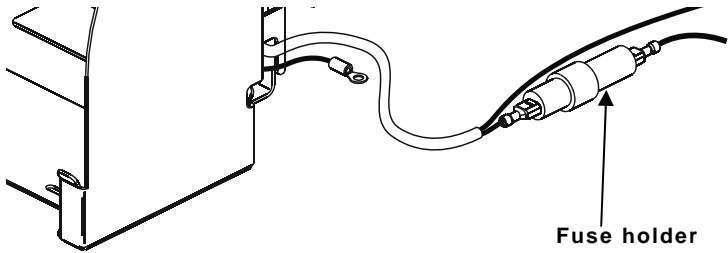

5. Plug the battery charging cable into the battery socket on the back of the printer.

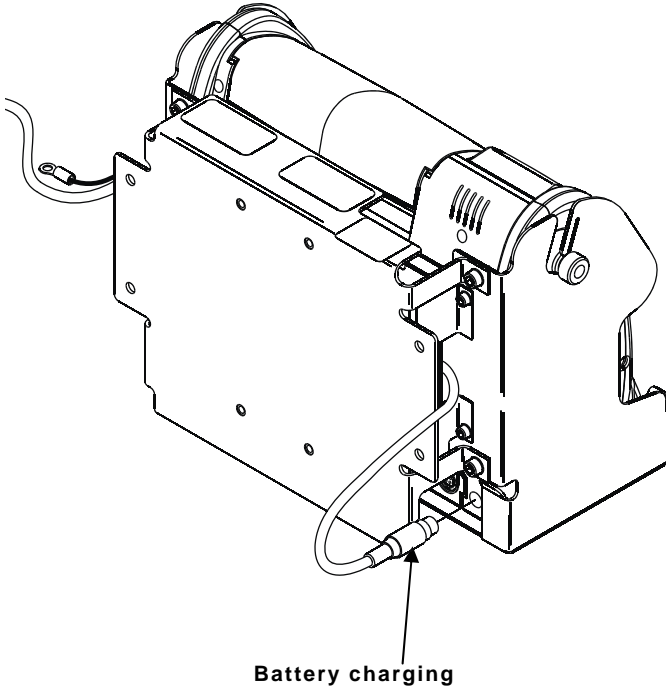

## Reading the LEDs

---

Three LEDs on the vehicle mount indicate the following activity:

LED Indicators		Status
Blue	on	power is on
	off	power is off
Green	off	no battery
	one blink	battery pre-charge
	two blinks	battery is charging
	three blinks	usable battery (80% capacity)
Amber	on	battery charging is complete
	blinking	error (call Service)

## Installing Overhead (Recommended)

1. Select a suitable location for the mount inside your vehicle.
2. If using the mounting plate, center the mounting plate on your vehicle's overhead rails.
3. Align the four holes in the vehicle mount with the holes in the mounting plate.
4. Use the four mounting screws and lock washers to attach the vehicle mount to your vehicle.
5. Wire the printer to your vehicle as needed. See "Electrical Specifications" for input information.

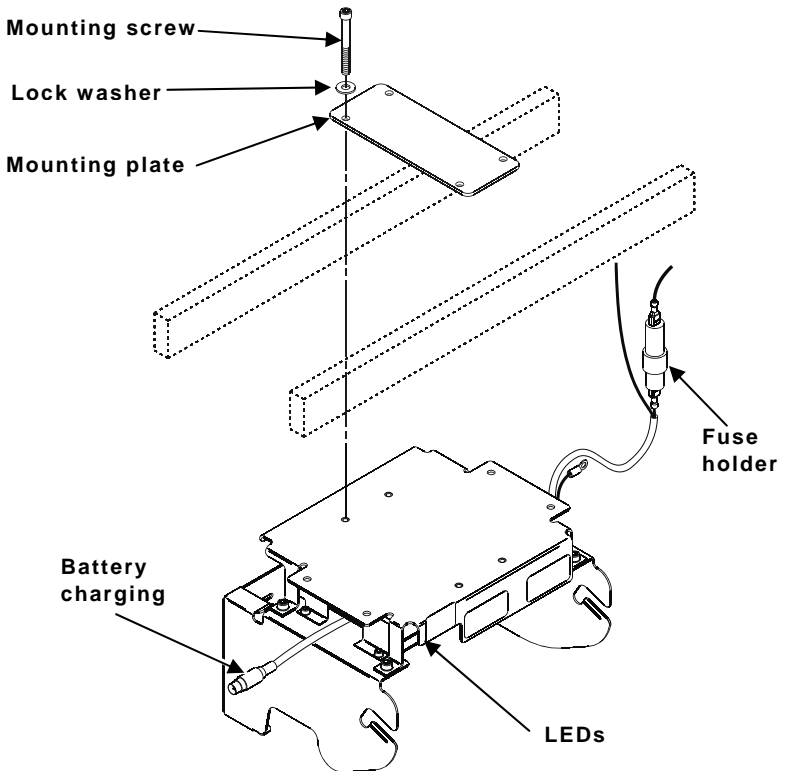

## Installing Vertically or on a Tabletop

1. Select a suitable location for the mount inside your vehicle.
2. If using the mounting plate, align the four holes in the vehicle mount with the holes in the mounting plate.
3. Use the four mounting screws and lock washers to attach the vehicle mount to your vehicle.
4. Wire the printer to your vehicle as needed. See “Electrical Specifications” for input information.

**Note:** If you install the vehicle mount on a tabletop, you need to rotate the display. Refer to the printer’s *Operator’s Handbook* for more information.

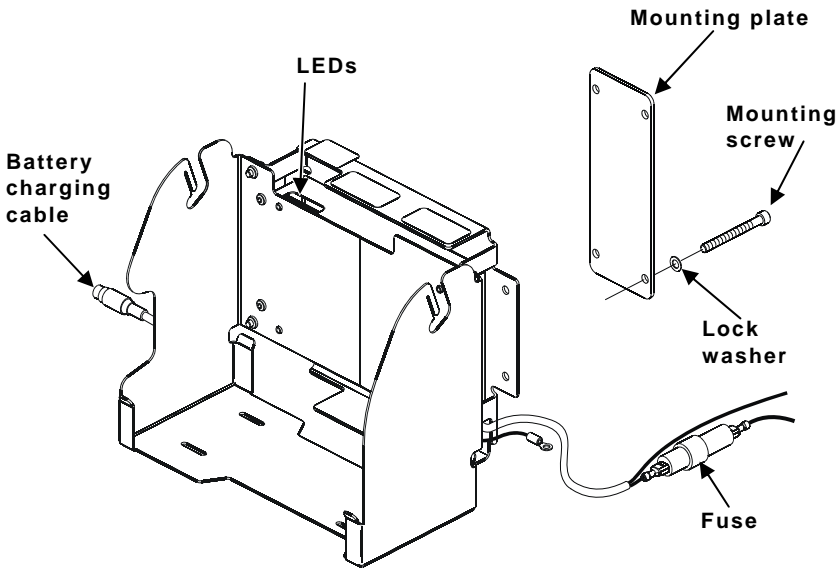

Vertical mounting position

## Routing Electrical Cables

---

Only qualified personnel should install the vehicle mount. When wiring the mount to your vehicle make sure you observe the following safety guidelines:

- ◆ Establish a route for the cables that is clear of any moving parts or hot surfaces.
- ◆ Use cable ties to fix the mount cables to existing cables in your vehicle.
- ◆ Use the proper gland when the cable must go through a panel.
- ◆ Make sure the cable does not have any tight bends. The minimum recommended radius is 2.5 inches (63.5 mm).
- ◆ Make sure the cables do not swing or rub against the vehicle. Use cable ties approximately every 12 inches (305 mm) so the cables do not flex.
- ◆ **Do not** wind a cable through the mesh on a cage. Route all cables *inside* the forklift.
- ◆ On electric vehicles, take power from as close to the battery as possible, but not directly from the battery and not before a main fuse.
- ◆ On gasoline, diesel, or propane vehicles, take power from as close to the battery terminals as possible. **Do not** use existing wiring.
- ◆ Connect the cables at the battery with an inline fuse holder. Cables should be connected within 8-inches of the positive terminal.
- ◆ All fuses should be as close to the power source as possible.
- ◆ When routing, make sure the fuse remains easy to access for replacement.
- ◆ **Do not** cut, splice, or otherwise rearrange your vehicle's wiring or components.
- ◆ **Do not** use solder connections.

# Wiring the Mount to Your Vehicle

---

**Vehicle battery version only.** Follow these steps to wire the mount to the vehicle's battery.

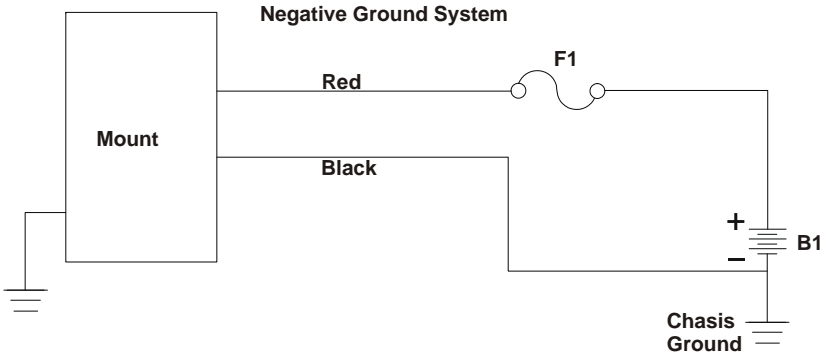

1. Connect the fuse holder (F1) on the positive side and within 18 inches (457 mm) of the battery (B1) post connection.
2. Connect the vehicle mount's red or white wire to the positive battery post.
3. Connect the vehicle mount's black wire to the negative battery post.



## Attaching the Printer

---

To attach the printer on the vehicle mount:

1. Use the M3 allen wrench to remove the plastic strap buttons on each side of the printer and replace them with the aluminum buttons included with the vehicle mount hardware.
2. Make sure the printer's battery and communication cable are installed.
3. Insert the printer into the slots on the vehicle mount using the strap buttons as a guide.

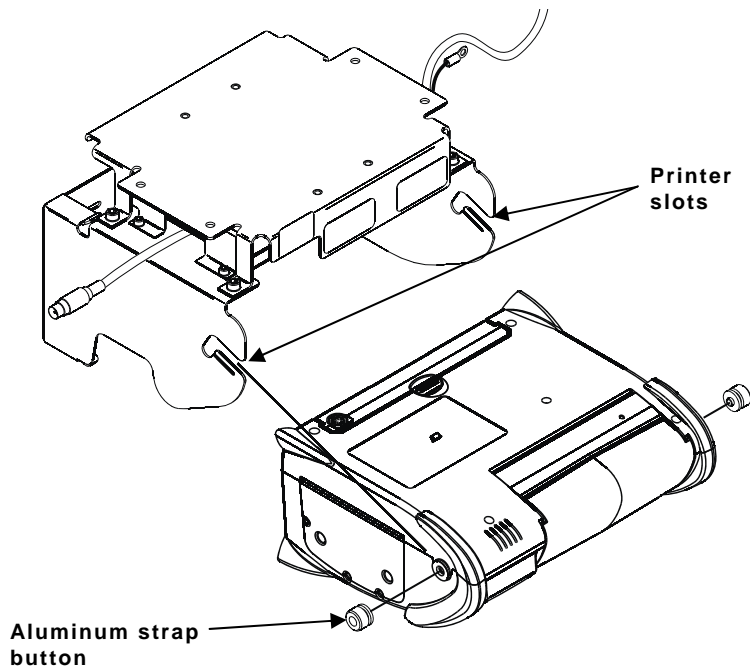

4. Push down firmly on the printer so it locks completely in place

## Printing

---

Refer to the printer's documentation for information on loading supplies and printing.

## Using the External Supply Holder

---

Use the optional external supply holder with larger supply rolls. Feed the supply through the printer using the fan-fold supply slot. Refer to the printer's documentation for more information on loading supplies.

### Installing the External Supply Holder

Following is a list of the mounting hardware included with the supply holder:

- ◆ four M5 hex nuts
- ◆ four star lock washers
- ◆ one mounting plate

To attach the supply holder to the vehicle mount:

1. Remove the printer from the vehicle mount, if attached.
2. Remove the mounting plate from the supply holder by removing the four nuts and lock washers.
3. Insert the posts in the mounting plate into the four slots in the bottom of the vehicle mount. The mounting plate goes on the "inside" of the vehicle mount.

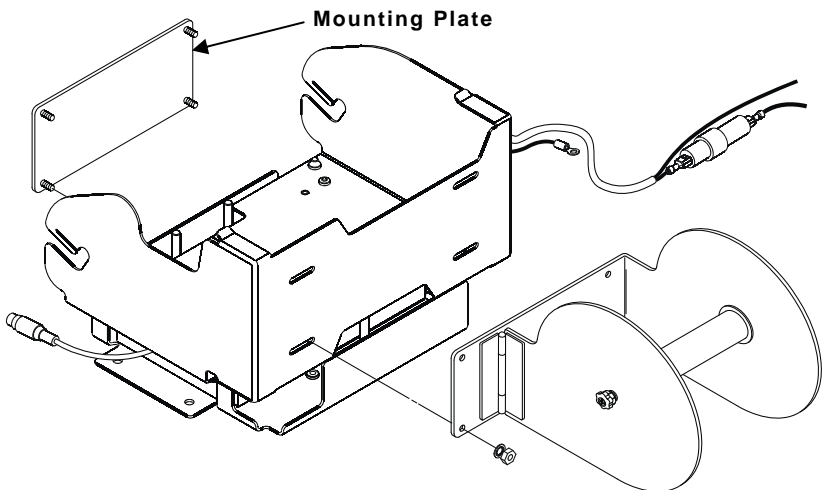

4. Align the holes in the supply holder with the posts on the mounting plate. The supply holder goes on the “outside” of the vehicle mount.
5. Replace the four lock washers and nuts to fasten the supply holder in place.
6. Attach the printer. See “Attaching the Printer” for more information.

## **Loading Supply on the External Supply Holder**

The external supply holder can hold up to a 5-inch (127 mm) maximum outer-diameter supply roll.

To load supply on the supply holder:

1. Open the supply holder. Unscrew the knob on the side of the holder and pull it open.

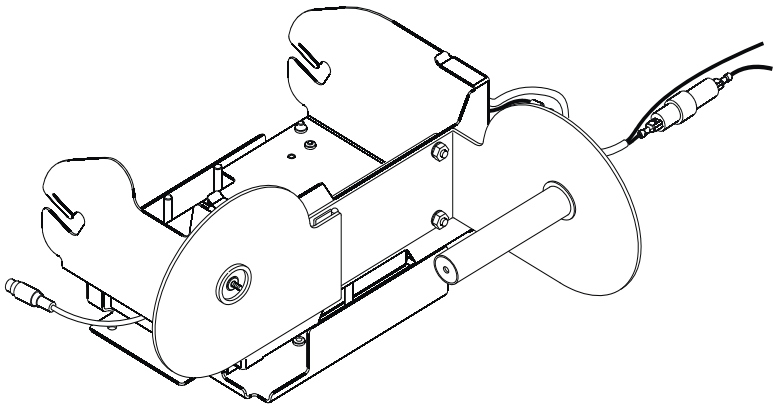

2. Remove the tape from a new roll of supply.
3. Insert the supply roll onto the supply holder so it unrolls from the bottom.
4. Close the side of the holder and tighten the knob.
5. Load supply in fan-fold mode. Refer to the printer’s documentation for more information.

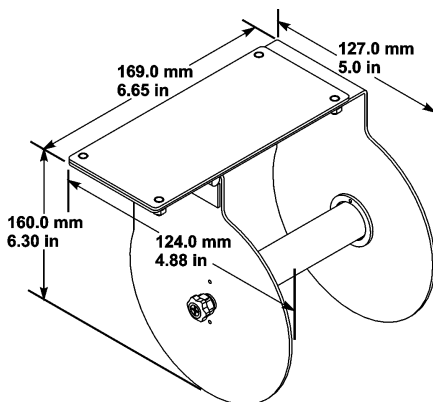

## Electrical Specifications

---

Output is electrically isolated from the input. Output common is not connected to the forklift module chassis. It can be jumpered internally to the chassis. Call Service for more information.

For printer specifications, refer to the *Operator's Handbook*.

### Supported Input Voltages

13V, 24V, 36V, 48V

### Input Power

- ◆ 50 watts max at 13 volts
- ◆ 36 watts max at 24 to 48 volts

### Input Current

To determine the input current, divide the input power (watts) by the input voltage.

### Input Voltage Range

The printer accommodates 13-48 volt systems. The input is transient protected.

### Operating Temperature

- ◆ 32-104°F (0-40°C)
- ◆ 0-95% humidity (non-condensing)