

System Administrator's Guide

Monarch[®] 9460[™] Printer

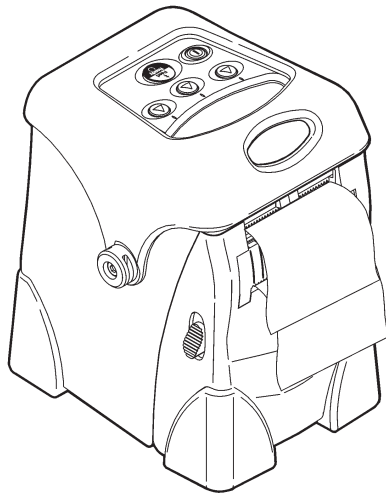

Each product and program carries a respective written warranty, the only warranty on which the customer can rely. Paxar reserves the right to make changes in the product, the programs, and their availability at any time and without notice. Although Paxar has made every effort to provide complete and accurate information in this manual, Paxar shall not be liable for any omissions or inaccuracies. Any update will be incorporated in a later edition of this manual.

© 2006 Paxar Americas, Inc. a subsidiary of Avery Dennison Corp. All rights reserved. No part of this publication may be reproduced, transmitted, stored in a retrieval system, or translated into any language in any form by any means, without the prior written permission of Paxar Americas, Inc.

WARNING

This equipment has been tested and found to comply with the limits for a Class B digital device, pursuant to Part 15 of the FCC Rules. These limits are designed to provide reasonable protection against harmful interference when the equipment is operated in a commercial environment. This equipment generates, uses, and can radiate radio frequency energy and, if not installed and used in accordance with the instruction manual, may cause harmful interference to radio communications. Operation of this equipment in a residential area is likely to cause harmful interference in which case the user will be required to correct the interference at his own expense.

RF Operation is subject to the following two conditions: (1) this device may not cause interference, and (2) this device must accept any interference including interference that may cause undesired operation of the device.

CANADIAN D.O.C. WARNING

This digital apparatus does not exceed the Class B limits for radio noise emissions from digital apparatus set out in the Radio Interference Regulations of the Canadian Department of Communications.

Le présent appareil numérique n'émet pas de bruits radioélectriques dépassant les limites applicables aux appareils numériques de la classe B prescrites dans le Règlement sur le brouillage radioélectrique édicte par le ministère des Communications du Canada.

Trademarks

9433, 9462, 9465, Monarch®, MPCL, and Sierra Sport are trademarks of Paxar Americas, Inc.

The Bluetooth® trademarks are owned by Bluetooth SIG, Inc.

Paxar® is a trademark of Paxar Corporation.

Avery Dennison® is a trademark of Avery Dennison Corporation.

Adobe and Acrobat are registered trademarks of Adobe Systems Incorporated.



Avery Dennison Printer Systems Division
170 Monarch Lane
Miamisburg, Ohio 45342

TABLE OF CONTENTS

INTRODUCTION	1-1
Using This Manual.....	1-1
Audience	1-1
Using the Menu Charts	1-2
Using the Display and Buttons.....	1-2
Selecting an Option	1-3
Exiting an Option.....	1-3
Printing	1-4
Selecting a Language	1-5
USING DIAGNOSTICS	2-1
Diagnostics.....	2-1
Printer	2-3
Test Label.....	2-3
Sensors	2-6
Printhead	2-8
Battery.....	2-9
View Totals	2-9
Display	2-10
Keyboard	2-11
Communications	2-12
RAM	2-13
Data Dump.....	2-14
About	2-15
Online Diagnostics	2-15
Service Diagnostics	2-16
File System.....	2-16

SETTING UP THE PRINTER	3-1
Stock Energy	3-3
Backlight	3-4
LCD Contrast	3-5
Printer	3-6
Adjusting the Print Contrast.....	3-7
Adjusting the Supply Position	3-8
Adjusting the Print Position	3-9
Setting the Margin Adjust	3-10
Setting the Demand Sensor.....	3-11
Setting the Stock Sensor.....	3-14
Selecting the Die Cut Sensor.....	3-15
Selecting the Black Mark Sensor	3-16
Selecting the Non-Indexed Sensor	3-18
Selecting the Aperture Sensor	3-19
Serial Communications	3-21
Baud Rate.....	3-22
Parity	3-22
Data Bits.....	3-23
Stop Bits.....	3-23
Flow Control.....	3-24
Power Management	3-25
Low Power (Sleep Mode).....	3-25
Shut Down	3-26

RF Network.....	3-26
About Bluetooth®	3-27
Defaults	3-28
Changing the Communication Settings	3-28
Bluetooth Settings	3-28
Enabling the Security	3-29
Changing the PIN	3-30
Local Name	3-31
Local Address	3-32
Printing Info	3-32

INTRODUCTION

Use this *System Administrator's Guide* for the Monarch® Sierra Sport2™ 9460™ printer. Review the printer information in the *Operator's Handbook* available on our Web site (www.paxar.com) before you read this manual.

Note: Information in this document supercedes information in previous versions. Check our Web site for the latest documentation and release information.

Using This Manual

Following is a summary of the contents of this manual.

	Chapter	Contents
1	Introduction	Information you should know before using the printer.
2	Using Diagnostics	Using printer diagnostics to print test labels, check sensors, view inches printed, etc.
3	Setting Up the Printer	Using the setup menu to adjust the supply and printer settings.

Audience

The *System Administrator's Guide* is for the person who sets up the printer and changes the configuration.

Using the Menu Charts

The chapters in this manual have one or more charts showing the printer's menu structure. For example:

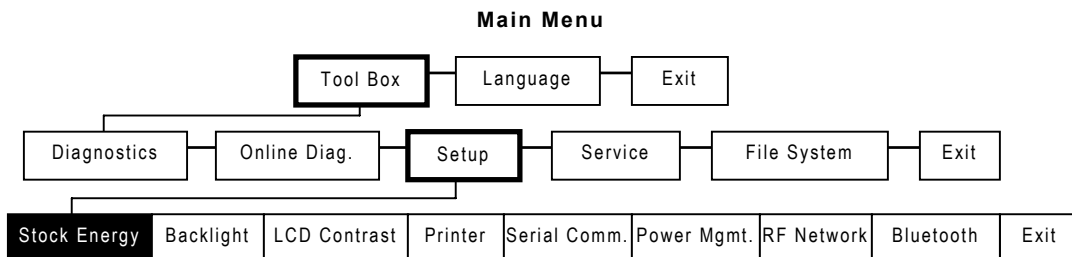



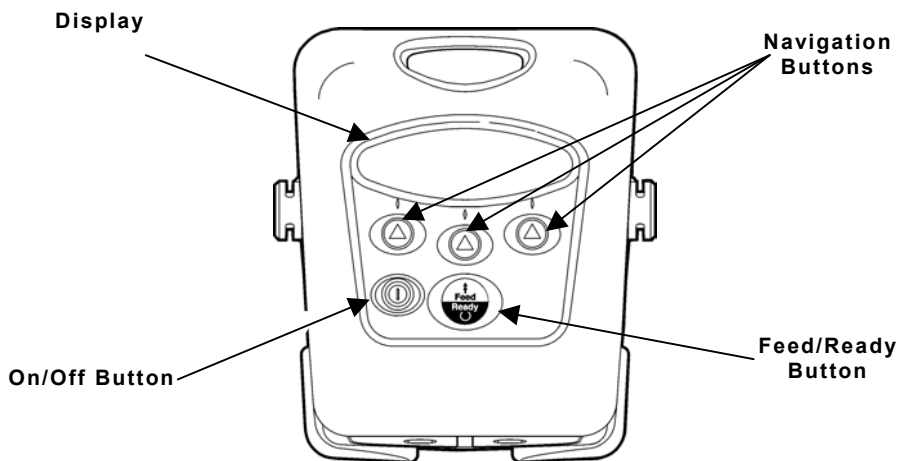

The black boxes show where you are; the bordered boxes show how you got there.

Using the Display and Buttons

- Ⓞ Turns the printer on and off.
- Ⓢ Advances the supply or returns the display to the next higher menu.
- Ⓚ Three navigation buttons for selecting options on the display.





The following table describes the icons you may see on the display:



When you see	Press the NAVIGATION  button under the icon as described
	Selects (enters) the highlighted option.
	Scrolls up through the list of options.
	Scrolls down through the list of options.
	Sets the change position.
+	Toggles between positive and negative values. Increases the selected setting in 1-step increments. Increases the selected setting in 10-step increments.
-	Decreases the selected setting in 5-step increments.
X	Clears an error. Returns the display to the next higher menu.

Selecting an Option

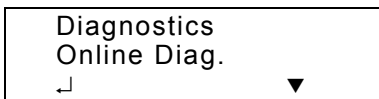

To display menu options, press any .

- ◆ When the display shows a down arrow, press  under  to scroll down through the list of options.



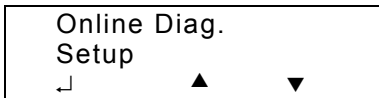



- ◆ When the displays shows an up arrow, press  under  to scroll up through the list of options.



- ◆ When the option you want is highlighted, press  under  (enter) to select it.

Exiting an Option

To exit an option, press  once. You return to the next higher menu. When you press , you lose any entries you have made since the last time you pressed  under .

Printing

The host sends online packets containing print jobs to the printer.

1. Turn on the printer. Press and hold  until the display turns on.

The display flashes printer version information, battery charging status, and then you see

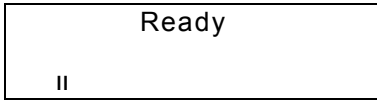

2. Download a format and a batch.

For information on creating packets and downloading print jobs, refer to the *Programmer's Manual* available on our Web site (www.paxar.com).

The printer prints either a strip of supplies (non-peel mode) or one at a time (peel/on-demand mode).

3. Remove the printed supplies.

Selecting a Language

You can change the printer's messages to English, French, German, Spanish, and Other (for future formats).

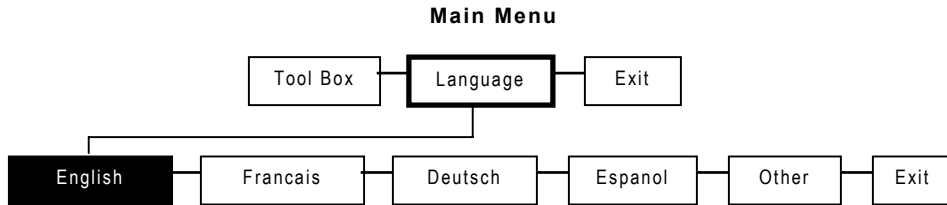

1. Turn on the printer. Press and hold until the display turns on.

The display flashes printer version information, battery charging status, and then you see

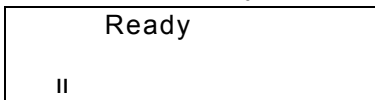

2. Press under .

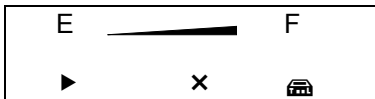

3. Press under (Tool Box) to enter the menu.

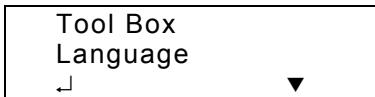

4. Press under until **Language** is highlighted.
5. Press under to select **Language**.

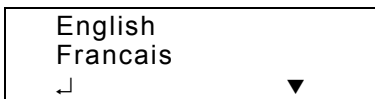

6. Press under to scroll through the options.
7. Press under to select the highlighted option.

USING DIAGNOSTICS

This chapter explains how to use the Tool Box, Diagnostics menu. Only System Administrators should perform these tests. You can view test results but you cannot change any of the settings. If there is a problem with the printer, give the results of these tests to Service.

Diagnostics

The Diagnostics menu helps diagnose problems with the printer.

Main Menu

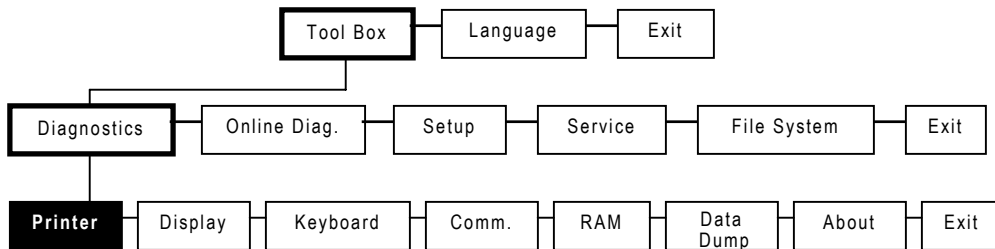

To exit, press  at any time.

1. Turn on the printer. Press and hold  until the display turns on.

The display flashes printer version information, battery charging status, and then you see

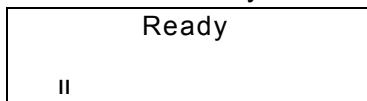



2. Press  under **ii**. You see the battery indicator E (empty) and F (full):

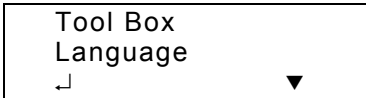

As you use the printer, the battery indicator line gets closer to E (empty), instead of F (full). Recharge the battery when the line is by the E.

3. Press  under  to enter the menu.



4. Tool Box is highlighted. Press  under  to select **Tool Box**.

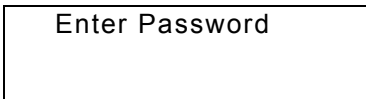

5. Press the navigational buttons in this order:
Left, Left, Left, Right, and Left.

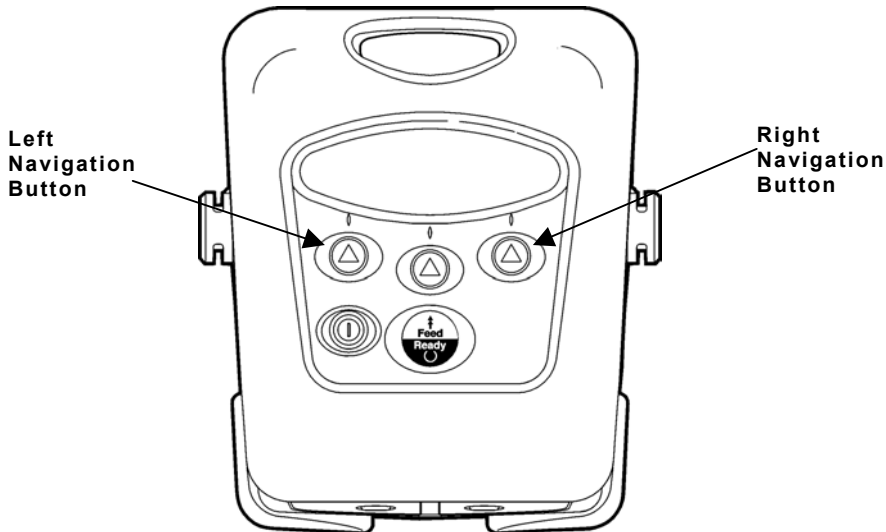

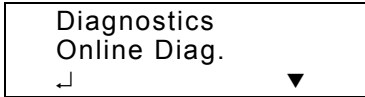

6. Diagnostics is highlighted. Press \blacktriangle under \leftarrow to select **Diagnostics**.

You are in the Diagnostics menu.

Printer

Use this menu to print a test label, check the sensors, printhead, battery, and view totals.

Diagnostics Menu

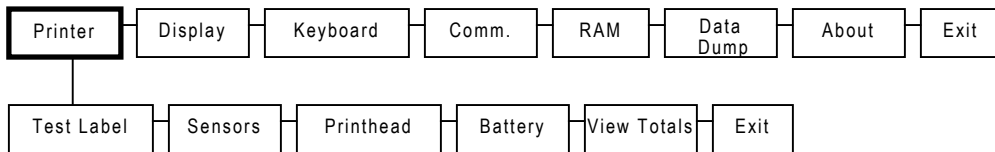

To exit, press ⏏ at any time.

Test Label

This option allows you to print three different types of test labels: diagnostic labels, the test pattern, and the grey scale test label.

1. From the Diagnostics menu, select **Printer, Test Label, Diag Label**.

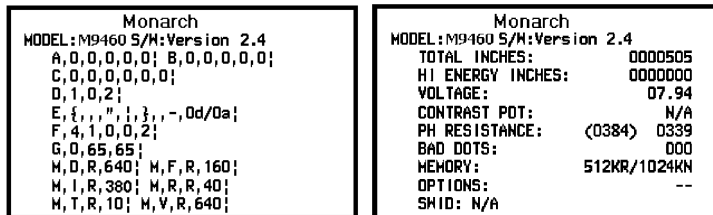

Two diagnostic labels print and you return to the Test Label menu. The test labels show the printer's configuration, the model number, and software version number.

The first label shows the printer's configuration by packet (A-M). Refer to the *Programmer's Manual* for more information. The second label shows the model number, software version, total number of inches printed, number of high-energy inches printed, voltage, contrast, printhead resistance, the number of bad dots, memory, and any options.

You return to the Test Label menu.

2. Select **Test Pattern**.

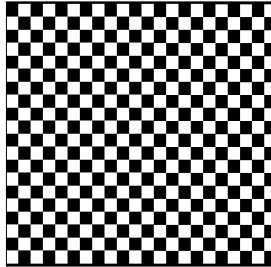

A test pattern label prints and verifies the dots on the printhead are working. You return to the Test Label menu.

If your printed sample has fewer lines or no lines, keep the sample and call Service.

Note: You may receive a "Memory Full" error if you are using MPCL because you need to reallocate memory. Refer to the *Programmer's Manual* for more information.

3. Select **Grey Scale**.

A grey scale label prints to check the uniformity of the printing. You return to the Test Label menu.

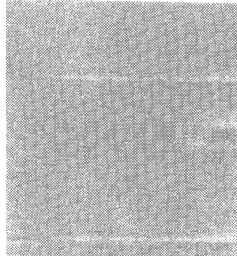

Label with voids

The test sample should be uniformly grey across the supply. If you see voids, especially on the edges, save your sample and call Service.

Note: You may receive a "Memory Full" error if you are using MPCL because you need to reallocate memory. Refer to the *Programmer's Manual* for more information.

4. Select **MIF Info**.

MIF stands for Monarch Initialization Files. MIF files specify parameters for the printer.

A test label prints displaying the settings for the printer. The line beginning with SWID indicates if a custom MIF file is loaded.

If there is no MIF file, you will see "No MIF" and you will not get a test print.

You return to the Test Label menu.

5. Press  to return to the Diagnostics menu.

Monarch	
MODEL: M9460 S/H: Version 2.4	
TOTAL INCHES:	0000505
HI ENERGY INCHES:	0000000
VOLTAGE:	07.94
CONTRAST POT:	N/A
PH RESISTANCE:	(0384) 0339
BAD DOTS:	000
MEMORY:	512KR/1024KN
OPTIONS:	--
SMID: 120140	

Sensors

Use this option to view the black mark, die cut, on-demand, and aperture sensor settings.

To exit, press  at any time.

1. From the Diagnostics menu, select **Printer, Sensors, Black Mark.**

Black Mark
A/D Value = 170

The acceptable range is between 0 and 255 and the A/D values change as supply moves past the sensors. The count changes by at least 100 steps when a black mark is under the sensor. If you do not notice at least a 100-step difference, you may need to call Service.

2. Press  to return to the Sensors menu.
3. Select **Die Cut.**

Die Cut
A/D Value = 170



The acceptable range is between 0 and 255 and the A/D values change as supply moves past the sensors. The count changes by at least 100 steps when die cut labels move through the sensor. If you do not notice at least a 100-step difference, you may need to call Service.

4. Press  to return to the Sensors menu.

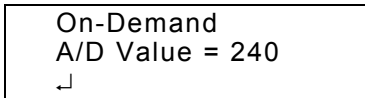
5. Select **On-Demand**.



The acceptable range is between 0 and 255 and the A/D values change as supply moves past the sensors. The count changes by 100 steps when a label is not under the sensor. If you do not notice a 100-step difference, you may need to call Service.

6. Press  to return to the Sensors menu.

7. Select **Aperture**.

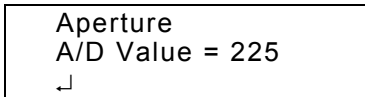

The acceptable range is between 0 and 255 and the A/D values change as supply moves past the sensors. The count changes by 100 steps when a label is not under the sensor. If you do not notice a 100-step difference, you may need to call Service.

8. Press  until you return to the Diagnostics menu.

Printhead

Use this option to check the printhead for bad dots, view the printhead dot resistance and the printhead temperature.

To exit, press  at any time.

1. From the Diagnostics menu, select **Printer, Printhead, Dot Test.**

Print Head
Bad Dots = 0



To print, the number of bad dots must be less than 10. If you have more than 10 bad dots, call Service.

2. Press  to return to the Printhead menu.
3. Select **Dot Resist.**





Resistance
in Ohms = 170

The acceptable range is between 247 Ohms and 458 Ohms. If the resistance is not in this range, call Service.

4. Press  to return to the Printhead menu.
5. From the Printhead menu, select Temperature.

Temperature
Degree C = 25

To print, the printhead temperature must be less than 60°C (140°F). The temperature is displayed in Celsius.

6. Press  under  or  to return to the Printhead menu.
7. Press  to return to the Printer menu.



Battery

Use this option to check the battery voltage.

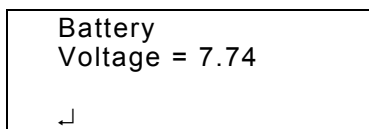
1. From the Printer menu, select **Battery**.



To print, the voltage must be greater than 7.0 volts.



2. Press  under  or  to return to the Printer menu.

View Totals

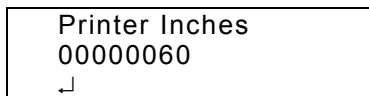

Use this option to view the totals for printer inches, service inches, printer high energy inches, and service high energy inches. The high energy printing is used for linerless labels.

1. From the Printer menu, select **View Totals, Print inch**.



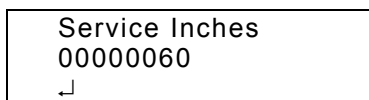

2. Press  under  or  to return to the View Totals menu.
3. Select **Service Inch**.

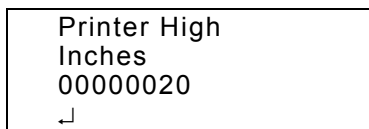

4. Press  under  or  to return to the View Totals menu.
5. Select **Prt High In**.



6. Press  under  or  to return to the View Totals menu.

7. Select **Ser High In.**

```
Service High  
Inches  
00000075  
┆
```

8. Press **▲** under **┆** or **ⓘ** to return to the View Totals menu.

9. Press **ⓘ** until you return to the Diagnostics menu.

Display

Use this menu to see if the backlight is working or if pixels are missing on the display.

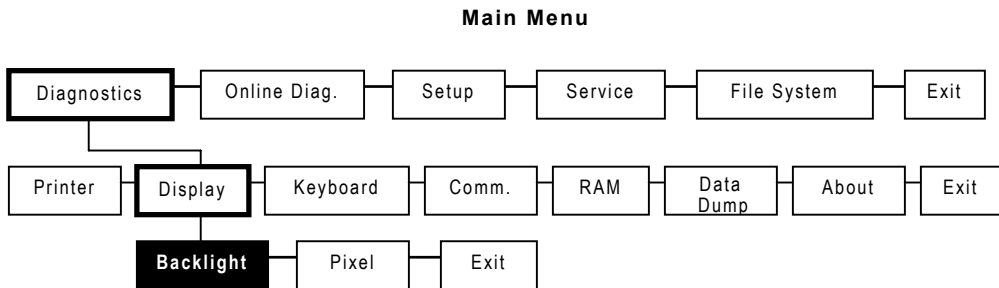

To exit, press **ⓘ** at any time.

1. From the Diagnostics menu, select **Display, Backlight.**

```
Backlight Test  
Press left key to  
toggle backlight
```

2. Press the left **▲**.

```
Backlight Test  
Press left key to  
toggle backlight  
Backlight is ON
```

The left **▲** is an ON and OFF toggle switch. Press the left **▲** again to turn ON or OFF the Backlight. You will see "Backlight is ON" or "Backlight is OFF."



3. Press **ⓘ** to return to the Display menu.

4. Select **Pixel**.

Pixel Test
Press left key to
toggle pixel
display

Each dot on the display is called a pixel.

5. Press the left . The display shows all pixels ON (black). If a pixel is not on, make a note and call Service.

The left  is an ON and OFF toggle switch. Press the left  again to turn OFF the pixels. The display shows all pixels OFF (blank screen).

6. Press until you return to the Diagnostics menu.

Keyboard

Use this menu to see if the buttons on the keyboard are working properly.

Main Menu

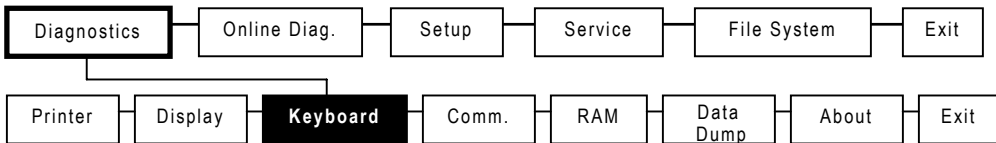

To exit, press  at any time.

1. From the Diagnostics menu, select **Keyboard**.

Press key

2. Press each key one at a time except for (power). The four boxes on the display represent a key. If the keys are working correctly, the boxes turn black.

Press feed to exit
■ ■ ■
■

If one of the boxes does not turn black, that key is not working properly. Make a note and call Service.

3. Press the button to return to the Diagnostics menu.

Communications

Use this menu to check the communications port and cable. You need a loopback plug for this test. The loopback plug can be purchased at your local electronics store. See Appendix A, "Specifications" for cable pin-out information.

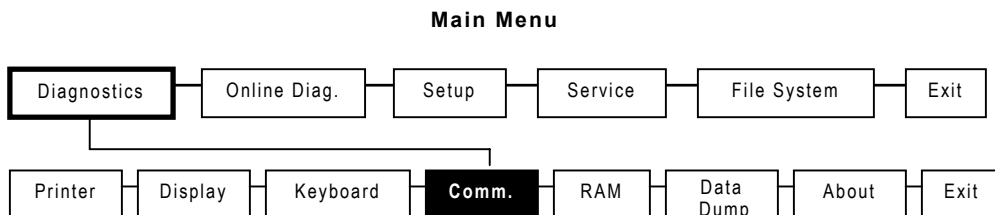

To exit, press  at any time.

1. From the Diagnostics menu, select **Comm.**

Insert loopback
Plug into serial
Port connector.
Press key to cont.

2. Press any  to continue.

The serial port test is performed.

Serial port test
Testing speed: ok
Testing parity: ok
Testing CTRLS: ok
Press key to cont.

3. Follow the instructions on the display. When you are finished, you return to the Diagnostics menu.

RAM

Use this menu to check the printer's memory.

Main Menu

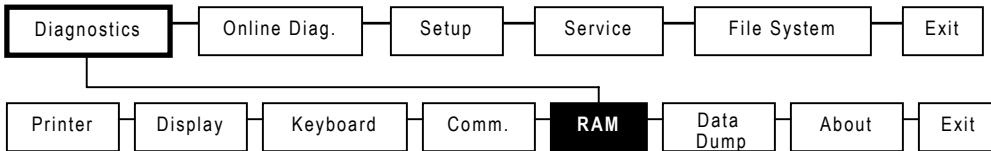

To exit, press  at any time.

1. From the Diagnostics menu, select **RAM**.

RAM test running

RAM test passed
Press a key

2. If you see a RAM error message, call Service.
3. Press any key except  (power) to return to the Diagnostics menu.

Data Dump

Use this menu if you are having problems with a data stream. Data Dump captures the data from the communications port and prints that information to a label.

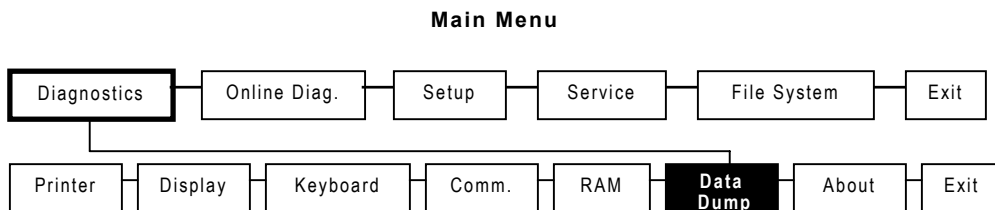

To exit, press  at any time.

1. From the Diagnostics menu, select **Data Dump**.

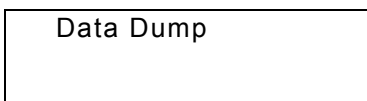

A couple of labels print with data from the communication port.

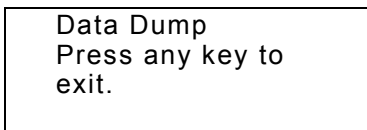

```
"08/22/04" | } 010
AD
1111 | , "G111111" | 03, "Smith" |
04, "12345678" | 05
3, "CHECKER ID: " | } 0(B,1,N,1 | 01,
"G111111 200,100,0,1,2,1,B,L,0
D 0C,330,20,0,1,1,1,B,L,0,
0,100,0,1,1,1,B,L,0,3, "DATE RE
" | 0T,5,8,V, D 0T,1,9,V,310,340
```

2. Press any key except  (power) to return to the Diagnostics menu.

About

Use this option to view information about the printer model and software version.

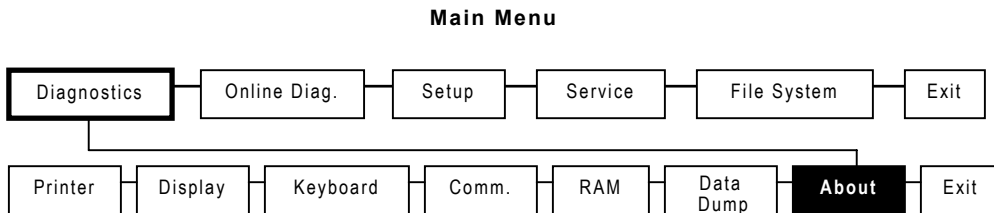

To exit, press  at any time.

1. From the Diagnostics menu, select **About**.

```
ABOUT M9460
Version 2.6
H/W Rev - P
```

The image shows a rectangular box representing the 'About' screen. Inside the box, the text is displayed as follows: 'ABOUT M9460' on the first line, 'Version 2.6' on the second line, and 'H/W Rev - P' on the third line.

2. Press  until you return to the Tool Box menu.

Online Diagnostics

Online Diagnostics is only for Service Representatives, because it requires additional PC software. It allows Service to diagnose printer problems.

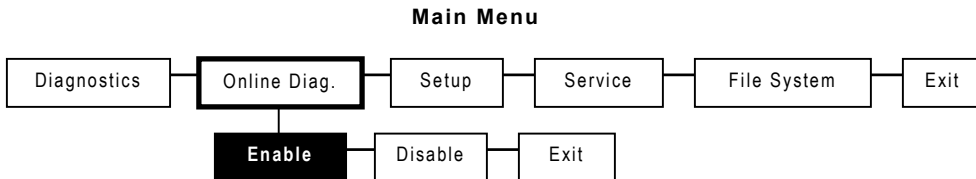

Service Diagnostics

Service Diagnostics is only accessible to a Paxar Representative, because it requires a separate password. Before calling Service, print a test label.

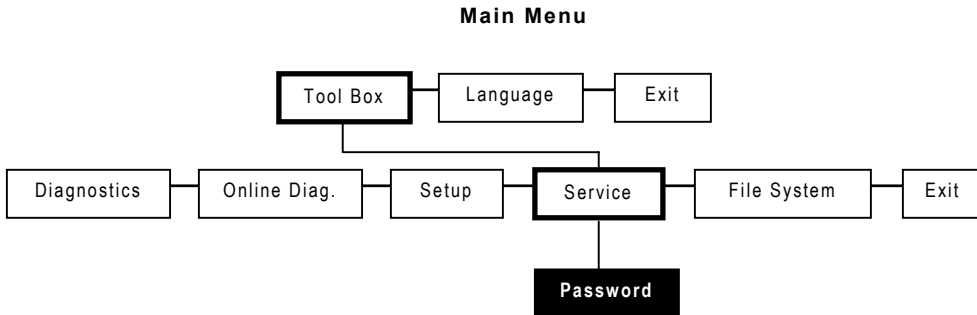

File System

The File System is only accessible to a Paxar Representative, because it requires a separate password. It clears all files that are downloaded to flash, but keeps all application files.

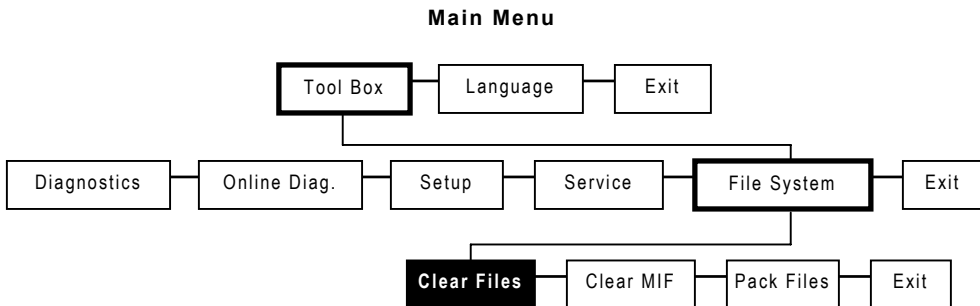

SETTING UP THE PRINTER

3

This chapter explains how to use the Tool Box, Setup menu to configure the printer.

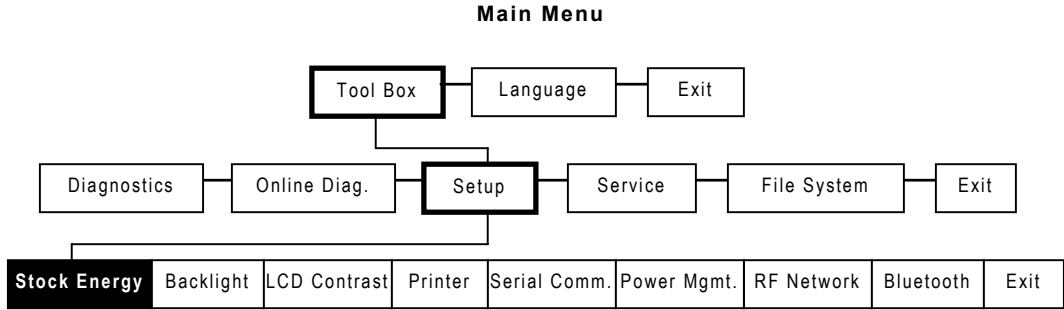

To exit, press  at any time.

1. Turn on the printer. Press and hold  until the display turns on.

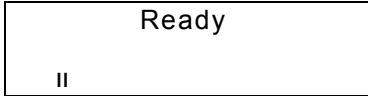

The display flashes printer version information, battery charging status, and then you see



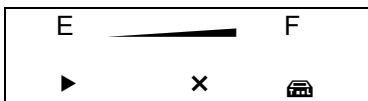

2. Press  under the || icon. You see the battery indicator E (empty) and F (full).

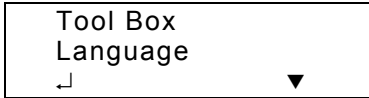

As you use the printer, the battery indicator line gets closer to E (empty), instead of F (full). Recharge the battery when the line is by the E.

3. Press  under  (Tool Box) to enter the menu.





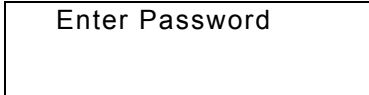

4. Tool Box is highlighted. Press  under  to select **Tool Box**.

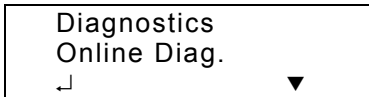

5. Press the navigational buttons in this order:

Left, Left, Left, Right, and Left.



6. Press  under  until **Setup** is highlighted.
7. Press  under  to select **Setup**.

You are in the Setup menu.

Stock Energy

Use this menu to select the type of supplies you are using. The printer supports standard or high energy supplies. Standard supplies can be either tags or labels. Use the High Energy setting for linerless and synthetic supplies. Use the Standard setting for standard supplies, including tags and receipt paper.

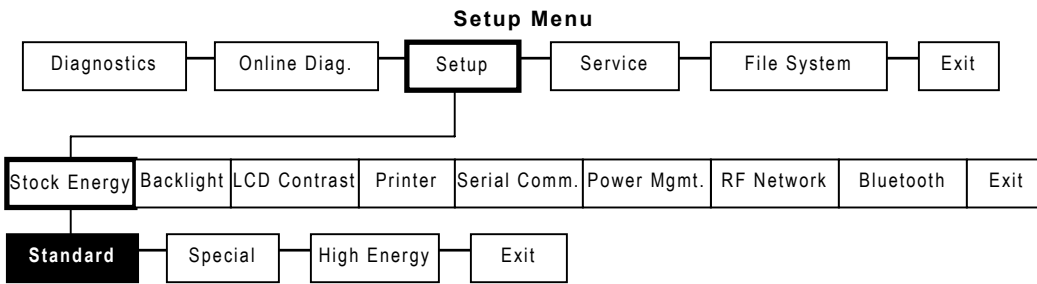

Note: The "special" setting is reserved for future supply types. **Do not** use this setting.

To exit, press  at any time.

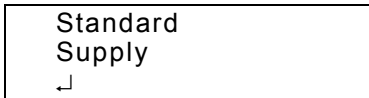

1. From the Setup menu, select **Stock Energy, Standard**.

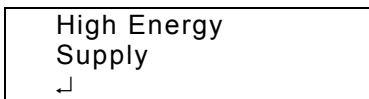

2. Press  under ↵ to save the setting. You return to the Stock Energy menu.

3. Select **High Energy**.



4. Press  under ↵ to save the setting. Use the High Energy setting for linerless and synthetic supplies. Use the Standard setting for standard supplies, including tags and receipt paper. You return to the Stock Energy menu.
5. Press  to return to the Setup menu.

Backlight

Use this menu to enable or disable the backlight. The display backlight can be enabled for dimly lit areas. The default is disabled.

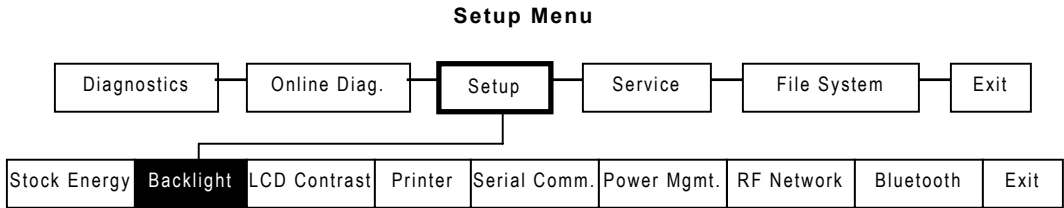

To exit, press  at any time.

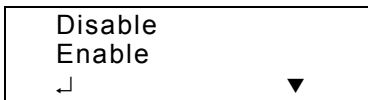

1. From the Setup menu, select **Backlight**.

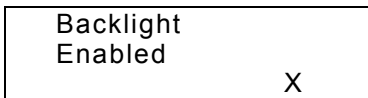

2. Make your selection: **Disable** or **Enable**. For example:



The Backlight is turned ON.

3. Press  under **X** or press  to return to the Backlight menu.
4. Press  to return to the Setup menu.

LCD Contrast

Use this menu to adjust the LCD (display) contrast depending on your viewing angle. The range is between 0 to 100. The default is 0.

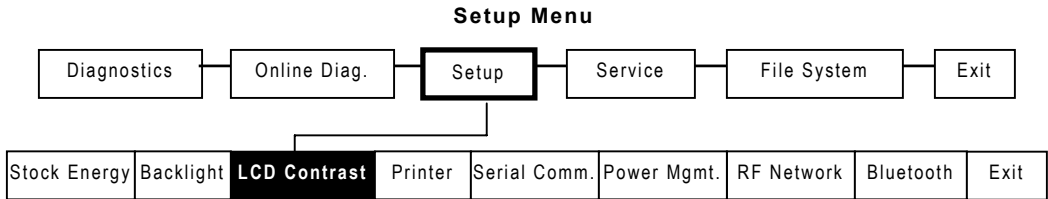

To exit, press at any time.

1. From the Setup menu, select LCD Contrast.

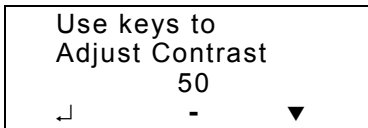

2. Press under - to decrease the contrast or press under + to increase the contrast. The contrast changes in 5-step increments (35, 40, 45, 50, etc.).
3. When the contrast you want is displayed, press under ↵ to save the setting.

You return to the Setup menu.

Printer

Use this menu to change your printer's contrast, print positions, and enable or disable the various sensors (on-demand, black mark, etc.).

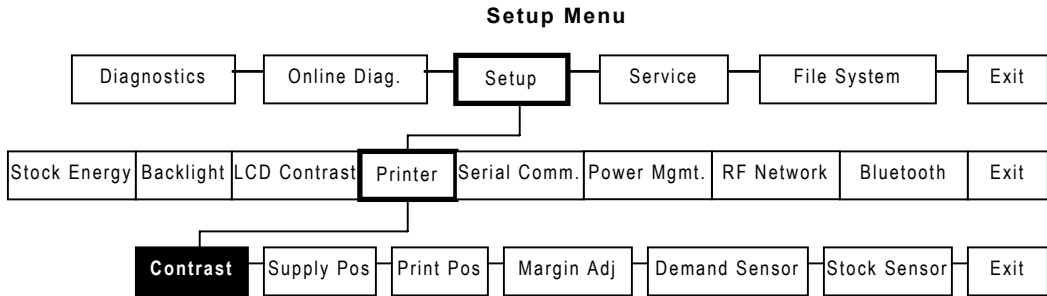

To exit, press  at any time.

Adjusting the Print Contrast

Contrast controls the darkness of the printing on your supply. The range is between -28 to 40. The default is 0.



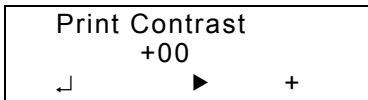

You may need to adjust your contrast based on which supply you are using. Linerless supplies may need a higher or lower contrast setting. Receipt paper requires a lower contrast setting.

For linerless or synthetic supplies, you must select High Energy from the Stock Energy menu.

1. From the Setup menu, select **Printer, Contrast**.



Use  as shown in the following table:

 Press  to	 Press  to	+ Press  to
Enter Save the setting	Set the position (+00) 1 st position 2 nd position 3 rd position	Toggle between positive and negative Increase the setting by 10 Increase the setting by 1

2. When the setting you want is displayed, press  under  to save the setting.

You return to the Printer menu.

Adjusting the Supply Position





Use this option to adjust how much supply feeds out of the printer. The range is between -99 to 99. The default is 0. You may need to adjust the supply in or out to allow

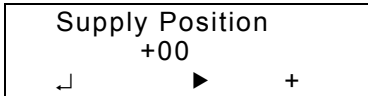

- ◆ tags and labels to be removed.
- ◆ die cut labels to be removed easily.

1. From the Printer menu, select **Supply Pos.**



Use  as shown in the following table:

 Press  to	 Press  to	+ Press  to
Enter Save the setting	Set the position (+00) 1 st position 2 nd position 3 rd position	Toggle between positive and negative Increase the setting by 10 Increase the setting by 1

2. When the setting you want is displayed, press  under  to save the setting.

You return to the Printer menu.

Adjusting the Print Position

Use this option to adjust where data prints vertically on the supply. The range is between -99 to 99. The default is 0. Adjust the print if it is too close to the top or bottom of the supply, or overtypes a pre-printed area.

1. From the Printer menu, select **Print Pos.**



Use **▲** as shown in the following table:

↓ Press ▲ to	► Press ▲ to	+ Press ▲ to
Enter Save the setting	Set the position (+00) 1 st position 2 nd position 3 rd position	Toggle between positive and negative Increase the setting by 10 Increase the setting by 1

2. When the setting you want is displayed, press **▲** under ↓ to save the setting.

You return to the Printer menu.

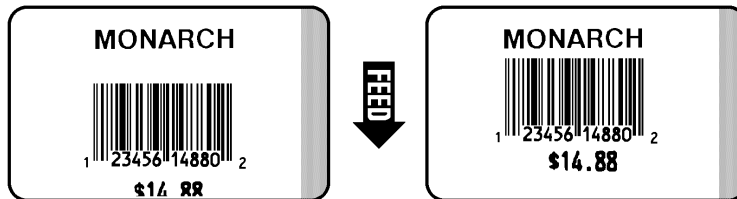

Setting the Margin Adjust

Use this option to adjust where the format prints horizontally on the supply. The range is between -99 to 99. The default is 0.

- From the Printer menu, select **Margin Adj.**

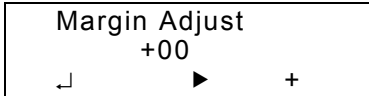

Use **▲** as shown in the following table:

↵ Press ▲ to	▶ Press ▲ to	+ Press ▲ to
Enter Save the setting	Set the position (+00) 1 st position 2 nd position 3 rd position	Toggle between positive and negative Increase the setting by 10 Increase the setting by 1

- When the setting you want is displayed, press **▲** under ↵ to save the setting. You return to the Printer menu.

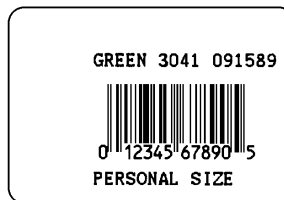

Setting the Demand Sensor

Use this option to enable or disable the on-demand sensor.

When you select:

- ◆ disable, printing is activated by pressing .
- ◆ enable, printing is automatic when the previous printing is removed.

When using on-demand with the tear edge and peel mode, you need to set up the printer:

- ◆ For tear edge, use only non-indexed supplies (continuous), supplies without separations or black marks, and linerless supplies.
- ◆ For peel mode (separates the label from the liner).

To set the on-demand sensor:

1. From the Printer menu, select **Demand Sensor**.

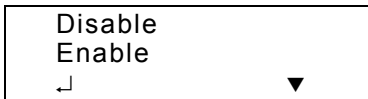

2. Make your selection: **Disable** or **Enable**. For example:

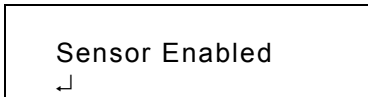

3. Press  under ↵ to save the setting.





4. Setup your printer for the tear edge or peeling labels.

For the tear edge:

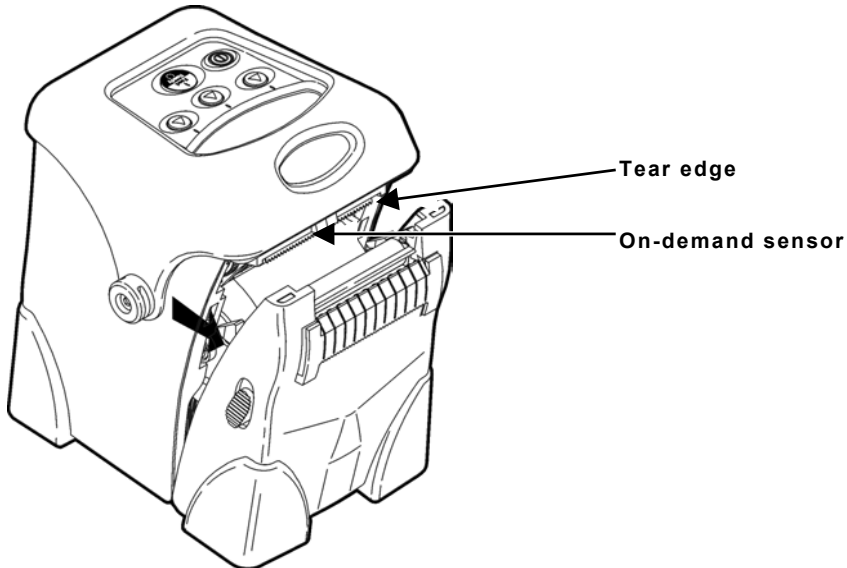
1. Remove supplies or rewind the supplies enough to make sure there is nothing under the sensor.





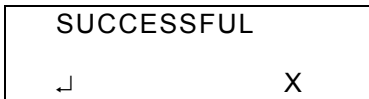

Note: The sensor needs to calibrate without supply under the sensor.

2. Close the supply door.
3. Press  under  to continue.



Note: If you see a "FAILED" message, call Service.

4. Press  under  or press  under **X** to return to the Demand Sensor menu.
5. Press  to return to the Printer menu.
6. Load supplies.

For peel mode:

1. Separate one or two labels from the liner and place the liner across the exit chute.

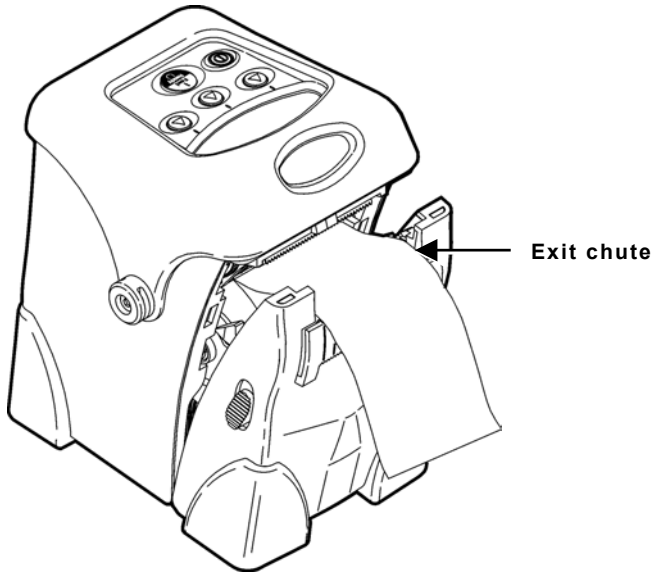

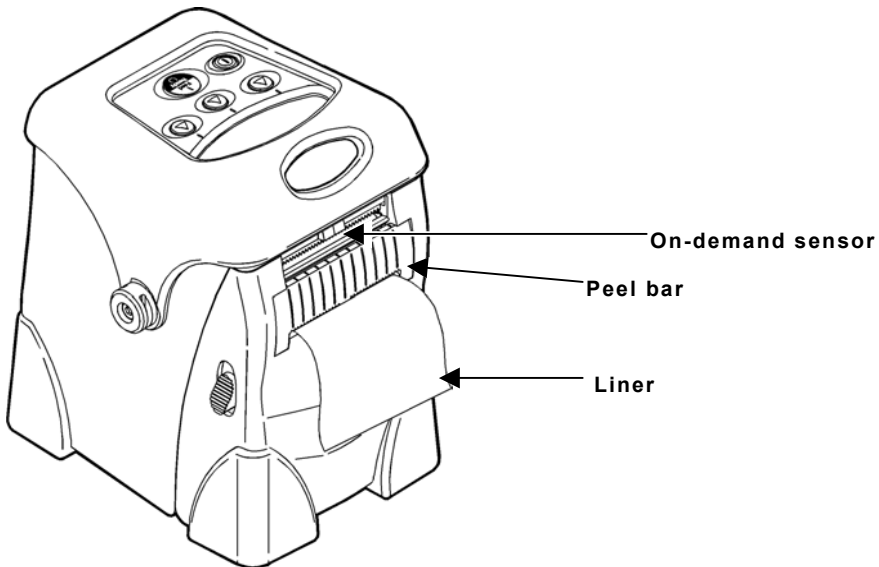

2. Feed the liner under the peel bar. The sensor needs to calibrate the liner only.





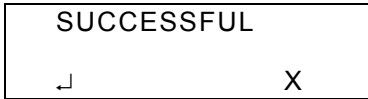

3. Close the supply door.

For more information on how to load supply for peel mode, refer to the *Operator's Handbook*.

4. Pull down on the liner to remove any slack.
5. Press  under  to continue.



Note: If you see a "FAILED" message, call Service.

6. Press  under  or press  under **X** to return to the Demand Sensor menu.
7. Press  to return to the Printer menu.

Setting the Stock Sensor

Use this option to set the sensor for die cut, black mark, non-indexed (continuous), or aperture supplies. Select the correct sensor for the supply type you are using.

Select the:

- ◆ Die-cut sensor for die cut supplies (labels on a liner with gaps between the labels).
- ◆ Black mark sensor for black mark supplies (supplies with rectangular marks on the back side of the liner or on the supply).
- ◆ Non-indexed sensor for non-indexed (continuous) supplies **without** a black mark or perforations.
- ◆ Aperture sensor for supplies with holes (apertures) in them.

Note: If you have die cut supplies with black marks, select the black mark sensor.

Selecting the Die Cut Sensor

1. From the Printer menu, select **Stock Sensor, Die Cut.**

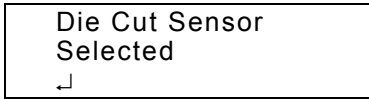



2. Press  under ↓ to continue.

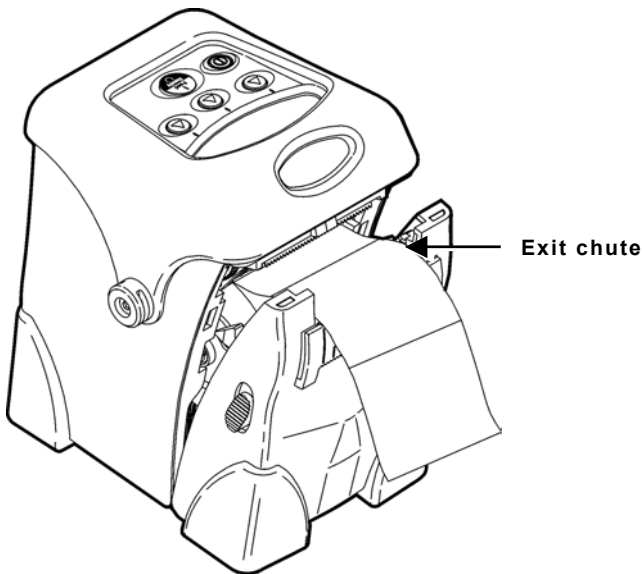

3. Load the supply by separating one or two labels from the liner and placing the liner across the black mark sensor and through the exit chute.





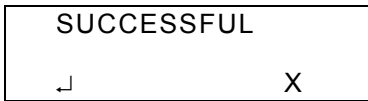

4. Close the supply door.

5. Press  under  to continue. You see a message that the printer is calibrating the supply.



The printer does not feed labels while calibrating. The printer records the sensor value read from the liner.

Note: If you get a FAILED message: turn off the printer and repeat the process. If it fails again, call Service.

6. Press  under  or press  under **X** to return to the Stock Sensor menu.
7. Press  to return to the Printer menu.

Selecting the Black Mark Sensor

1. From the Printer menu, select **Stock Sensor, Black Mark**.



2. Press  under .

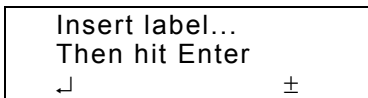

3. Load the supply by placing the supply across the exit chute *without a black mark covering the sensor*.

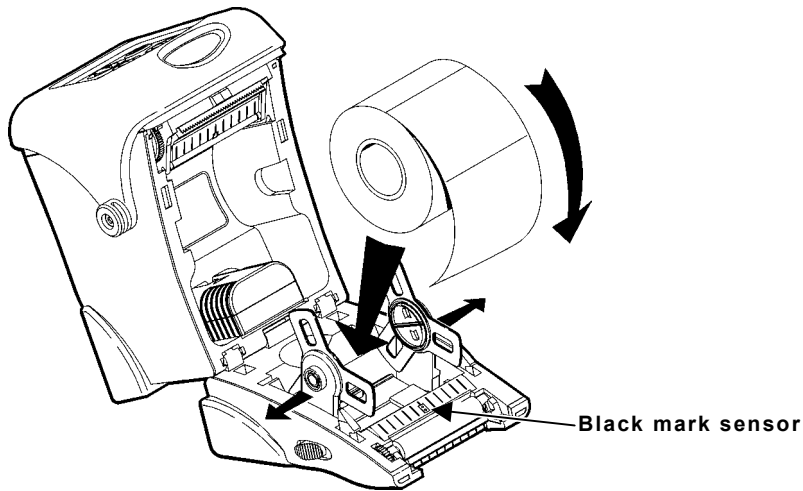

4. Close the supply door.
5. Press **▲** under **↵** to continue. You see a message that the printer is calibrating the supply.

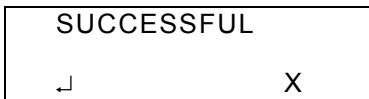

The printer does not feed supplies while calibrating. The printer records the sensor value read from the label on the liner.

6. Press **▲** under **↵** or press **▲** under **X** to return to the Stock Sensor menu.
7. Press the **⏪** button to return to the Printer menu.

Selecting the Non-Indexed Sensor

1. From the Printer menu, select **Stock Sensor, Non-Indexed**.

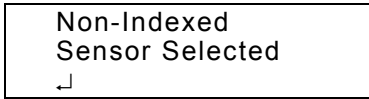



2. Press **▲** under ↵.

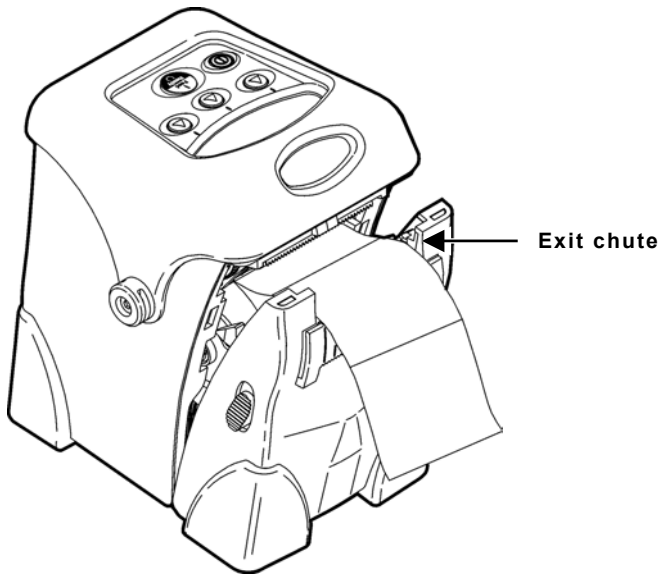

3. Load the supply by placing the supply across the exit chute.





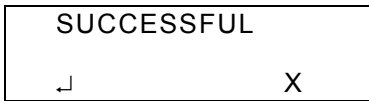

4. Close the supply door.

5. Press  under  to continue. You see a message that the printer is calibrating the supply.



The printer does not feed supplies while calibrating. The printer records the sensor value read from the label on the liner.

6. Press  under  or press  under **X** to return to the Stock Sensor menu.
7. Press  to return to the Printer menu.

Selecting the Aperture Sensor

1. From the Printer menu, select **Stock Sensor, Aperture**.

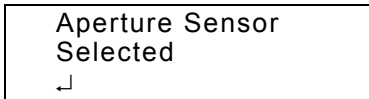

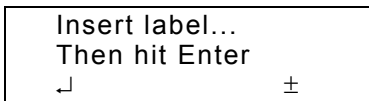

2. Press  under .



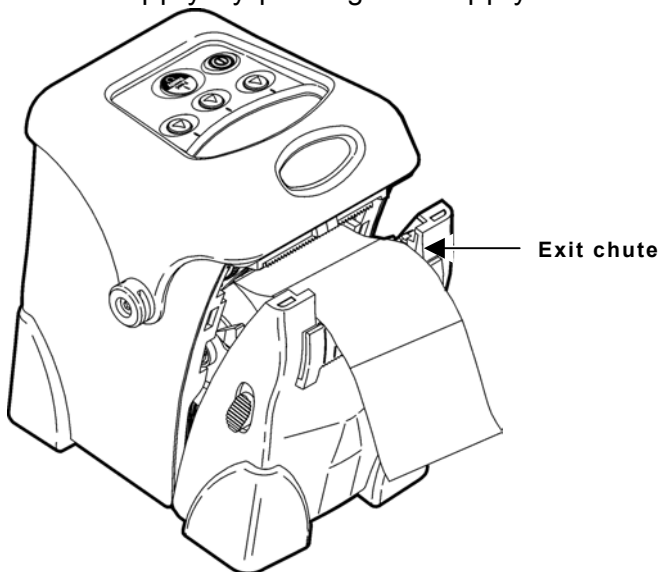



3. Load the supply by placing the supply across the exit chute.

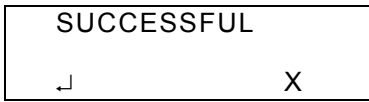

4. Close the supply door.
5. Press  under  to continue. You see a message that the printer is calibrating the supply.



The printer does not feed supplies while calibrating. The printer records the sensor value read from the label on the liner.

6. Press  under  or press  under **X** to return to the Stock Sensor menu.
7. Press  until you return to the Setup menu.

Serial Communications

Use this menu to set the serial communication values. These values provide the link for normal online printing.

Setup Menu

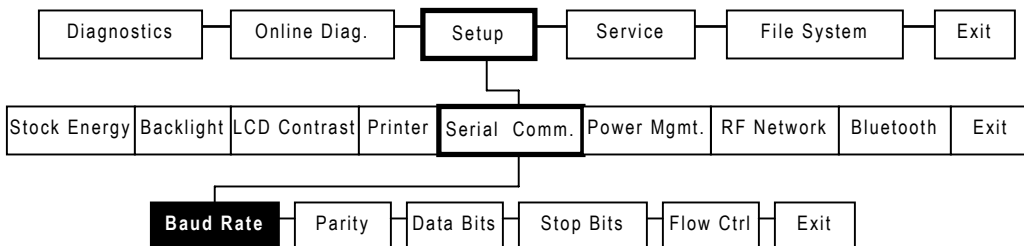

You need to set your serial communication values to match your computer's online communications.

The serial communication values are shown below.

Option	Choices	Default
Baud Rate	1200/2400/4800/9600/ 19200/38400/57600/ 115200	9600
Parity	None/Odd/Even	None
Data Bits	7/8	8
Stop Bits	1/2	1
Flow Control	No Flow/DTR Flow/ RTS Flow/Xon/Xoff/Special	DTR

Baud Rate

Use this option to set the printer's baud rate. Make sure the printer settings match those at the host.

1. From the Setup menu, select **Serial Comm, Baud Rate**.

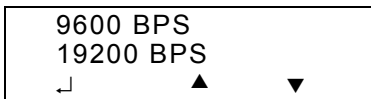



A rectangular box representing a menu. It contains two lines of text: "9600 BPS" and "19200 BPS". Below the text are three navigation symbols: a left arrow, an up arrow, and a down arrow.

BPS = bits per second.

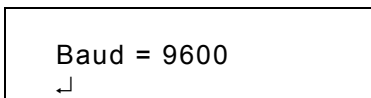
2. Make your selection: **1200, 2400, 4800, 9600, 19200, 38400, 57600,** or **115200 BPS**. For example:



A rectangular box representing a menu. It contains one line of text: "Baud = 9600". Below the text is a left arrow.

3. Press  under  to save the setting.
4. Press  to return to the Serial Comm. menu.

Parity

Use this option to set the printer's parity. Make sure the printer settings match those at the host.

1. Select **Parity**.

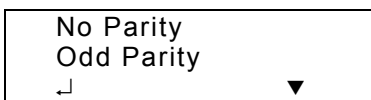

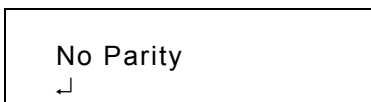

A rectangular box representing a menu. It contains two lines of text: "No Parity" and "Odd Parity". Below the text are two navigation symbols: a left arrow and a down arrow.

2. Make your selection: **No Parity, Odd Parity,** or **Even Parity**. For example:



A rectangular box representing a menu. It contains one line of text: "No Parity". Below the text is a left arrow.

3. Press  under  to save the setting.
4. Press  to return to the Serial Comm. menu.

Data Bits



Use this option to set the printer's data bits. Make sure the printer settings match those at the host.

1. Select **Data Bits**.

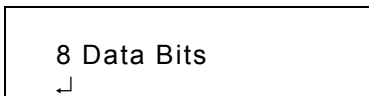

2. Make your selection: **7 Data Bits** or **8 Data Bits**. For example:



3. Press  under ↵ to save the setting.
4. Press  to return to the Serial Comm. menu.

Stop Bits

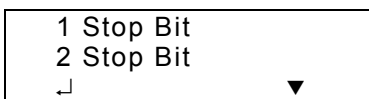

Use this option to set the printer's stop bits. Make sure the printer settings match those at the host.

1. Select **Stop Bits**.



2. Make your selection: **1 Stop Bit** or **2 Stop Bits**. For example:



3. Press  under ↵ to save the setting.
4. Press  to return to the Serial Comm. menu.

Flow Control

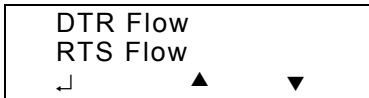

Use this option to set the printer's flow control. Make sure the printer settings match those at the host.

1. Select Flow Ctrl.



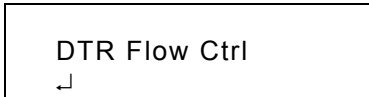



2. Make your selection: **No Flow**, **DTR Flow**, **RTS Flow**, **XON/XOFF**, or **Special**. For example:

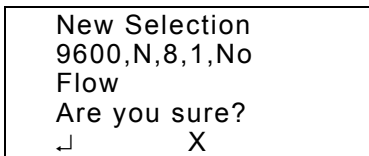

3. Press  under  to save the setting.
4. Press  until you return to the Setup menu.

If you change a setting, the new settings appear on the display.
For example:



5. Press  under  to save the setting. Or, press  under **X** to exit without saving the new setting.

Power Management

Use this menu to set the amount of time before the printer goes into sleep mode or automatically shuts down. When the printer is in sleep mode, a coffee cup icon appears on the display.

Setup Menu

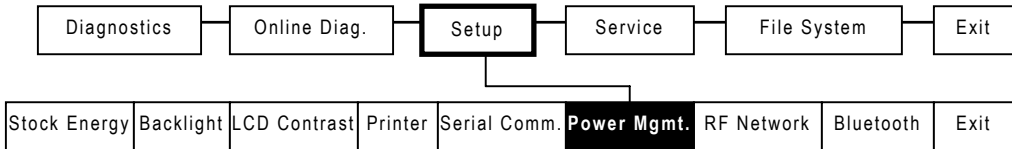

Low Power (Sleep Mode)

When the printer is inactive for a selected period of time, it goes into low power mode, or sleep mode, to conserve battery power. During sleep mode, the printer is not operational.

The default is disabled (the printer does not go into sleep mode).

However, you can set the printer to go into sleep mode from 10 seconds up to one (1) hour. The operator may press any button **except** the power button (Ⓞ) to wake up the printer.

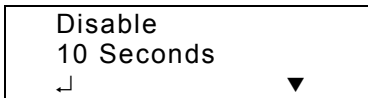

Note: Do not send print jobs to the printer during sleep mode. They will be lost.

1. From the Setup menu, select **Power Mgmt, Low-Power**.

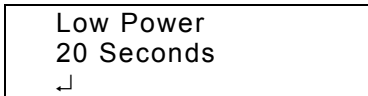

Make your selection: **Disable, 10 Seconds, 20 Seconds, 30 Seconds, 1 Minute, 2 Minutes, 5 minutes, 10 Minutes, 30 Minutes, or 1 Hour.** For example:



2. Press  under  to save the setting.
3. Press  until you return to the Setup menu.

Shut Down

You can set the printer to automatically shut down after a selected period of time. Enabling the Shut Down option will turn off the printer completely after the selected time period.

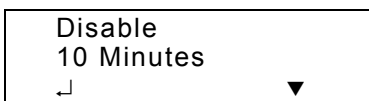

The default is disabled (the printer does not automatically shut down). However, you can set the printer to go shut down from 10 minutes up to 30 minutes

1. From the Setup menu, select **Power Mgmt, Shut Down**.

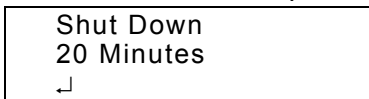

Make your selection: **Disable**, **10 Minutes**, **20 Minutes**, or **30 Minutes**. For example:



2. Press  under  to save the setting. The printer will shut down after 20 minutes.
3. Press  until you return to the Setup menu.

RF Network

If you have a network printer, refer to the *SNP System Administrator's Guide* available on our Web site (www.paxar.com) for information about configuring your RF settings using your network printer.

If your printer is not an RF printer and you try to access the RF Network menu, "Not available" appears on the display.

About Bluetooth®

Bluetooth® wireless technology is a low-power consuming way to communicate between devices. It has a maximum range of 30 feet (10m). The Bluetooth device connects to your printer's serial port and conforms to V2.0 of the Bluetooth specification.

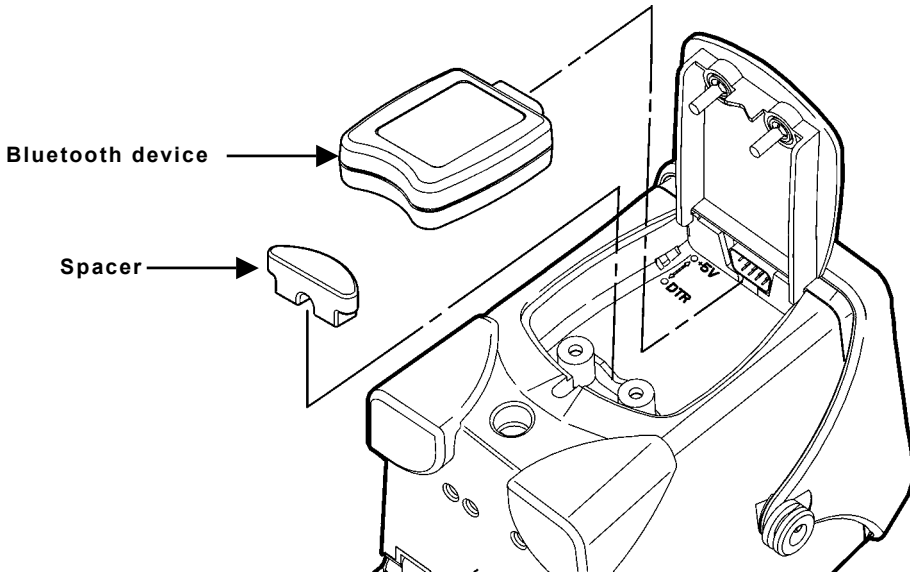

Make sure the +5V/DTR switch is set to the +5V position.

The printer defaults to receiving unencrypted data for the Bluetooth device. However, to configure the Bluetooth device to change the PIN, etc., you must use Version 2.6 or greater of the printer's firmware. Call Service if you want to upgrade your printer's firmware.

Defaults

The following defaults are set in the Bluetooth printer.

Function	Default
Security	none
PIN	0
Local Name	MONARCH PRINTER

Changing the Communication Settings

To communicate with the Bluetooth device, make sure the communication values are set to 9600, N, 8, 1, None. See "Serial Communications" earlier in this chapter for more information.

Bluetooth Settings

Use this menu to enable or disable Bluetooth security, change the PIN, modify the local name, view the local address, and print Bluetooth information labels.

Setup Menu

To exit, press  at any time.

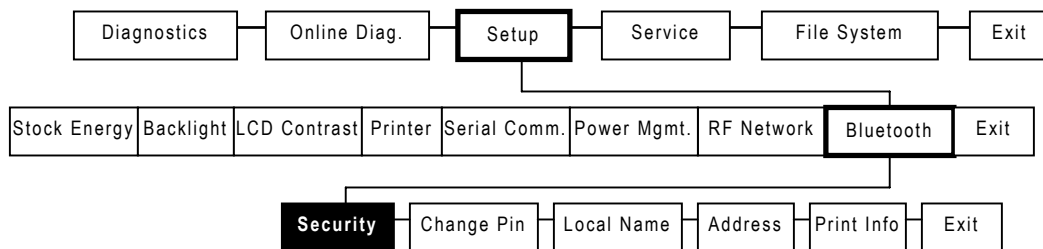

If your printer is not a Bluetooth printer and you try to access the Bluetooth menu, "Not available" appears on the display.

Enabling the Security



Use this option to enable or disable Bluetooth security.

1. From the Setup menu, select **Bluetooth, Security**.



2. Make your selection: **Enable** or **Disable**. For example:



3. Press  under  to continue.

If security is enabled, you need to set a PIN. See "Changing the PIN," for more information.

4. Press  until you return to the Bluetooth menu.

Changing the PIN

Use this option to set the Bluetooth PIN. The PIN can be up to 15 characters: 0-9. Even though a space character is displayed while you scroll through the values, the PIN cannot contain a space.





If security is enabled, you need to set a PIN. If security is disabled, you do not need to set a PIN.



1. Select **Change PIN**.

The previous PIN value appears, for example:



Use  as shown in the following table:

 Press  to	 Press  to	+ Press  to
Enter Save the setting	Scrolls through the positions from left to right	Scrolls through numbers 0-9

- When you see the setting you need, press  under  to save the setting. "PIN Changed" appears briefly on the display and you return to the Bluetooth menu.

If you need to clear digits from your PIN, make a space the second digit, save the setting, and then select **Change Pin** again. Only your first digit was saved, because the space is a terminating character.

Local Name

Use this option to view and set the Bluetooth local name. The local name can be up to 15 characters: upper-case letters A-Z, numbers 0-9, and the space character.





The local name is used for identification purposes with the host, not authentication. You should use a logical name for each printer, such as warehouse, receiving dock, etc.

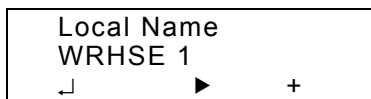

1. Select **Local Name**.

The default or last-saved local name appears, for example:



Use  as shown in the following table:

 Press  to	 Press  to	+ Press  to
Enter Save the setting	Scrolls through the positions from left to right	Scrolls through numbers 0-9

- When you see the setting you need, press  under  to save the setting. "Name Changed" appears briefly on the display and you return to the Bluetooth menu.

Local Address

Use this option to view the local Bluetooth address.

1. Select **Address**.

The local Bluetooth address is displayed, for example:

```
Local Address
00850123abc2
```

2. Press any to return to the Bluetooth menu.

Printing Info

Use this option to print a Bluetooth information label. Use 2012 or 2015 supply or information may print off the label.

1. Select **Print Info**.

"Reading" appears briefly on the display and then a Bluetooth information label prints.

The Bluetooth Information label prints the following information: if Security is Enabled or Disabled, the PIN, the Local Name, and the Address of the Bluetooth device.

```
Security Disabled
PIN:
5
Name:
WRHSE 1
Address:
0850123abc2
```

Note: The Bluetooth information label also prints as a third test label when you select **Toolbox, Diagnostics, Printer, Test Label, Diag Label**.

2. You return to the Bluetooth menu. Press to return to the Setup menu.

3. Select **Exit**. "Please wait updating" appears briefly on the display.

Visit **www.paxar.com** for sales, service,
supplies, information, and telephone numbers
for our International locations.

TOLL FREE:

1-800-543-6650 (In the U.S.A.)

1-800-363-7525 (In Canada)