

ACCESSORY INSTRUCTIONS

These instructions describe how to use the following options for carrying the Monarch® Sierra Sport2™ 9460™ and Sierra Sport4™ 9493™ portable printers:

- ◆ hip strap
- ◆ clip
- ◆ shoulder strap
- ◆ hand strap

Information in this document supercedes information in previous versions. Check our Web site (www.monarch.com) for the latest documentation and release information.

Attaching the Hip Strap and Clip

1. Put the hip strap on like a normal belt, inserting one side of the buckle into the other. The adjustment slide must face out.

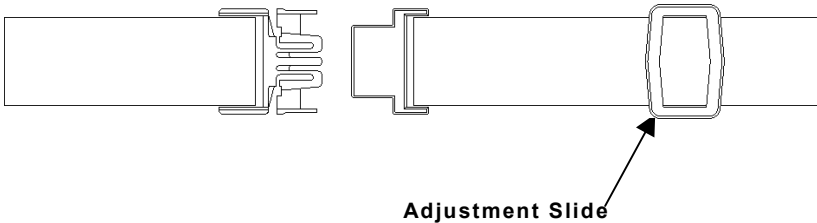

To loosen or tighten the hip strap, move the slide toward or away from the buckle.



2. Press the end of the clip and slide it all the way over the hip strap or onto a piece of clothing. The slot on the clip must face out.

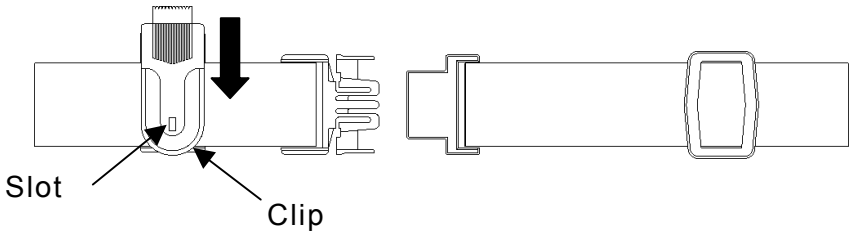

3. Lower the printer and slide the strap button into the slot on the outside of the clip until you feel it click into place.

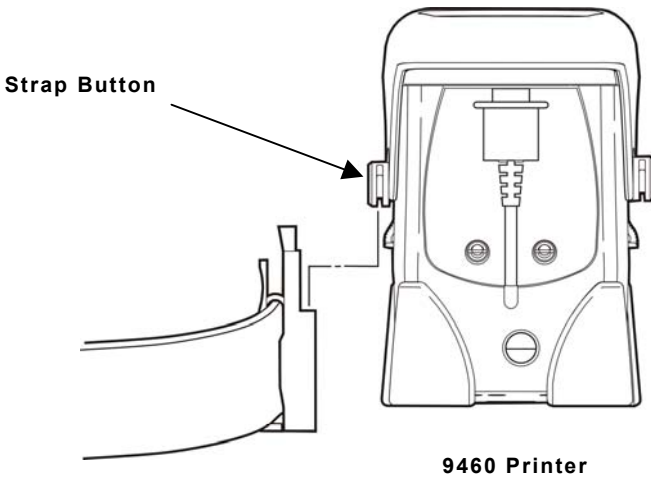

Removing the Hip Strap and Clip

1. Holding the printer with one hand, press the release switch with your other hand and lift the printer up and out of the clip.
2. To remove the hip strap, press the end of the release tabs and pull the other side of the buckle out.

Press release switch

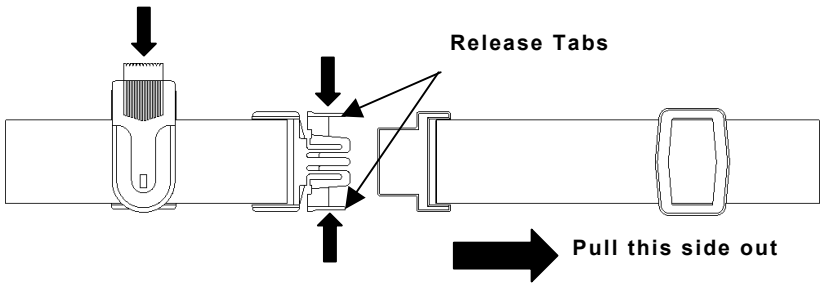

3. Press the end of the clip and pull it away from the hip strap or the piece of clothing that you attached it to.

Attaching the Shoulder and Hand Straps

1. On both sides of the printer, place the loop over the strap button, and pull up gently. You will feel it click into place.

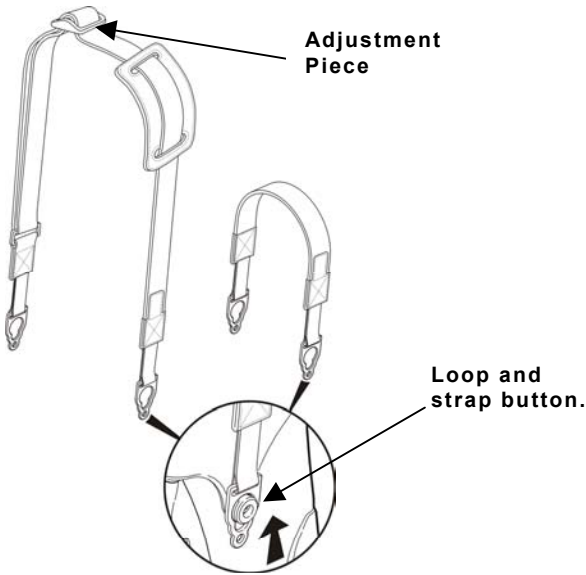

2. To raise or lower the shoulder strap, move the adjustment slide toward or away from the end of the strap.

Removing the Shoulder Strap

On both sides of the printer, gently push down on the loop attached to the button and pull it away from the printer.