

TAG TRAY INSTRUCTIONS

Use the Monarch® 927™ Tag Tray to catch tags as they exit from the knife. The tag tray does not stack tags in order. If you need a stacker, the Monarch® 928™ Stacker is available. Contact your Monarch Representative for details.

When using the tray, make sure you cut tags after each batch or after the last tag in the last batch. Refer to the optional *Packet Reference Manual* for more information about setting the cut options. Information in this document supercedes information in previous versions. Check our Web site (www.monarch.com) for the latest documentation and release information.

Note: There may be one or two tags left between the printhead and the knife, because the knife is two-and-a-half inches away from the printhead.

Installing the Tray

1. Remove two screws from the knife's cover.
2. Attach the metal plate to the front of the knife cover using the two Phillips screws provided.

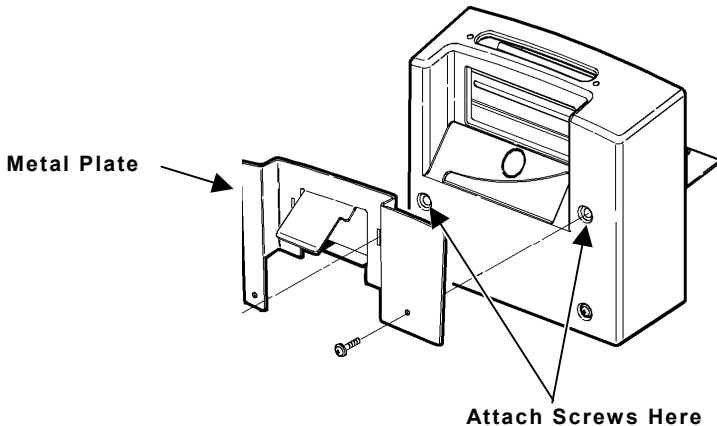

Monarch®, 927, and 928 are trademarks of Avery Dennison Retail Information Services LLC. Avery Dennison® is a trademark of Avery Dennison Corporation.



3. Insert the tray into the metal plate slots at an angle. Gently release the tray and let it drop into place.

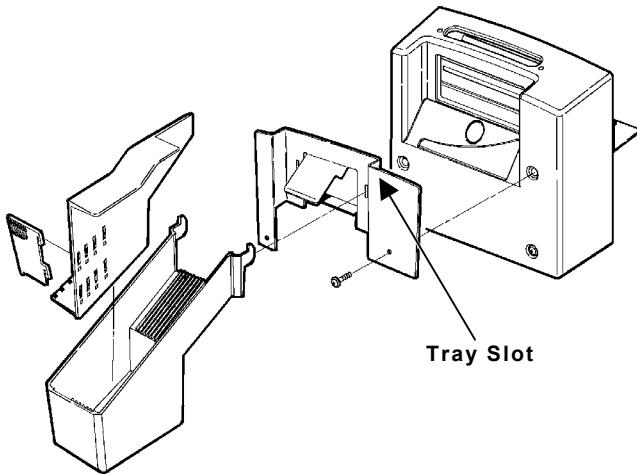

4. You need to adjust the tray for the length and width of your tags. Adjust the tray for the length of your tags first.

Adjusting the Length

Use the first length slot for 2.0-inch tags. Use the second slot for 2.5-inch tags. Use the third slot for 3.0-inch tags. Use the fourth slot for 3.5-inch tags.

Note: Do not use the length guide for 4.0-inch tags.

Insert the length guide into the slot and push down until you hear a click. Make sure the guide is inside the bottom notch. To remove the length guide, push up and remove from the slot.

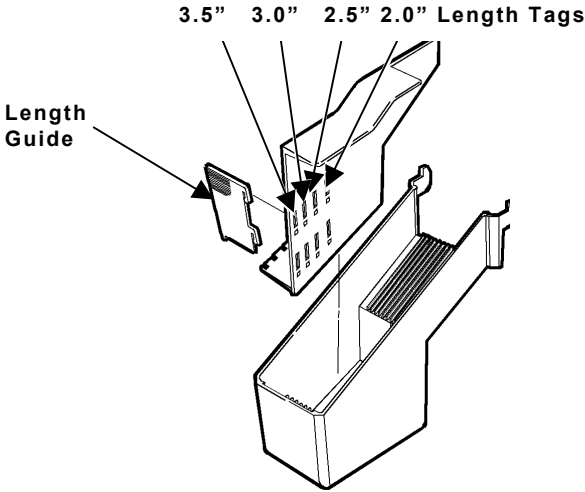

Adjusting the Width

You can only use the first three width grooves (from the right side of the tray). Place a tag in the tray and see which width works best. The tray can catch tags with a width from 1.2 inches to 2.0 inches.

Insert the width guide in the groove making sure it is straight in both (front and back) grooves.

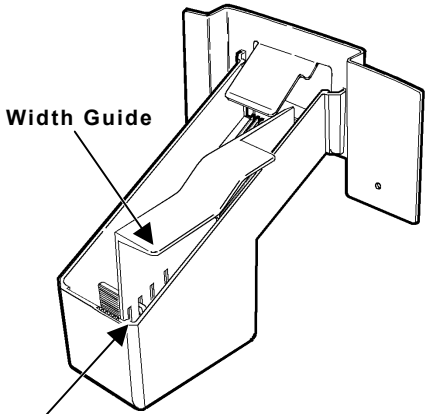

Use These Three Width Grooves

Using the Tray

- ◆ The tray simply catches tags as they exit from the knife.
- ◆ The tray is not designed to use batch separators.
- ◆ The maximum tray capacity is 75 tags.
- ◆ Remove all tags from each batch **before** sending a new batch.
- ◆ During normal operation, you may need to gently tap the tray so the tags fall to the bottom of the tray and do not jam the chute.

Note: For best results, do not leave the tray unattended.

Cleaning the Tray

Clean the tray and chute, when you see excessive paper dust by using a clean, dry cloth.

Specifications

Tag Width:	1.2 inches (30 mm) to 2.0 inches (51 mm)
Tag Length:	1.2 inches (30 mm) to 4.0 inches (102 mm)
Tag Thickness:	7 to 10 mils
Batch Quantity:	75 Maximum
Speed:	6 Inches (152 mm) Per Second maximum
Operating Range:	60° to 80° Fahrenheit
Relative Humidity:	25% to 75%