



Printer and  
Fastener Solutions

# EQUIPMENT MANUAL



## Avery Dennison® Monarch® 9419 Printer

TC9419EM Rev. AA 9/16  
© 2016 Avery Dennison Corp.  
All rights reserved.

Each product and program carries a respective written warranty, the only warranty on which the customer can rely. Avery Dennison Corp. reserves the right to make changes in the product, the programs, and their availability at any time and without notice. Although Avery Dennison Corp. has made every effort to provide complete and accurate information in this manual, Avery Dennison Corp. shall not be liable for any omissions or inaccuracies. Any update will be incorporated in a later edition of this manual.

©2016 Avery Dennison Corp. All rights reserved. No part of this publication may be reproduced, transmitted, stored in a retrieval system, or translated into any language in any form by any means, without the prior written permission of Avery Dennison Corp.

## **Trademarks**

Monarch® and MPCL are trademarks of Avery Dennison Retail Information Services LLC. Avery Dennison® is a trademark of Avery Dennison Corp.



# TABLE OF CONTENTS

<b>GETTING STARTED</b> .....	<b>1-1</b>
Audience .....	1-1
Printer Overview .....	1-2
Connecting the Power Cable .....	1-4
Establishing Communications .....	1-5
Using the Control Panel .....	1-5
Printing a Test Label .....	1-6
<b>LOADING SUPPLIES</b> .....	<b>2-1</b>
Adjusting the Platen Roller .....	2-1
Loading Rolled Supply .....	2-2
Loading Labels for Peel Mode .....	2-4
Loading Tag Supply with the Optional Cutter .....	2-7
Loading Fan-Fold Supply .....	2-9
Setting the Printer's Supply Type/Calibrating Supply .....	2-11
Setting the Feed Mode in Online Mode .....	2-12
Setting the Feed Mode in Offline (Stand-alone) Mode .....	2-12
<b>LOADING RIBBON</b> .....	<b>3-1</b>
About Ribbons .....	3-1
<b>PRINTING</b> .....	<b>4-1</b>
Online Printing .....	4-1
Offline Printing .....	4-1
Pausing While Printing .....	4-2
Canceling Printing .....	4-2
<b>CARE &amp; MAINTENANCE</b> .....	<b>5-1</b>
Clearing Label Jams .....	5-1
Cleaning .....	5-1
Replacing the Printhead .....	5-2
Replacing the Platen Roller .....	5-4
<b>TROUBLESHOOTING</b> .....	<b>6-1</b>
Adjusting the Print Quality .....	6-1
Setting the Print Contrast in Online Mode .....	6-1
Setting the Print Contrast in Offline (Stand-alone) Mode .....	6-2
Common Problems .....	6-2
<b>SPECIFICATIONS</b> .....	<b>A-1</b>
Printer .....	A-1
Supplies .....	A-2
Ribbon .....	A-2
Optional Cutter .....	A-2
Accessories .....	A-2



# GETTING STARTED

The Avery Dennison® Monarch® 9419 Printer prints on thermal transfer (ribbon) and thermal direct labels or tags. The printer prints labels continuously (in one strip) or on-demand (one label at a time). You can print on die cut, black mark, or continuous (non-indexed) supplies.

The printer operates in either online or offline mode:

Online Mode	Use online mode when the printer receives print data from a connected host (PC or network).
Offline Mode	Use offline mode (stand-alone mode) when the printer receives data from a keyboard or scanner. The printer is not connected to a host. The printer comes pre-loaded with eleven standard formats. Custom offline formats can be loaded. To use the pre-loaded formats, refer to the <i>Offline Mode System Administrator's Guide</i> .

This chapter explains how to:

- ◆ connect the power cord and communication cable.
- ◆ use the printer's control panel.

A power cord, ribbon take-up core, two ribbon reels, and a USB cable are included. Keep the box and packaging material in case the printer ever needs repair.

**Note:** Review the *Safety Document* included with your printer and the Regulatory information found on our Web site.

## Audience

---

This *Equipment Manual* is for the person who prints and applies labels.

For advanced printer setup, printer configuration, or using the Printer Management Utility, refer to the *System Administrator's Guide* for your selected operating mode (online or offline).

# Printer Overview

---

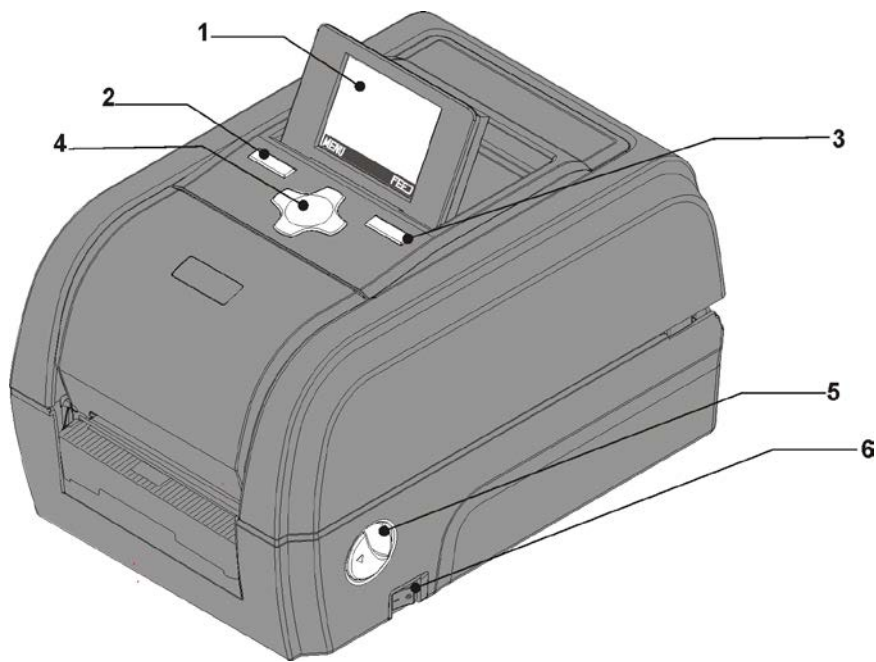

1	Display	4	Navigation Button
2	Function Button	5	Cover Latch
3	Function Button	6	Power Button

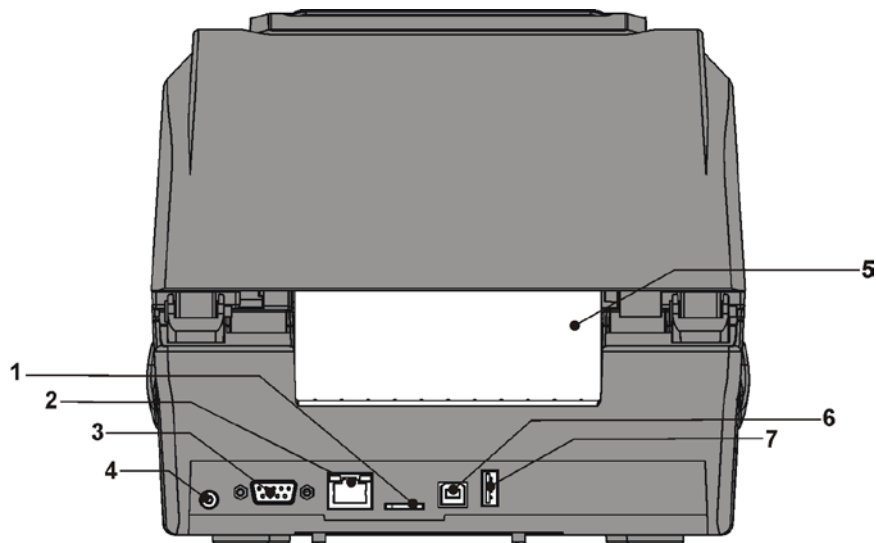

1	MicroSD Slot	5	Fan-Fold Slot
2	Ethernet	6	Device USB
3	Serial Port	7	Host USB
4	Power Socket		

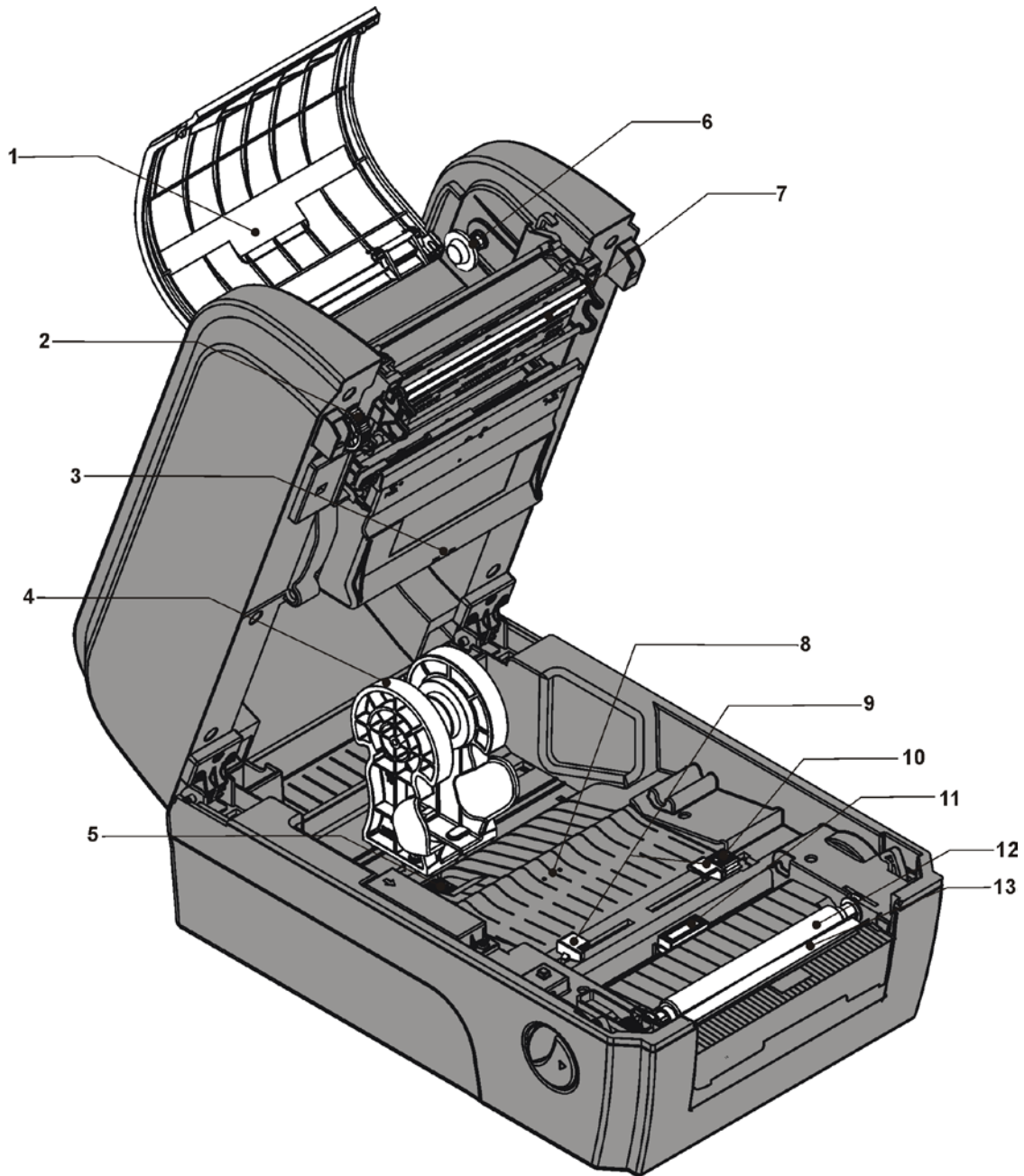

1	Ribbon Take-up Cover	8	Die Cut Sensor
2	Ribbon Take-up Gear	9	Supply Guides
3	Ribbon Cover	10	Supply Guide Button
4	Supply Holder	11	Black Mark Sensor
5	Supply Holder Lock	12	Platen Roller
6	Ribbon Take-up Reel	13	Peel Bar
7	Printhead		

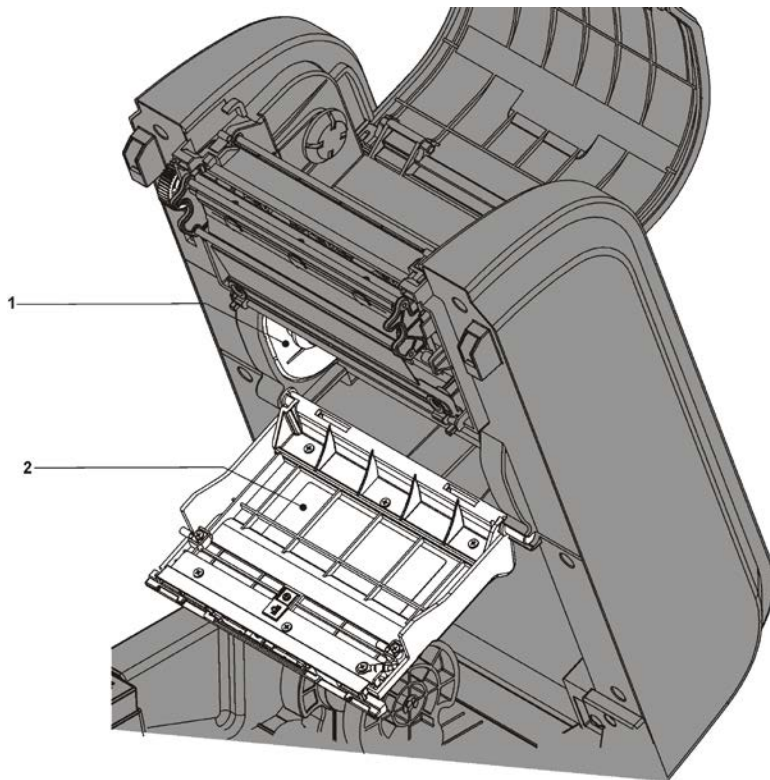

1	Ribbon Reel
2	Ribbon Cover

## Connecting the Power Cable

The power supply automatically switches between 115V or 230V. No operator settings are required.

To connect the power supply:

1. Place the printer in a location that allows easy access to the front of the printer.
2. Place the power supply in a suitable location, preferably on the floor, near an electrical outlet.
3. Plug the three-hole end of the AC adapter cable into the three-pronged outlet in the power supply.
4. Plug the round end of the power supply cable into the socket at the back of the printer.
5. Plug the three-pronged end of the AC adapter cable into a grounded electrical outlet.
6. Turn on the printer. Press the switch on the side of the printer to the ON position (I).

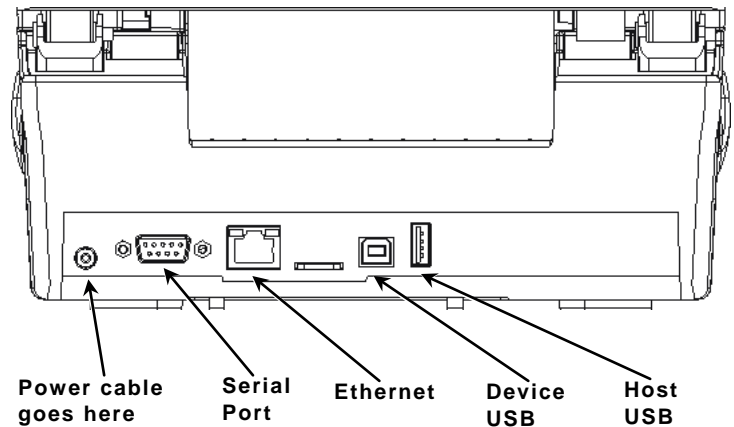

**WARNING:** The printer and power supply should never be operated in a location where either one can get wet. Personal injury could result.



# Establishing Communications

The printer can establish communications using the serial port, USB port, Ethernet port, or wirelessly (if installed). Establishing communications is required for online mode. Before the printer can accept print jobs from the host, you must:

- ◆ connect the communication cable between the printer and host or connect wirelessly.
- ◆ set the communication values on the printer to match those at the host (System Administrator only).

Ask your System Administrator which communication method to use.

## For Serial Communications:

Secure the serial cable with the connecting screws. Make sure the printer's communication values match those at the host. The printer's default values are 9600 Baud, 8 bit data frame, 1 stop bit, no parity, and DTR flow control.

## For USB Communications:

The printer has two USB 2.0 ports.

Device port      Connect to a PC and transfer data

Host port        Connect external devices, such as a keyboard, scanner, or thumb drive

## For Ethernet Communications:

The printer's display shows the IP address when a connection is established. The LEDs on the back of the printer indicate the following:

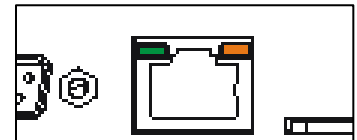

**Green LED**            Solid            A connection is present.

**Orange LED**        Blinking        Network activity/receiving data.

# Using the Control Panel

The control panel has an LCD display with two function buttons and a navigation button.

Function Button

Navigation Button

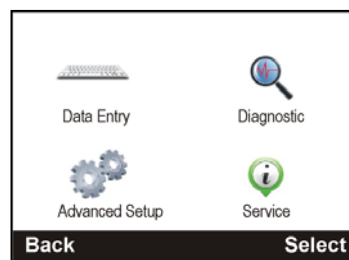
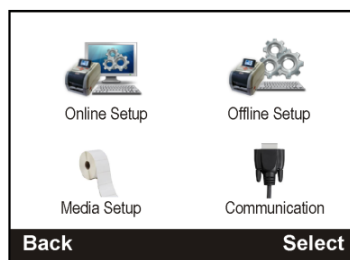
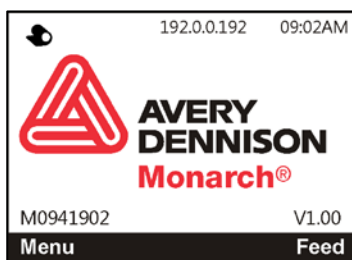
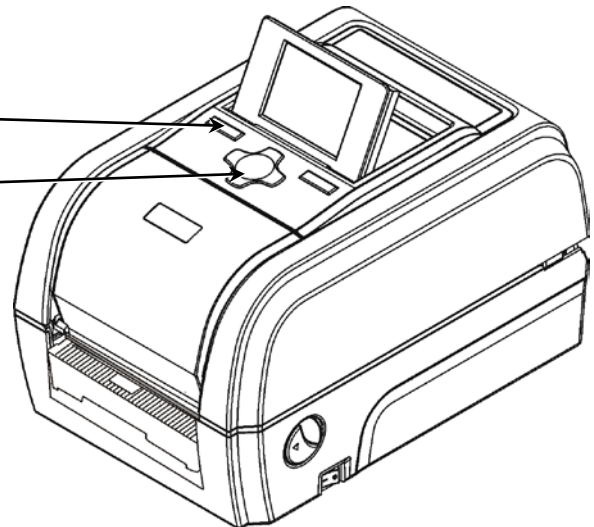

Menu Item	Description
Online Setup	Configuring the printer for use while connected to a host. Refer to the <i>Online Mode System Administrator's Guide</i> .
Offline Setup	Configuring the printer for use in offline mode (stand-alone mode) when the printer receives data from a keyboard or scanner. The printer is not connected to a host. Refer to the <i>Offline Mode System Administrator's Guide</i> .
Media Setup	Configuring the supply type and calibrating the sensors. Refer to the <i>System Administrator's Guide</i> for your selected operating mode.
Communication	Setting up serial or Ethernet communications. Refer to the <i>System Administrator's Guide</i> for your selected operating mode.
Data Entry	Select and enter data for pre-loaded formats. Refer to the <i>Offline Mode System Administrator's Guide</i> .
Diagnostic	Printing a test label or the printer's configuration, viewing printer information, etc. Refer to the <i>System Administrator's Guide</i> for your selected operating mode.
Advanced Setup	System settings such as date and time, display brightness, etc. Refer to the <i>System Administrator's Guide</i> for your selected operating mode.
Service	Contains Service information, which requires a separate password to access.

## Printing a Test Label

1. From the Main Menu, select **Menu**.
2. Press the navigation button until Diagnostics is highlighted. Press **Select**.
3. Press **Select** when Test Label is highlighted.

Contains the printer's speed, contrast, inch counts.

Contains the printer's MPCL packet configuration.

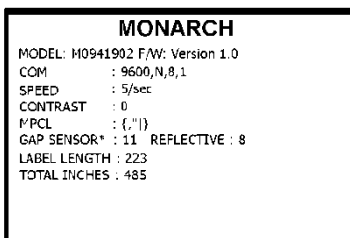

Contains network configuration.

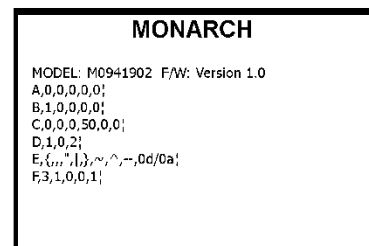

Refer to the *Packet Reference Manual*.

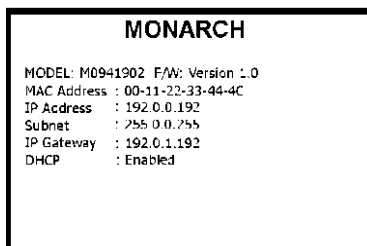

# LOADING SUPPLIES

This chapter describes how to load:

- ◆ a roll of labels or tags
- ◆ peel mode supplies
- ◆ fan-fold supply.

Ask your System Administrator which type of supply to use:

**Thermal Direct** heat activated supplies that do not use a ribbon for printing.

**Thermal Transfer** standard supplies that require a ribbon for printing.

**Note:** When using thermal direct supplies, do not load a ribbon.

When using pre-printed supply or tinted supply, your System Administrator should manually calibrate the sensor.

## Adjusting the Platen Roller

Adjust the platen roller based on supply thickness. The default setting is for label supply.

Locate the platen roller tabs. Tabs are located on either side of the platen roller. *Adjust both tabs to the same position!*

1. Turn the cover latches and lift the cover.
2. Press down and completely open the peel door.
3. Pull on the platen roller tabs and rotate up to unlock. Adjust as shown:

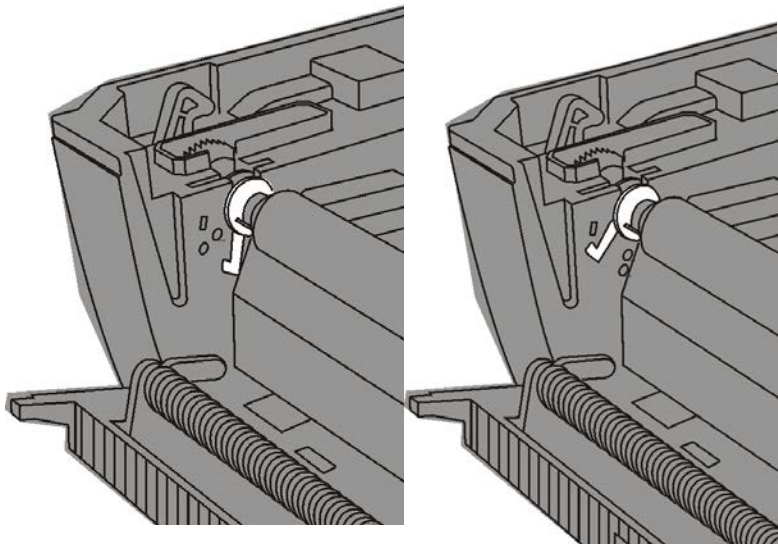

For label supplies less than 0.007 inches (0.19mm) thick, use this setting.

For supplies 0.007 inches (0.19mm) thick or greater, use this setting.

4. Close the peel door.
5. Close the cover until you hear it click into place.

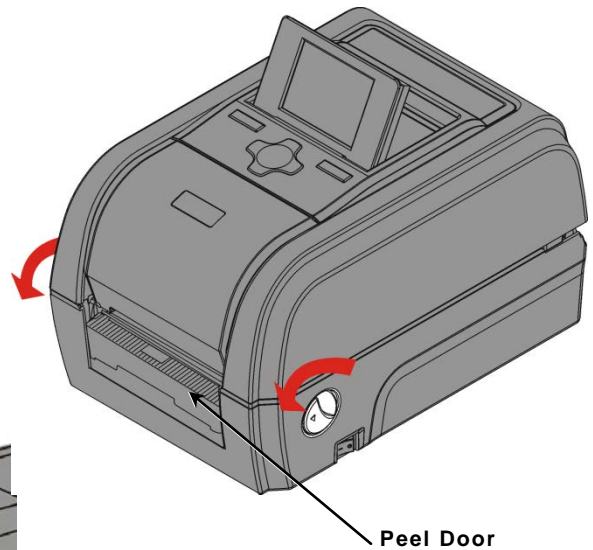

## Loading Rolled Supply

---

Adjust the platen roller based on supply thickness if necessary. See "[Adjusting the Platen Roller](#)" for more information.

1. Turn the cover latches and lift the cover.

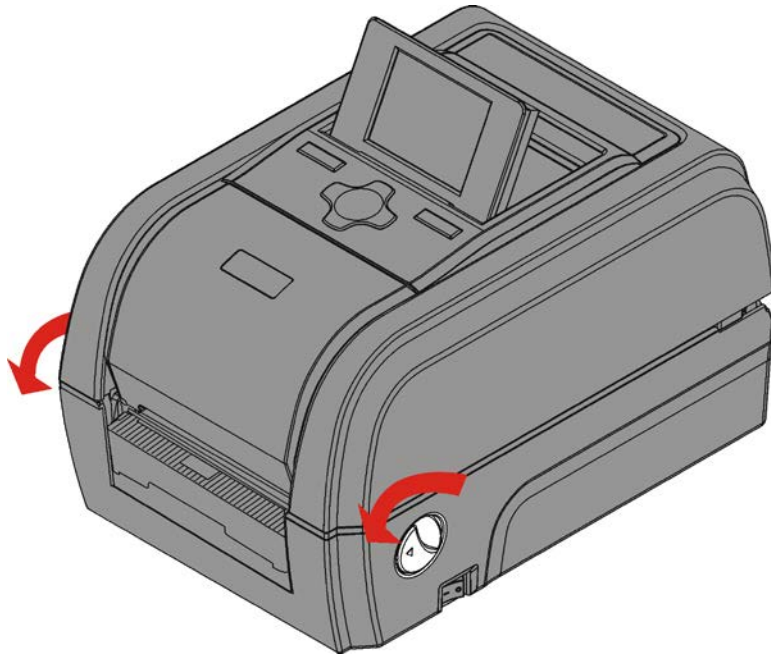

2. Use your thumb to separate the supply holders.
3. Place rolled supply (printing side up) into the supply holder. Release the supply holder. The supply holders should fit snugly against the supply.

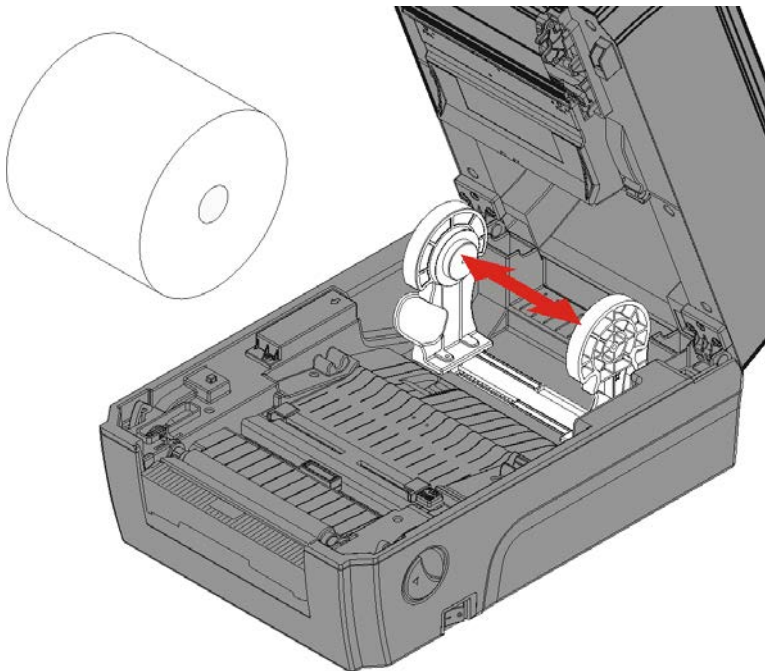

4. Feed the supply into the supply path.

5. Push the supply guide button to move the supply guides until they barely touch the supply.

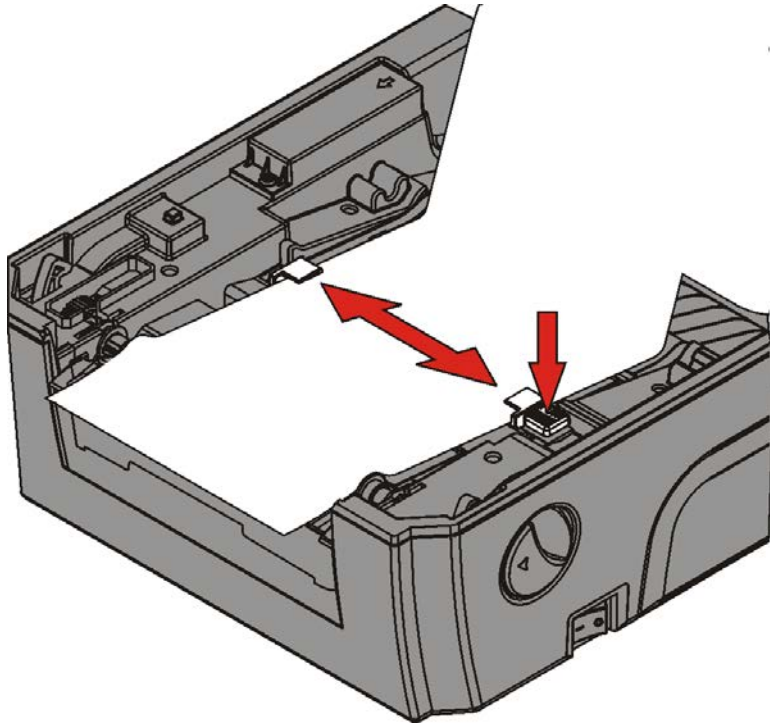

6. Lay the supply over the platen roller.
7. Close the cover until you hear it click into place.
8. Press **Feed** to position the supply under the printhead.

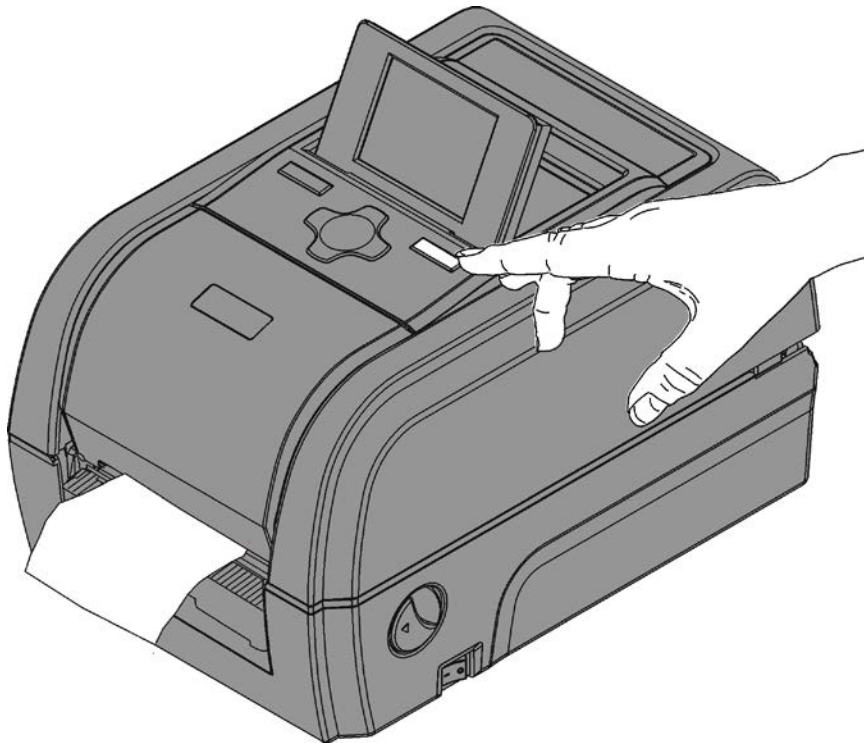

**Note:** If this is the initial printer setup or if you change the supply type (from die cut to black mark, for example), see [“Setting the Printer’s Supply Type/Calibrating Supply.”](#)

## Loading Labels for Peel Mode

---

In peel mode, the printer separates the liner from the label.

- ◆ minimum feed length is 1.0 inches.
- ◆ maximum speed is 3.0 inches (76 mm) per second.
- ◆ use non-perforated supplies.

**Note:** You may want to set the printer for on-demand mode. Hold the leading edge of peeled labels when printing on stock longer than six inches.

Adjust the platen roller based on supply thickness if necessary. See "[Adjusting the Platen Roller](#)" for more information.

1. Turn the cover latches and lift the cover.

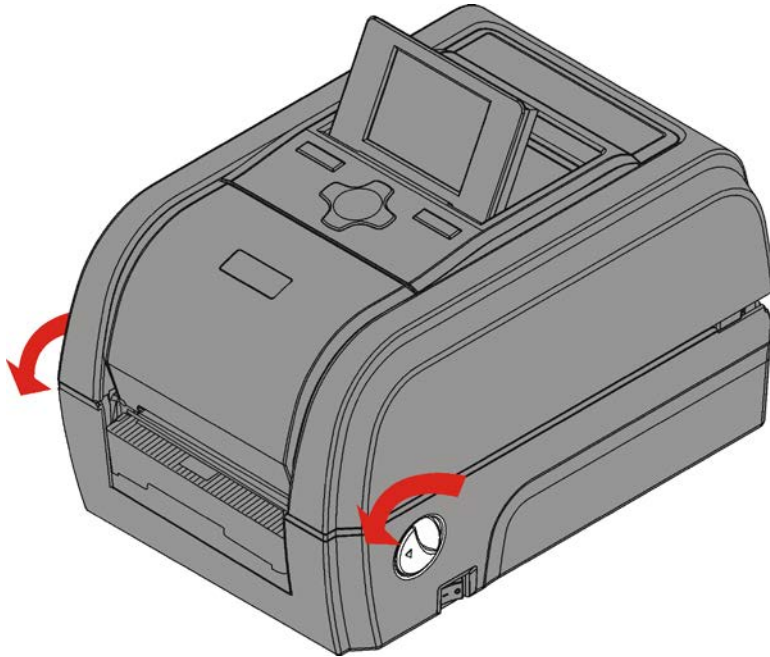

2. Use your thumb to separate the supply holders.
3. Place rolled supply (printing side up) into the supply holder. Release the supply holder. The supply holders should fit snugly against the supply.

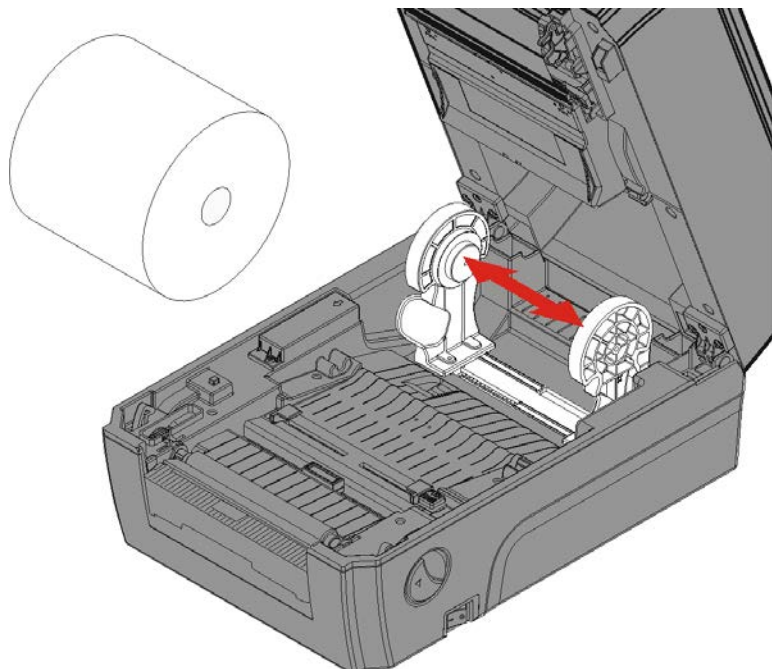

4. Feed the supply into the supply path.
5. Push the supply guide button to move the supply guides until they barely touch the supply.

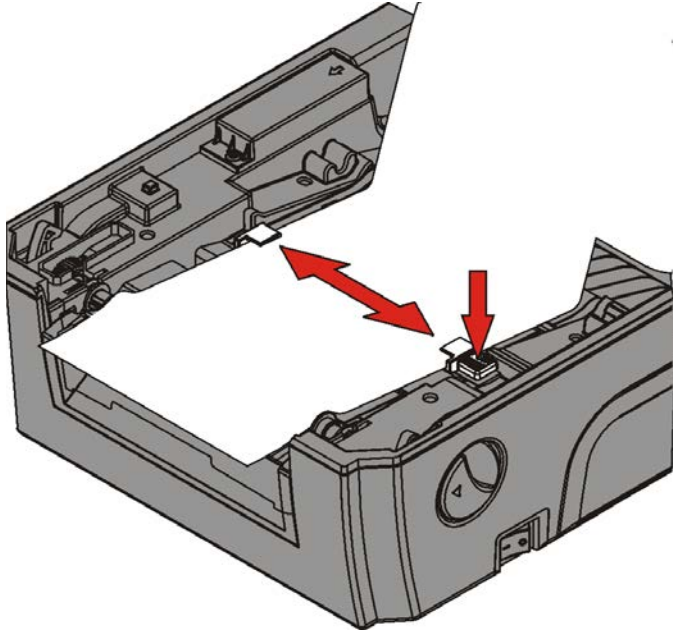

6. Lay the supply over the platen roller.
7. Remove the labels from the first 8 inches of the liner.
8. Press down and completely open the peel door.
9. Feed the liner through the opening in the peel door.

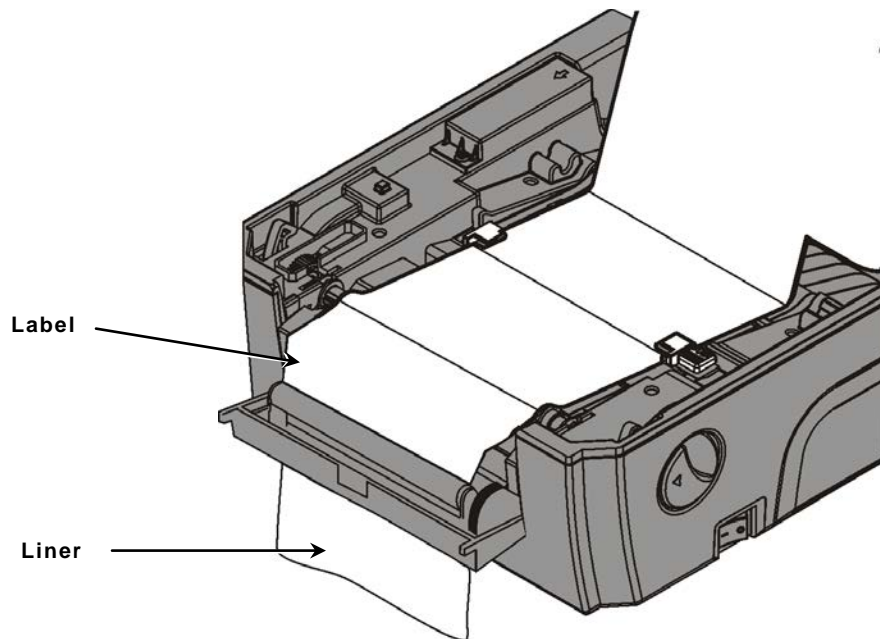

10. Close the peel door.
11. Close the cover until you hear it click into place.

12. Press **Feed** to position the supply under the printhead.

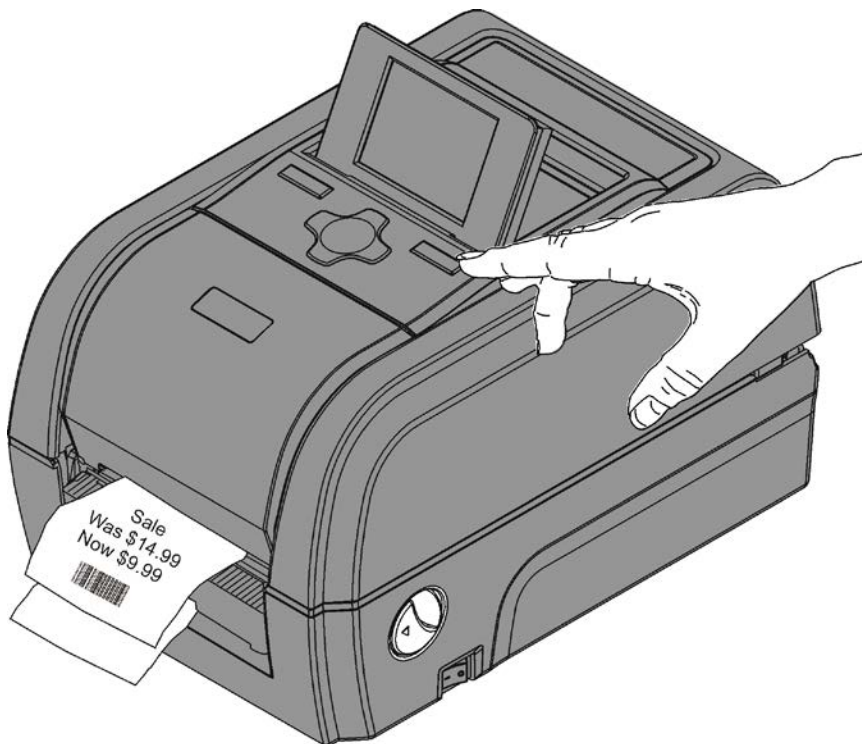

**Note:** If this is the initial printer setup or if you change the supply type (from die cut to black mark, for example), see [“Setting the Printer’s Supply Type/Calibrating Supply.”](#)



## Loading Tag Supply with the Optional Cutter

---

Follow these steps to load supply through the optional cutter. If using online mode, the cutter is enabled with the job. Refer to the *Packet Reference Manual* for more information. If using offline mode, refer to the *Offline Mode System Administrator's Guide* to enable the cutter.

Adjust the platen roller based on supply thickness if necessary. See "[Adjusting the Platen Roller](#)" for more information.

**Caution:** Do not place your fingers or any other objects into the cutter.

1. Turn the cover latches and lift the cover.

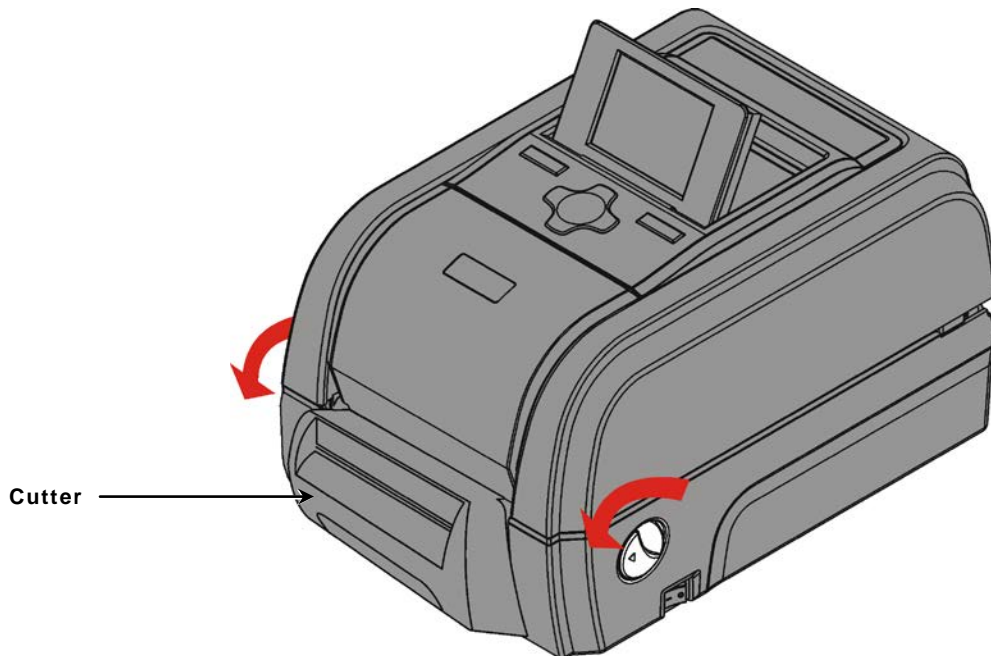

2. Use your thumb to separate the supply holders.
3. Place rolled supply (printing side up) into the supply holder. Release the supply holder. The supply holders should fit snugly against the supply.

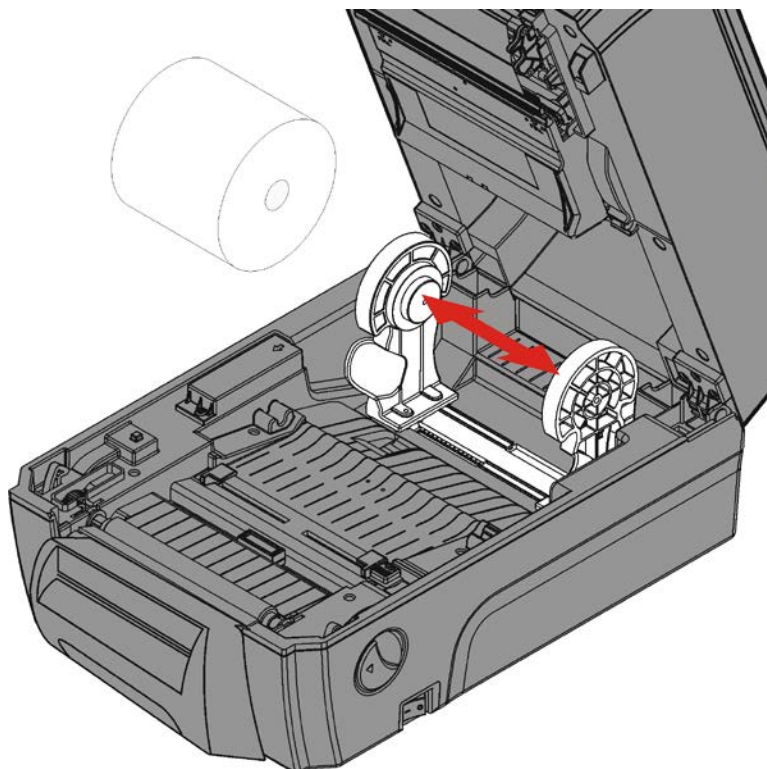

4. Feed the supply into the supply path.
5. Push the supply guide button to move the supply guides until they barely touch the supply.
6. Feed the supply over the platen roller and through the cutter's opening.

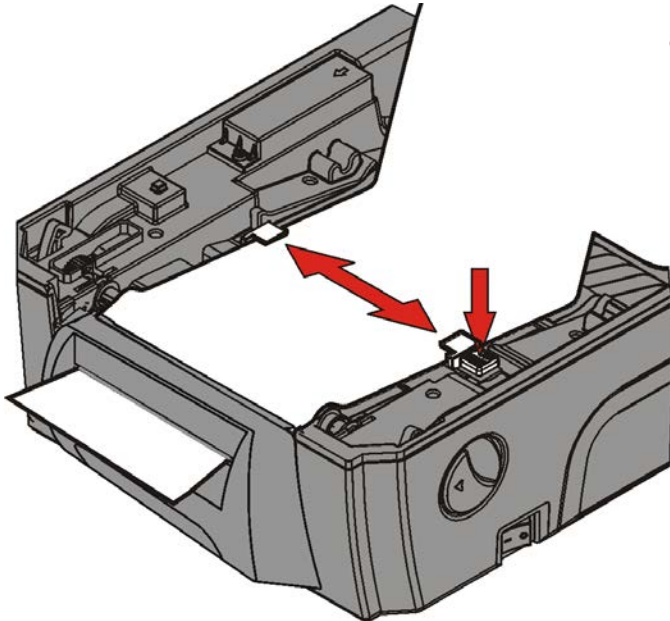

7. Close the cover until you hear it click into place.
8. Press **Feed** to position the supply under the printhead.

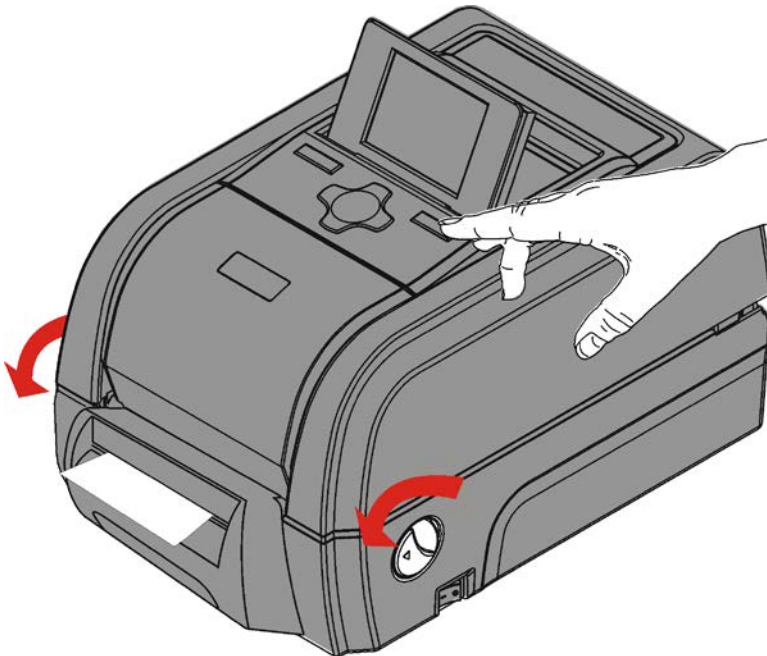

**Note:** If this is the initial printer setup or if you change the supply type (from die cut to black mark, for example), see [“Setting the Printer’s Supply Type/Calibrating Supply.”](#)

## Loading Fan-Fold Supply

---

Place the fan-fold supply stack behind the printer, label side up.

Adjust the platen roller based on supply thickness if necessary. See “[Adjusting the Platen Roller](#)” for more information.

1. Turn the cover latches and lift the cover.

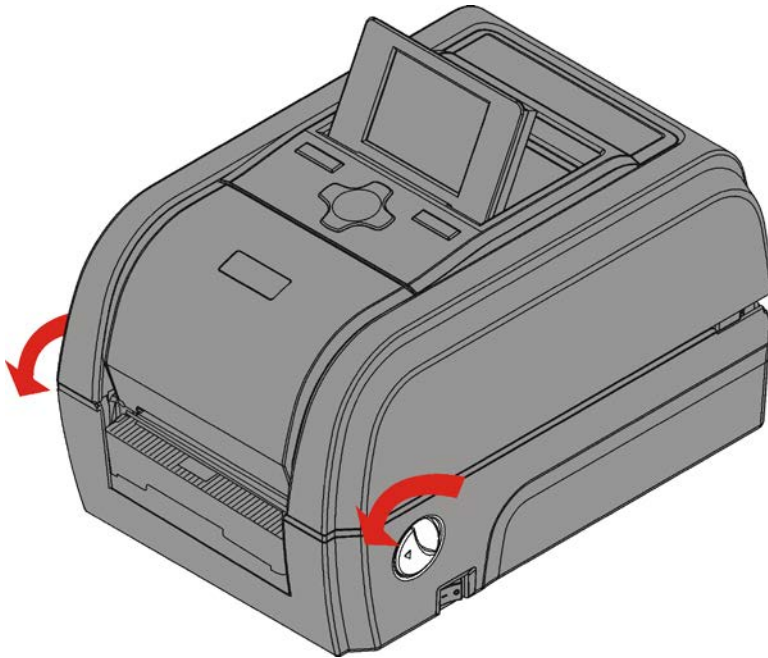

2. Use your thumb to separate the supply holders. If the supply holders do not move, pull the supply holder lock toward you to release them.

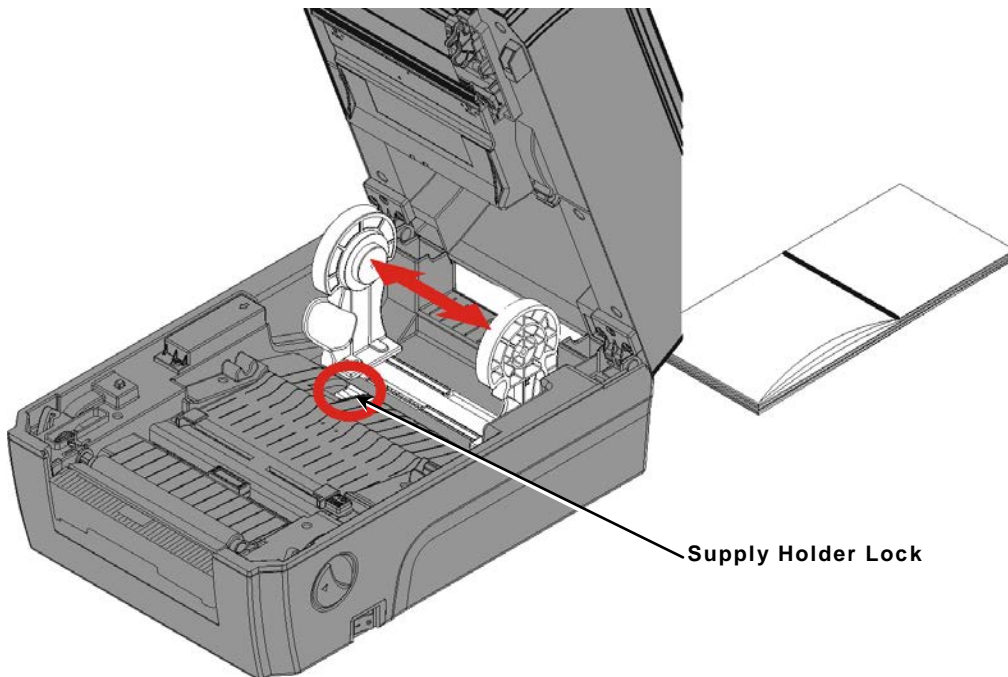

3. Place fan-fold supply (printing side up) into the supply holder. Release the supply holder. The supply holders should fit snugly against the supply. Push the supply holder lock away from you to lock the supply holders in place.
4. Feed the supply into the supply path.

5. Push the supply guide button to move the supply guides until they barely touch the supply.

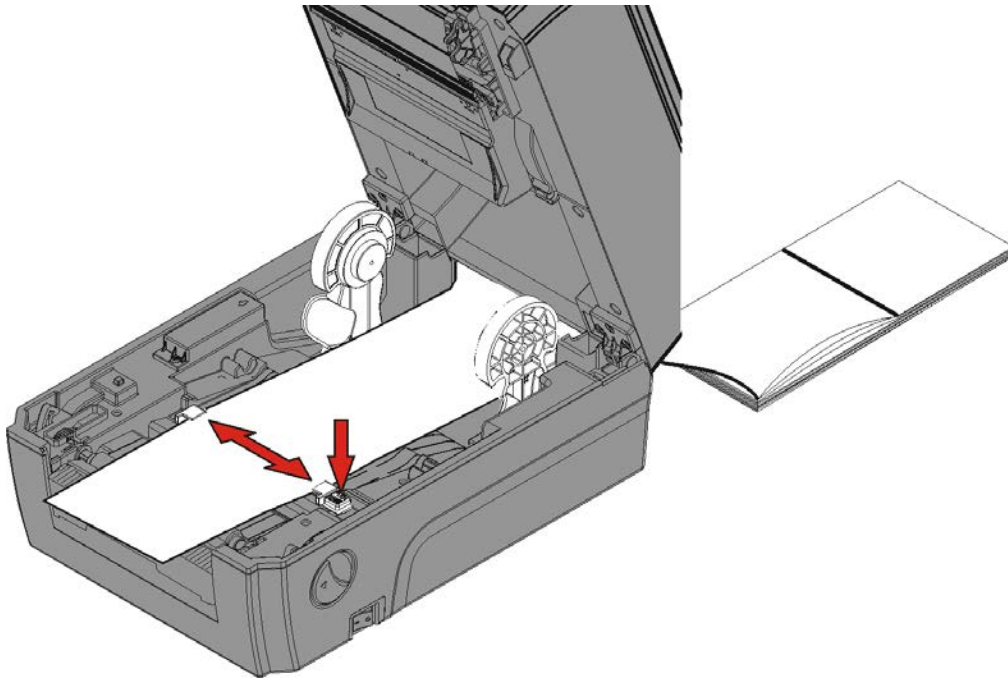

6. Lay the supply over the platen roller.
7. Close the cover until you hear it click into place.
8. Press **Feed** to position the supply under the printhead.

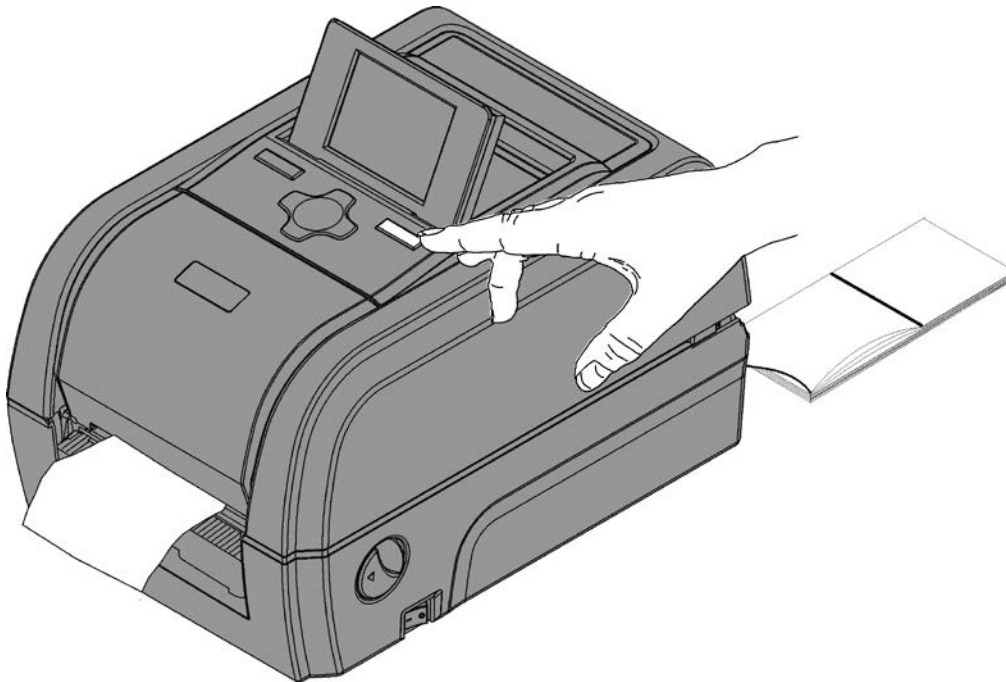

**Note:** If this is the initial printer setup or if you change the supply type (from die cut to black mark, for example), see [“Setting the Printer’s Supply Type/Calibrating Supply.”](#)

## Setting the Printer's Supply Type/Calibrating Supply

Calibrating supply must be done on the initial printer setup, any time the printer has been reset, or whenever the supply type is changed (from die cut to black mark for example) or from tags to labels. The printer automatically calibrates when you set the printer's supply type. The supply type must match the loaded supplies. Supply types include:

- Gap** Use for die cut supply. The supply has a rounded edge. The supply is sensed using the gap between labels.
- Black Mark** Use for black mark supply. Black mark supply has marks on the back of supply for sensing. The supply is sensed using the black marks. Tag supply commonly uses black marks.
- Continuous** Use for non-indexed (no sense mark) supplies. Continuous supply does not have any index marks for sensing or perforations.

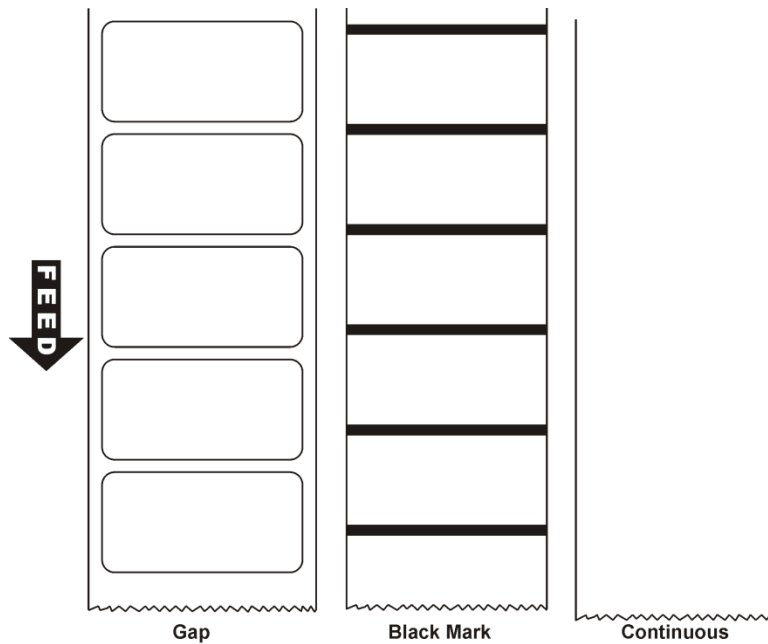

1. From the Main Menu, select **Menu**.
2. Press the navigation button until Media Setup is highlighted. Press **Select**.
3. Press **Select** when Supply Type is highlighted.

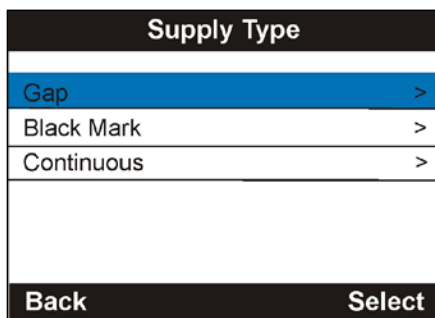

4. Use the navigation button to select your supply type. Press **Select** when finished. The printer displays "Calibrating" while it calibrates the supply.
5. Press **Back** until you see the Main Menu.

## Setting the Feed Mode in Online Mode

---

The printer prints in either continuous or on-demand mode. In continuous mode, the printer prints all the labels in a batch (print job) in one strip. In on-demand mode, the printer prints one label, once that label is removed, the next label prints.

To select the feed mode:

1. From the Main Menu, select **Menu**.
2. Press the navigation button until Online Setup is highlighted. Press **Select**.
3. Press **Select** when Feed Mode is highlighted. Use the navigation buttons to change the feed mode. Press **Select** when finished. The default feed mode is continuous.

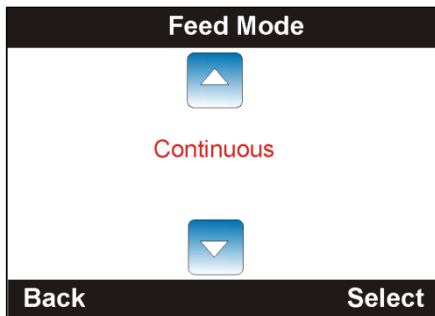

4. Press **Back** until you see the Main Menu.

## Setting the Feed Mode in Offline (Stand-alone) Mode

---

The printer prints in batch mode, none, cutter batch, cutter mode, or peeler mode.

None	Tear off each label after printing.
Cutter Batch	Cut each label.
Cutter Mode	Cut the print job (cuts in strips).
Peeler Mode	Enable peel mode.
Batch Mode	Tear off the print job after printing (tear off in strips).

To select the feed mode:

1. From the Main Menu, select **Menu**.
2. Press the navigation button until Offline Setup is highlighted. Press **Select**.
3. Press **Select** when Feed Mode is highlighted. Use the navigation buttons to change the feed mode. Press **Select** when finished. The default feed mode is batch mode.

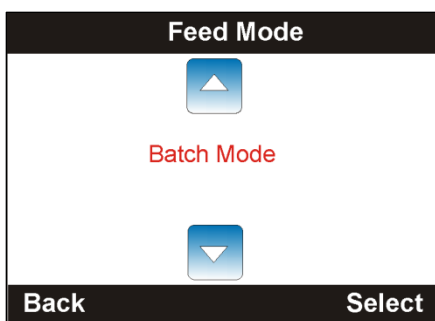

4. Press **Back** until you see the Main Menu.

# LOADING RIBBON

This chapter describes how to load ribbon.

If you are using thermal direct supplies, do not load a ribbon.

Your System Administrator must set the printer to use a ribbon.

## About Ribbons

- ◆ Use your empty ribbon core as the take-up core.
- ◆ An extra take-up core is available by ordering part number 12808745.

1. Turn the cover latches and lift the cover.

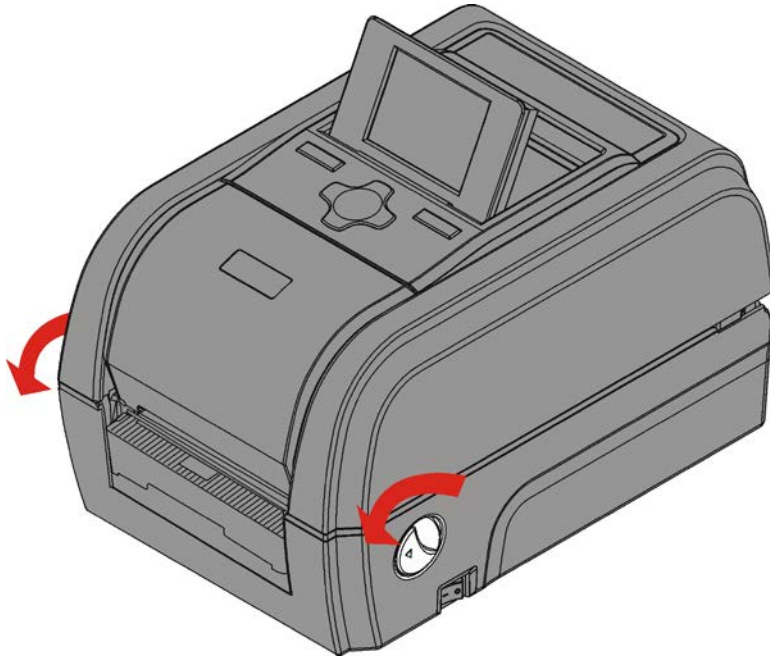

2. Open the ribbon take-up cover and the ribbon cover.

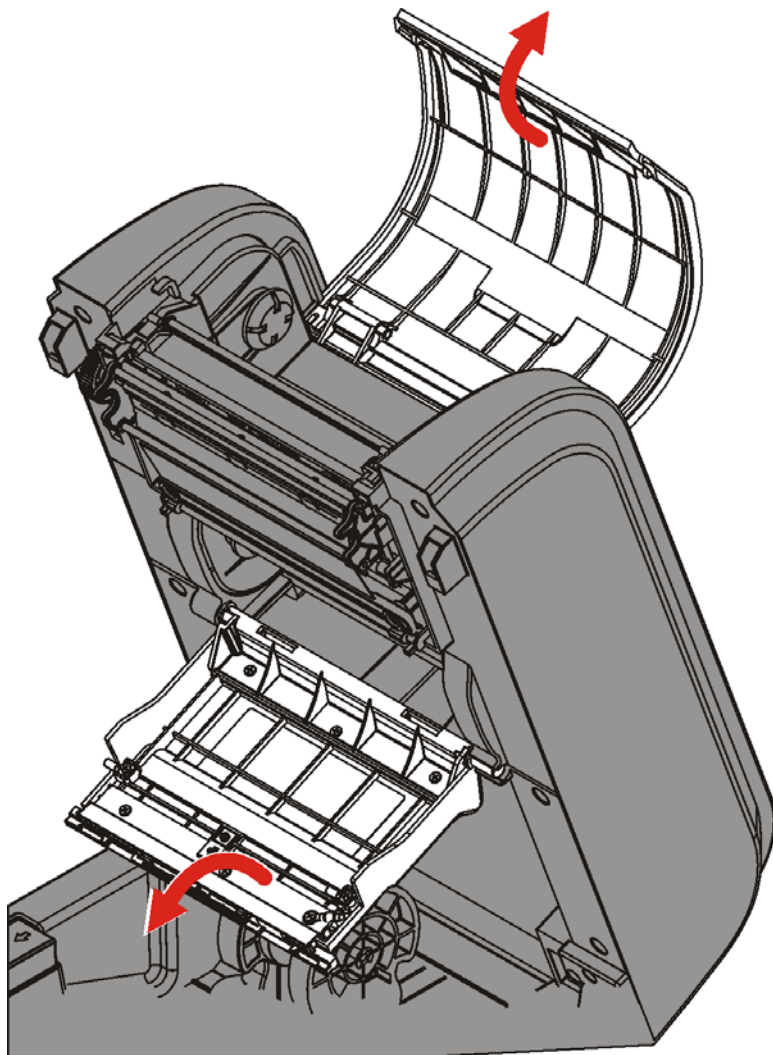

3. Completely insert the ribbon reel into the full ribbon as shown.

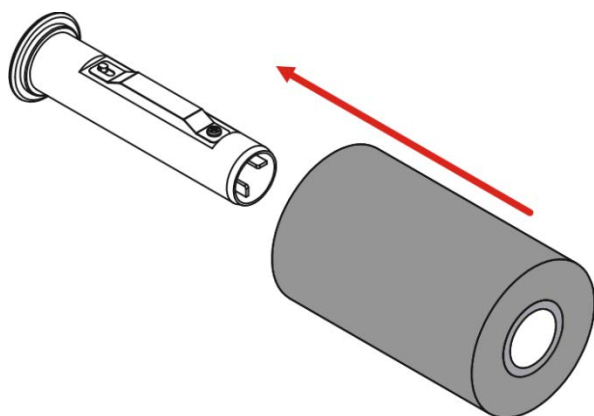



4. Press the open end of the ribbon core into the spring and guide the core until it locks in place. Match the yellow end of the core to the yellow end of the reel.

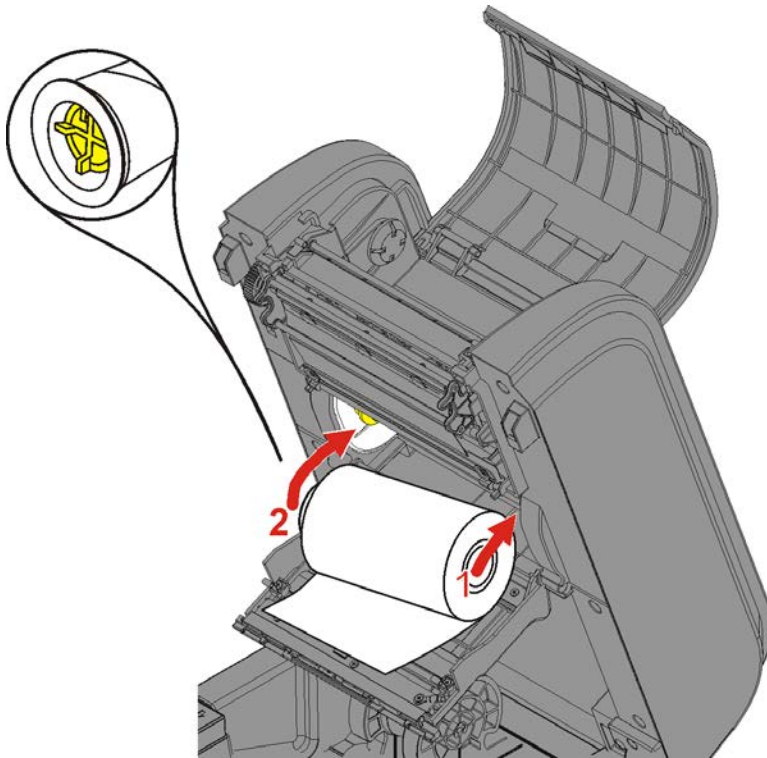

5. Insert the take-up reel into the core.

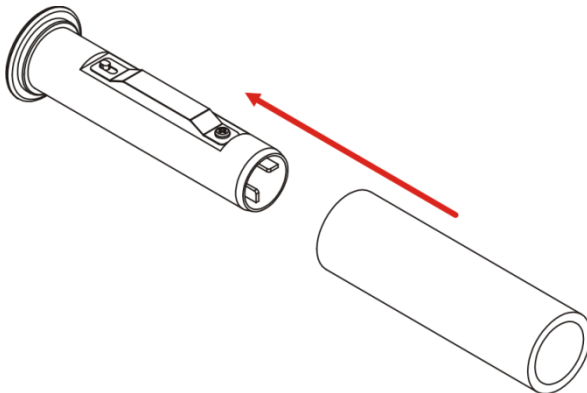

**Note:** Use your empty ribbon core as the take-up core.

6. Press the open end of the take-up core into the spring and guide the core until it locks in place. Match the yellow end of the core to the yellow end of the reel.

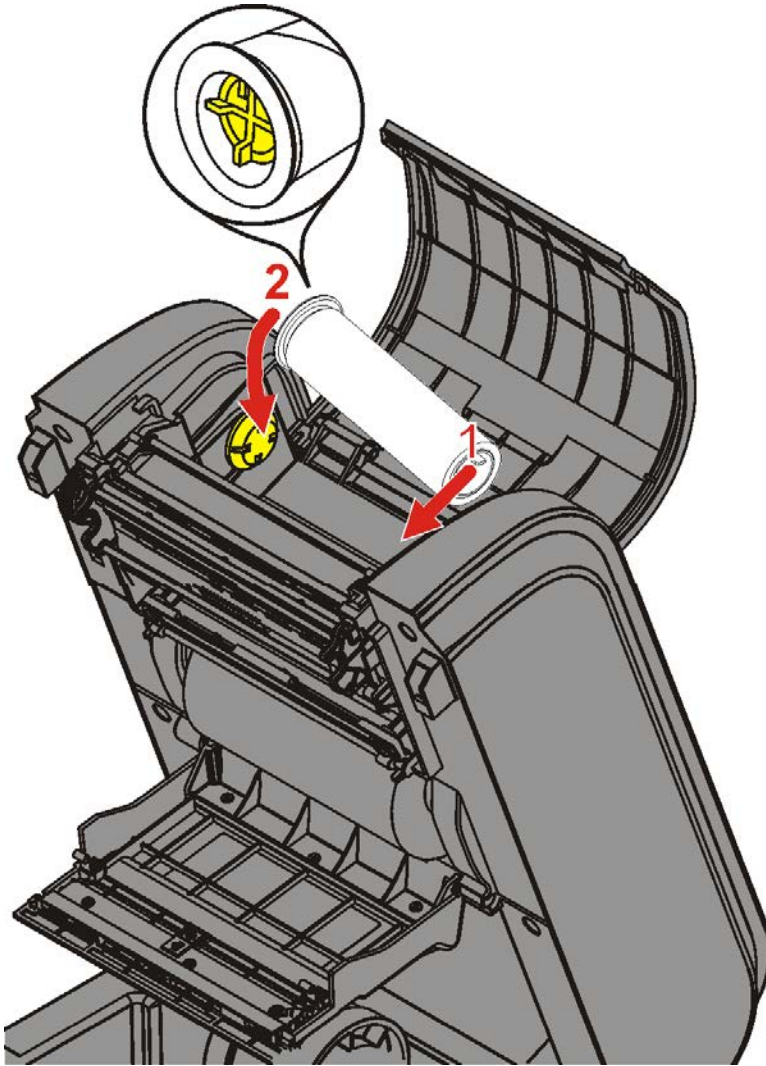

7. Unwind a few inches of ribbon from the full roll with the ink side out.

8. Use the adhesive on the ribbon leader to attach it to the take-up core.

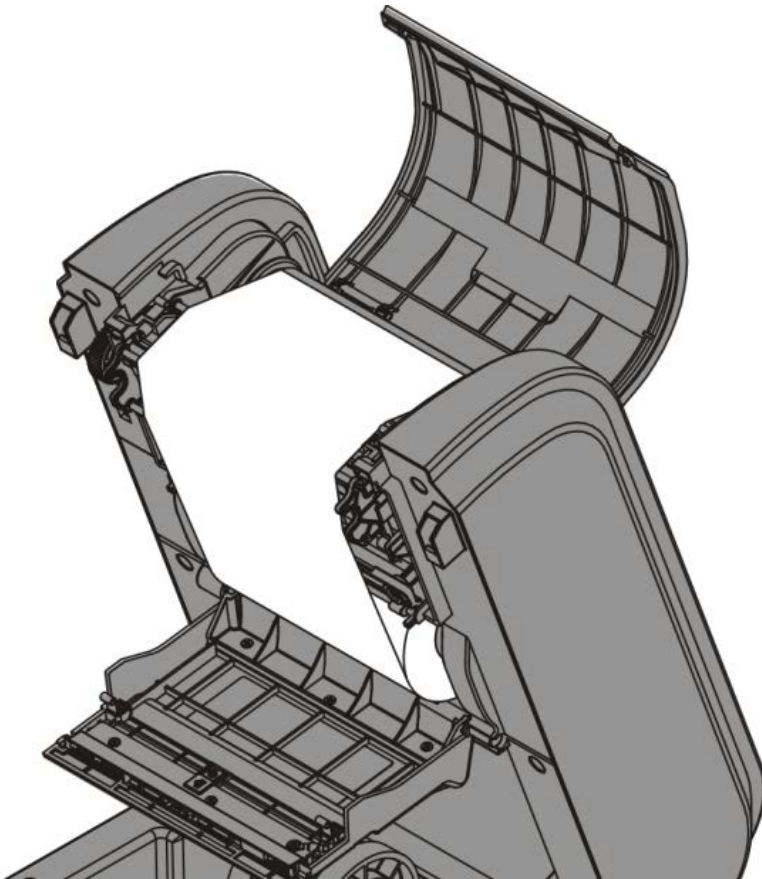

9. Turn the ribbon take-up gear until the leader is past the printhead.

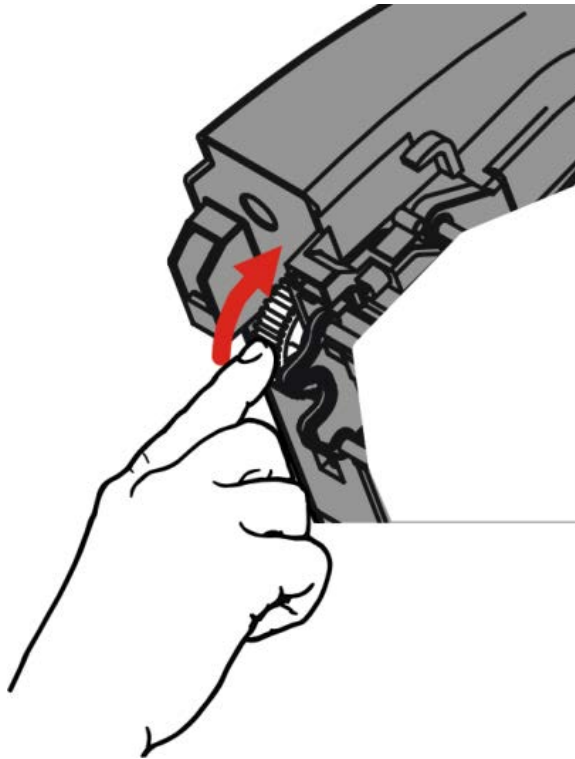

10. Close the ribbon take-up cover and the ribbon cover.
11. Close the cover until you hear it click into place.



The printer operates in either online or offline mode to print labels in one strip continuously or on-demand (prints one label, once that label is removed, the next label prints).

## Online Printing

---

When the printer receives print data, jobs begin printing automatically.

Your System Administrator can use the *Packet Reference Manual* to create the data files necessary to print batches (jobs).

Your System Administrator can use the Printer Management Utility to transfer files to the printer. Refer to either the *Online Mode System Administrator's Guide* or the *Offline Mode System Administrator's Guide* for more information.

Before you print:

- ◆ Load supply.
  - ◆ Connect the printer to a host (a PC or a network).
  - ◆ Make sure the printer is ready to receive data.
1. Turn on the printer. It is ready when you see:

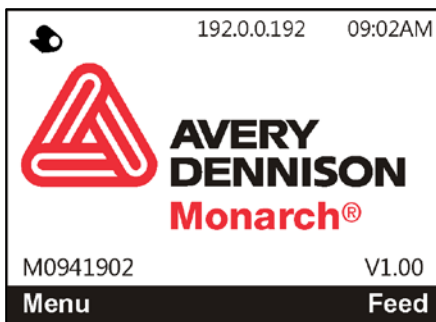

2. Download a format and a batch.
3. The printer prints the batch (print job).

## Offline Printing

---

The printer comes pre-loaded with nine standard formats. Enter data as needed to print these formats.

**Note:** An external USB keyboard or optional scanner is required for data entry.

For information about using these formats, refer to the *Offline Mode System Administrator's Guide*.

## Pausing While Printing

---

1. Press **Pause** to interrupt printing.

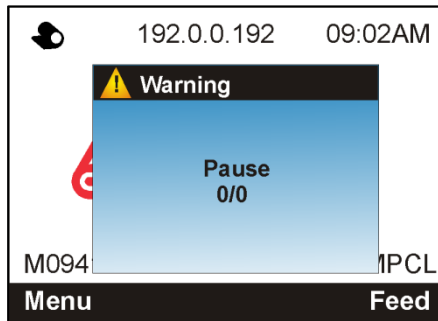

2. Press **Pause** again to resume printing.

## Canceling Printing

---

1. Press **Pause** to interrupt printing.

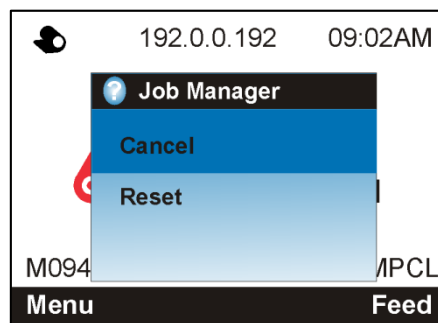

2. Press **Menu**.
3. Press **Feed** to select Cancel. The print job is canceled. Press **Feed** to return to the Main Menu.

This chapter tells you how to

- ◆ clear label jams
- ◆ clean the printer.

**CAUTION:** Do not use sharp objects to clean the printhead or touch the printhead with your fingers. This may damage the printer and require a service charge.

## Clearing Label Jams

---

To clear the jam:

1. Turn the cover latches and lift the cover.
2. If necessary, remove the label roll and ribbon.
3. Remove the jammed labels. You may need to clean adhesive off the platen roller or peel bar. See “Cleaning” for more information.
4. Reload the label roll and/or ribbon.
5. Close the cover until you hear it click into place.

## Cleaning

---

Clean the printhead, peel bar, sensor, and platen roller:

- ◆ when there is any adhesive build-up in the supply path.
- ◆ after adding a new roll of supply.
- ◆ if there are voids or streaking in the print as shown.



Voids



Streaks

1. Turn off the printer, turn the cover latches, and lift the cover.
2. Wait at least one minute for the printhead to cool.

**CAUTION:** Do not use sharp objects to clean the printhead or touch the printhead with your fingers. This may damage the printer and require a service charge.

3. Remove the supply roll and ribbon.
4. Spray the supply path and sensor with compressed air to remove dust and debris.

5. Use a cotton swab moistened with 100% isopropyl alcohol to clean the printhead, peel bar, and platen roller when you see adhesive build-up or after clearing a jammed label.

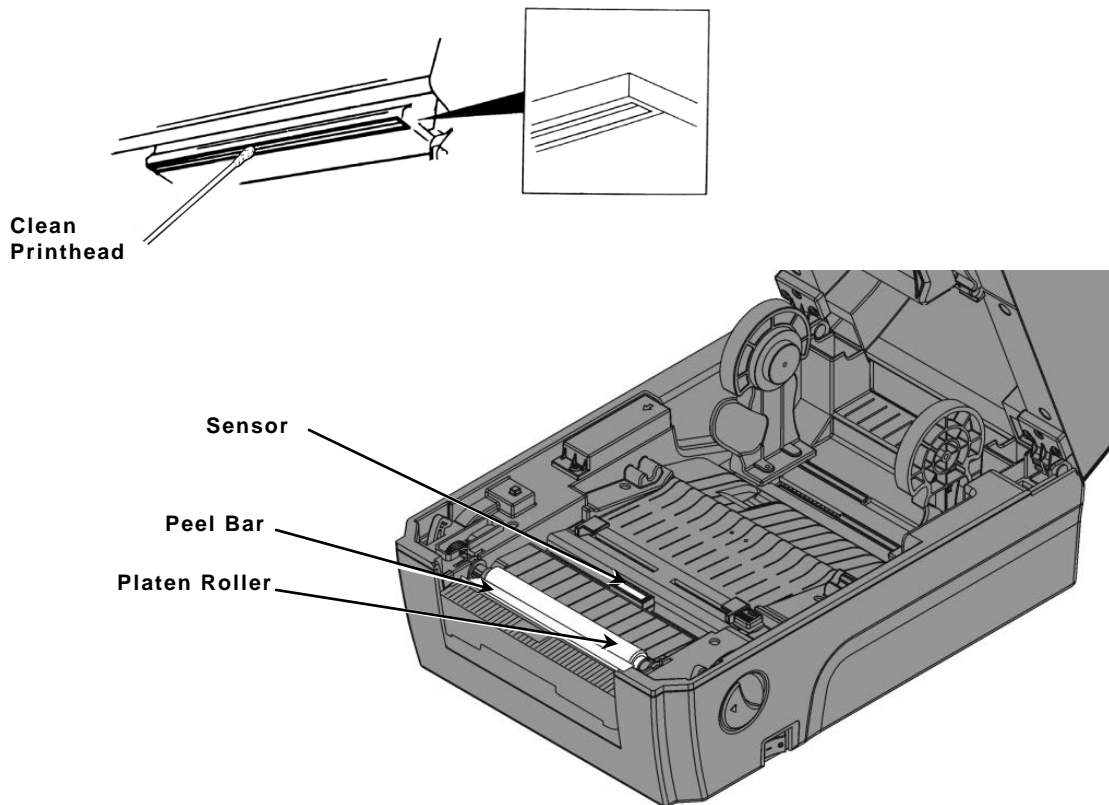

6. Turn the platen roller with your finger to make sure it is clean all the way around.
7. Once the printer is dry, reload the supply and ribbon.
8. Close the cover until you hear it click into place.

## Replacing the Printhead

---

Replace the printhead when it is damaged or worn-out.

**CAUTION:** Static electricity can damage the printhead. Ground yourself by touching metal before touching the printhead.

1. Turn off the printer.
2. Turn the cover latches and lift the cover.
3. Open the ribbon take-up cover and the ribbon cover.



4. Remove the ribbon and supply.
5. Use your thumb to open the printhead tabs. Tabs are located on either side of the printhead. Once both sides are released, the printhead drops down.

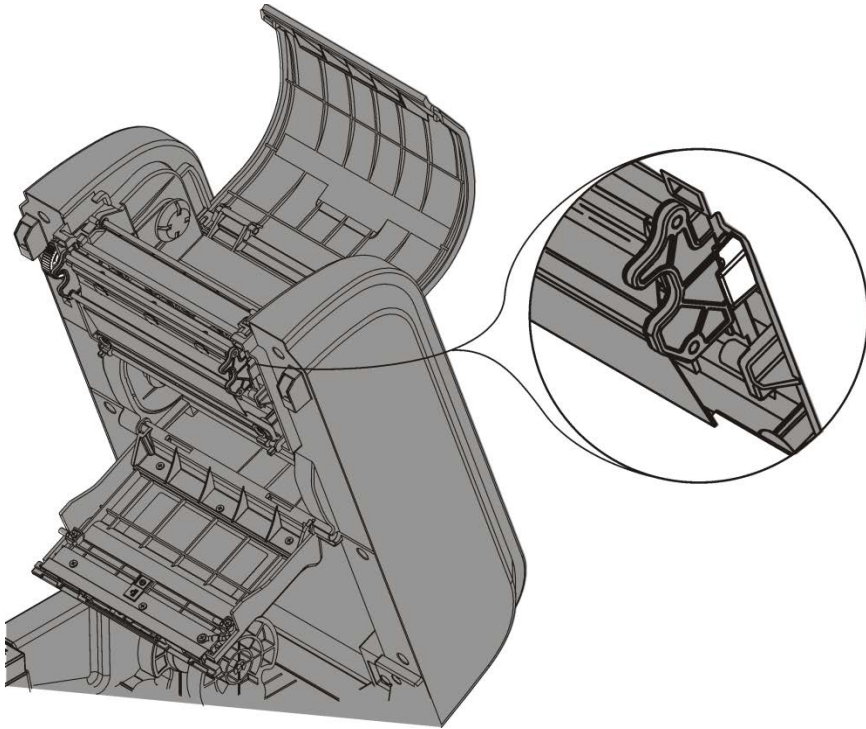

6. Carefully unplug the orange printhead cable and the green grounding wire.
7. Connect the green grounding wire and the orange printhead cable to the new printhead.
8. Align the new printhead bracket's circular indents with the printhead springs.
9. Guide the printhead bracket behind the tabs and into place.
10. Clean the printhead with a cotton swab dipped in 100% isopropyl alcohol.
11. Let the printhead dry and reload supplies and ribbon.
12. Close the ribbon take-up cover and the ribbon cover.
13. Close the cover until you hear it click into place.

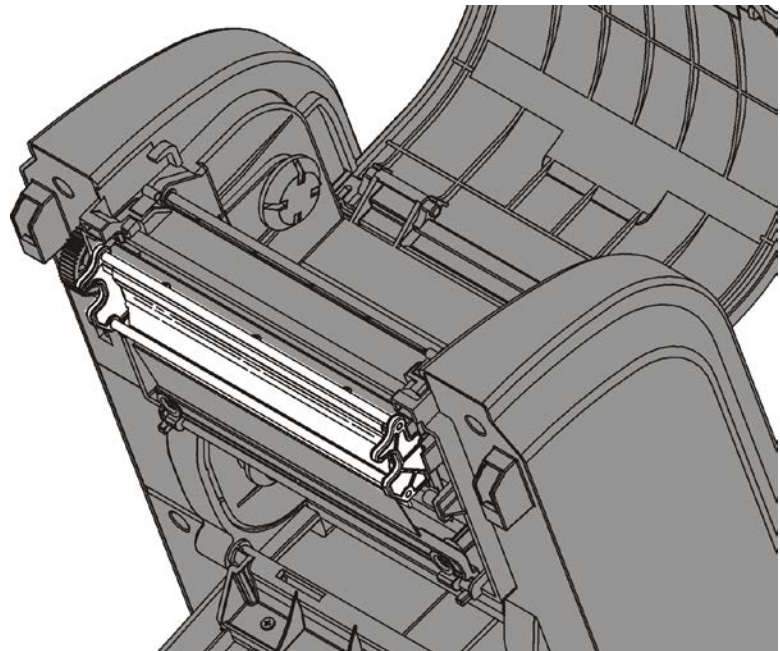

## Replacing the Platen Roller

---

1. Turn off the printer.
2. Turn the cover latches and lift the cover.
3. Remove supply.
4. Press down and completely open the peel door. Then, remove the peel bar. Press against the left side (with the spring) of the peel bar and lift up to remove.
5. Locate the platen roller tabs. Tabs are located on either side of the platen roller.

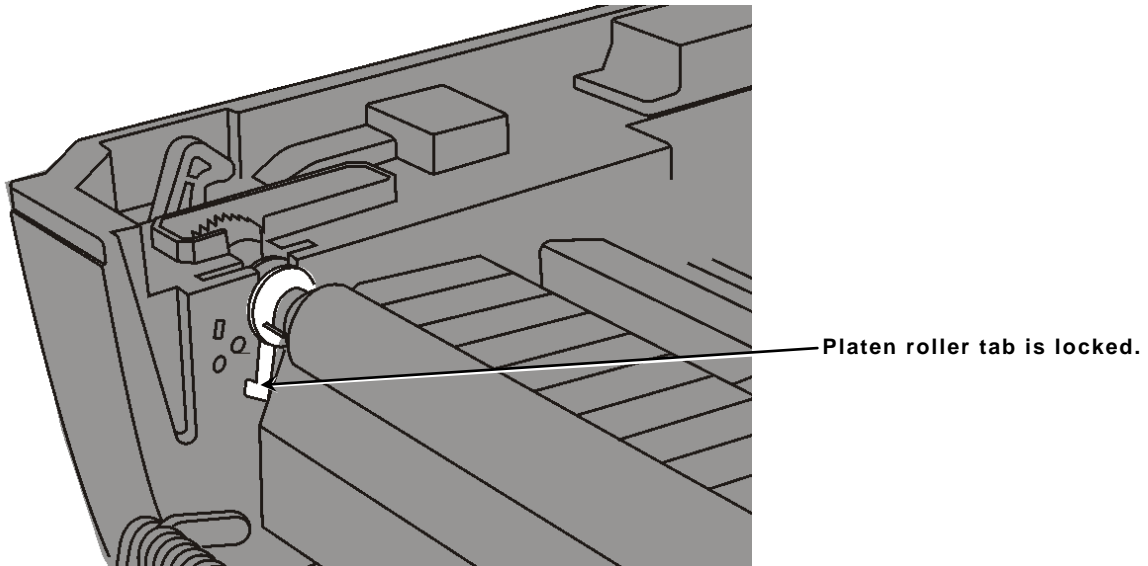

6. Pull on the platen roller tabs and rotate up to unlock.

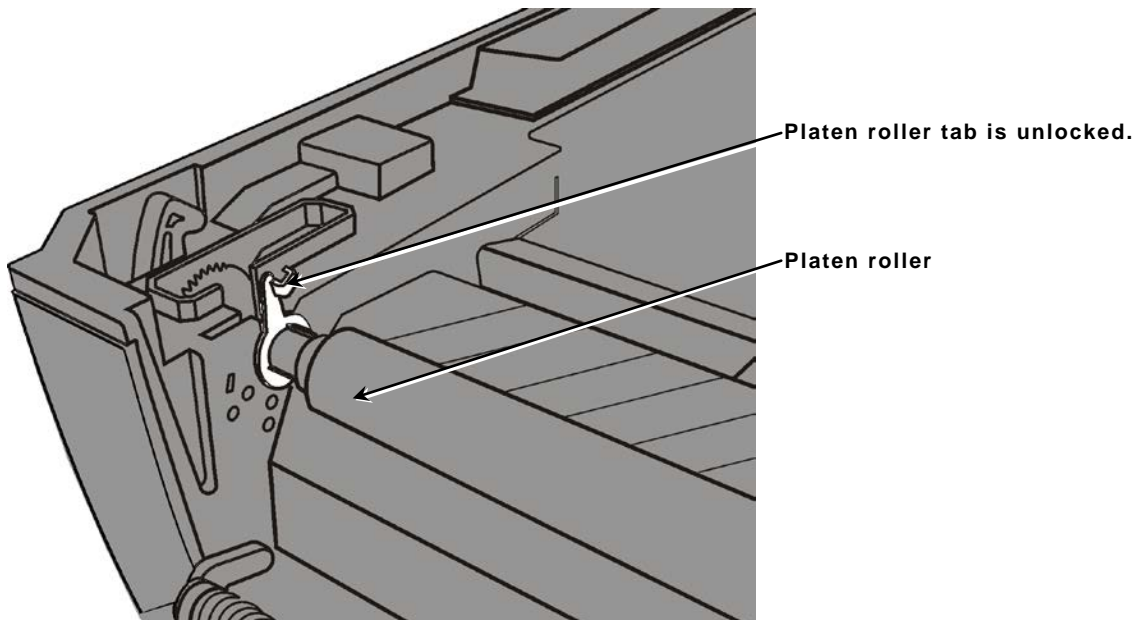

7. Lift up and remove the platen roller.
8. Insert the new platen roller.
9. Lock the platen roller tabs back into place.
10. Reinstall the peel bar if necessary.
11. Reload supply and close the peel door.
12. Close the cover until you hear it click into place.

This chapter explains how to adjust print quality and contains basic troubleshooting information. If you need to call Technical Support, print a test label first. See [“Printing a Test Label”](#) in Chapter 1 for more information.

## Adjusting the Print Quality

Many factors impact print quality: type of supplies, print speed, print contrast, and the printer application. The printer supports both thermal transfer and thermal direct supplies. The type of supply should match the printer’s application.

- ◆ Use premium supplies if you want to print at high speeds.
- ◆ Select the print speed based on desired throughput and print quality. If print quality is more important, reduce the print speed. A lower print speed increases the print quality of labels. If throughput is more important, increase the print speed.
- ◆ If the print quality is too light or too dark, adjust the print contrast.
- ◆ A bar code that is in spec has complete bars, clear spaces, and small alphanumeric characters look complete. An in spec bar code may not look as good as one that is too dark, but it has the highest scan rate.



## Setting the Print Contrast in Online Mode

Having the correct print contrast/density setting is important because it affects bar code scan ability and printhead life.

To change the print contrast:

1. From the Main Menu, select **Menu**.
2. Press the navigation button until Online Setup is highlighted. Press **Select**.
3. Press **Select** when Contrast is highlighted. Use the navigation buttons to select which position to change, then increase or decrease the value. Press **Select** when finished. The print contrast range is -156 to 156 and the default is 0.

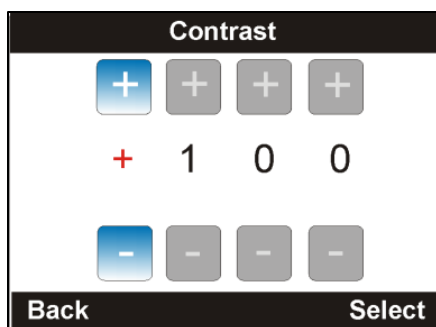

4. Press **Back** until you see the Main Menu.

## Setting the Print Contrast in Offline (Stand-alone) Mode

Having the correct print contrast/density setting is important because it affects bar code scan ability and printhead life.

To change the print contrast:

1. From the Main Menu, select **Menu**.
2. Press the navigation button until Offline Setup is highlighted. Press **Select**.
3. Press **Select** when Contrast is highlighted. Use the navigation buttons to increase or decrease the value. Press **Select** when finished. The print contrast range is 0 to 15 and the default is 8.

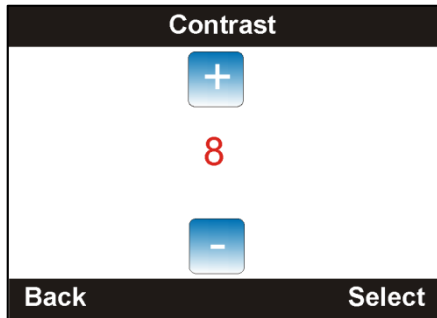

4. Press **Back** until you see the Main Menu.

## Common Problems

Use this information to solve some common problems.

Problem	Action
Does not print. OR "Paper Jam" "No Paper"	Check/load supply and ribbon. Check connection to host. Check printhead density/contrast setting. See " <a href="#">Setting the Print Contrast.</a> " Make sure the printer's supply type is set correctly. See " <a href="#">Setting the Printer's Supply Type/Calibrating Supply</a> " for more information. Clean the printhead.
Does not feed.	Check supply. Check ribbon. Clear jam. Close printhead completely.
Light/Dark printing or voids in print.	Check supply and ribbon. Clean the printhead and platen roller. Check printhead density/contrast and printer speed settings. See " <a href="#">Setting the Print Contrast.</a> " Adjust the platen roller based on supply thickness. See " <a href="#">Adjusting the Platen Roller</a> " for more information.
Serial bar codes print with voids or do not scan.	Check supply and ribbon. Clean the printhead and platen roller. Check printhead density/contrast and printer speed settings. See " <a href="#">Setting the Print Contrast.</a> " Your System Administrator can change the contrast/print speed.

<b>Problem</b>	<b>Action</b>
Ribbon is wrinkled.	<p>Check ribbon.</p> <p>Check supply loading. Make sure the supply guides touch the edges of the supply.</p> <p>Check printhead density/contrast setting. See "<a href="#">Setting the Print Contrast.</a>"</p>
Partially printed data.	<p>Clean the printhead.</p> <p>Resend the batch (print job).</p>
A gray line prints on a blank label.	<p>Clean the printhead and platen roller.</p>
Irregular or unexpected printed data.	<p>Turn off the printer, wait five seconds and turn it back on. (The printer may have entered 'dump mode.')</p> <p>Check the communication settings.</p>
Supply drifts from side-to-side while printing.	<p>Check supply loading. Make sure the supply guides touch the edges of the supply.</p>
Liner is wrapped around platen roller.	<p>Clear the jam.</p> <p>Clean the platen roller.</p>
Blank labels print.	<p>Your System Administrator should check the format. It may not be designed for the loaded supply size.</p> <p>Calibrate the sensor.</p> <p>Clean the supply sensor.</p>
Cutter is not working.	<p>Check for a jam.</p> <p>Make sure the cutter's connector is properly connected.</p> <p>Supply thickness must be less than 0.19mm.</p>

If you cannot fix a problem, call Customer Service.



# SPECIFICATIONS

A

## Printer

---

<b>Height:</b>	7.8 inches (198 mm) <i>with display down</i> 10.0 inches (254 mm) <i>with display upright</i>
<b>Width:</b>	8.8 inches (223 mm)
<b>Depth:</b>	13.1 inches (333 mm)
<b>Weight:</b>	8.9 lb. (4 kg) <i>printer only</i>
<b>Shipping Weight:</b>	12.8 lb. (5.8 kg)
<b>Power Source:</b>	External Power Adapter: <b>Input:</b> AC 100-240V, 2.5 Amps <b>Output:</b> DC 24V, 3.75 Amps
<b>Power Consumption (per printer)</b>	2.9 Amps
<b>Operating Limits:</b>	Thermal Transfer (ribbon): 41° to 95°F (5° to 35°C) Thermal Direct: 41° to 104°F (5° to 40°C) Humidity: 25% to 85% non-condensing <b>Storage:</b> -40°F to 140°F (-40°C to 60°C) Humidity: 10% to 90% non-condensing
<b>Printhead:</b>	Thermal at 4.25 inches (108 mm) wide 203 dpi (8.0 dots per mm) or optional 300 dpi (12 dots per mm)
<b>Printing Method:</b>	Thermal Transfer (ribbon) or Thermal Direct
<b>Print Speed:</b>	1.5 ips (38 mm), 2.0 ips (51 mm), 3.0 ips (76 mm), 4.0 ips (102 mm), 5.0 ips (127 mm), 6.0 ips (152 mm), 7.0 ips (178 mm), 8.0 ips (203 mm) Maximum print speed for 300 dpi is 6.0 ips (152mm) <b>Note:</b> The maximum print speed in peel mode is 3.0 ips (76 mm).
<b>Max Print Area:</b>	4.25 inches x 10.0 inches (108 mm x 254 mm) with 203 dpi 4.17 inches x 10.0 inches (106 mm x 254 mm) with 300 dpi <b>Note:</b> Hold the leading edge of peeled labels when printing on stock longer than six inches.

## Supplies

---

<b>Supply Type:</b>	Labels and tags, perforated or continuous
<b>Supply Widths:</b>	0.75 inches (19mm) minimum 4.4 inches (112mm) maximum
<b>Supply Lengths:</b>	0.12 inch (3mm) minimum for non-peel mode 1.0 inch (25.4mm) minimum for peel mode 6.0 inches (152.4mm) maximum for peel mode 10 inches (254mm) recommended for non-peel mode longer lengths are supported up to 1000 inches (25,400mm) maximum for 203 dpi; and 450 inches (11,430mm) maximum for 300 dpi. Contact your Avery representative for supply recommendations.
<b>Thickness:</b>	0.002 inches to 0.010 inches (0.055mm to 0.254mm)
<b>Wind Direction:</b>	Inside or Outside wound  <b>Note:</b> For inside wound supply, the maximum label length is 6.0 (152.4mm) inches with a 3-inch (76.2mm) core.
<b>Core Diameter:</b>	1.0 inch (25.4mm) to 1.5 inch (38.1mm), cardboard
<b>Internal Label Roll OD:</b>	5.0 inches (127mm)
<b>External Label Roll OD:</b>	8.0 inches (203mm) – requires optional adapter

## Ribbon

---

<b>Ribbon Length:</b>	300 meters (11,811 inches)
<b>Ribbon OD:</b>	2.7 inches (67mm) maximum
<b>Ribbon Core ID:</b>	1.0 inch (25.4mm)
<b>Ribbon Wind Direction:</b>	Ink side out

## Optional Cutter

---

<b>Supply Type:</b>	Tags, perforated or continuous
<b>Tag Widths:</b>	The maximum width using 10 mil (10 point) tags with the cutter is 1.5 inches; with thinner tag supply, the maximum cut width is 4.0 inches (101.6mm) The minimum tag width is 0.75 inches (19mm)
<b>Tag Lengths:</b>	The minimum tag length is 1.0 inches (25.4mm). The maximum tag length is 10.0 (254mm)
<b>Tag Thickness:</b>	up to 10 mil (10 point)
<b>Print Speed:</b>	The maximum print speed with the cutter is 3.0 ips.

## Accessories

---

131688	USB keyboard
13007604	MicroSD Card
12808745	Extra Ribbon Core
131795	203 dpi replacement printhead
131796	300 dpi replacement printhead
131798	Wi-Fi Radio
126894N	External Rewinder – includes a 3.0 inch (76mm) core





**AMERICAS**

170 Monarch Lane  
Miamisburg, OH 45342  
937 865 2123 (direct)  
Tel +800 543 6650  
(8:00 a.m. – 6:30 p.m., EDT)  
Fax +937 865 6663

**ASIA**

No. 7 Chun Ying Street  
Tseung Kwan O Industrial Estate  
New Territories, Hong Kong  
Tel +852 2372 3169  
Fax +852 2995 0014

**WESTERN EUROPE**

1 Thomas Road  
Wooburn Green  
Bucks HP10 0PE  
Tel +(44) 1628 859500  
Fax +(44) 1628 859567

**ASIA PACIFIC****NEW SOUTH WALES**

61 Vore Street  
Silverwater NSW 2128  
Tel +(02) 9647 1833  
Fax +(02) 9647 1914  
Toll free (Outside Sydney only)



Printer and  
Fastener Solutions