

# OPERATOR'S HANDBOOK



TABLETOP PRINTER

1

Each product and program carries a respective written warranty, the only warranty on which the customer can rely. Avery Dennison Corp. reserves the right to make changes in the product, the programs, and their availability at any time and without notice. Although Avery Dennison Corp. has made every effort to provide complete and accurate information in this manual, Avery Dennison Corp. shall not be liable for any omissions or inaccuracies. Any update will be incorporated in a later edition of this manual.

©2015 Avery Dennison Corp. All rights reserved. No part of this publication may be reproduced, transmitted, stored in a retrieval system, or translated into any language in any form by any means, without the prior written permission of Avery Dennison Corp.

#### Trademarks

Monarch® and MPCL are trademarks of Avery Dennison Retail Information Services LLC.  
Avery Dennison® is a trademark of Avery Dennison Corp.



# TABLE OF CONTENTS

<b>GETTING STARTED</b> .....	<b>1-1</b>
Audience .....	1-1
Printer Overview .....	1-1
Connecting the Power Cable .....	1-3
Establishing Communications .....	1-3
Using the Control Panel .....	1-4
Selecting a Function .....	1-4
Exiting a Function .....	1-4
Sleep Delay .....	1-4
Selecting the Printer's Language .....	1-5
Printing a Test Label .....	1-5
<b>LOADING SUPPLIES</b> .....	<b>2-1</b>
Using String Tags .....	2-1
Loading Labels or Tags .....	2-2
For String Tags .....	2-4
For Fan-Fold Labels .....	2-4
Loading Labels for Peel Mode (Optional) .....	2-7
Loading Labels for Peel Mode with Liner Take-Up (Optional) .....	2-13
Removing a Full Liner Take-Up Roll .....	2-15
<b>LOADING RIBBON</b> .....	<b>3-1</b>
About Ribbons .....	3-1
<b>PRINTING</b> .....	<b>4-1</b>
About RFID Supplies .....	4-1
Printing .....	4-1
Pausing While Printing .....	4-2
Canceling Printing .....	4-2
Repeating a Batch .....	4-2
<b>CARE &amp; MAINTENANCE</b> .....	<b>5-1</b>
Clearing Label Jams .....	5-1
Cleaning .....	5-2
Replacing the Printhead .....	5-3

<b>TROUBLESHOOTING</b> .....	<b>6-1</b>
Adjusting the Print Quality .....	6-1
Setting the Print Contrast .....	6-1
Adjusting the Printhead Pressure Dials .....	6-2
Troubleshooting .....	6-3
Error Messages .....	6-4
<b>SPECIFICATIONS</b> .....	<b>A-1</b>
Printer .....	A-1
Supplies (Media) .....	A-2
Ribbon .....	A-2

# GETTING STARTED

The Avery Dennison® Monarch® Tabletop Printer 1 prints on thermal transfer (ribbon) and thermal direct labels or tags. The printer prints labels continuously (in one strip) or on-demand (one label at a time). You can print on aperture, die cut, black mark, or continuous (non-indexed) supplies.

This chapter explains how to:

- ◆ connect the power cord and communication cable.
- ◆ use the printer's control panel.

A power cord and ribbon take-up core (may already be on take-up reel) are included. Keep the box and packaging material in case the printer ever needs repair.

**Note:** Review the *Safety Document* included with your printer and the Regulatory information found on our Web site.

## Audience

---

This *Operator's Handbook* is for the person who prints and applies labels. For advanced printer setup (configuring the printer, changing RFID settings), refer to the *System Administrator's Guide*.

## Printer Overview

---

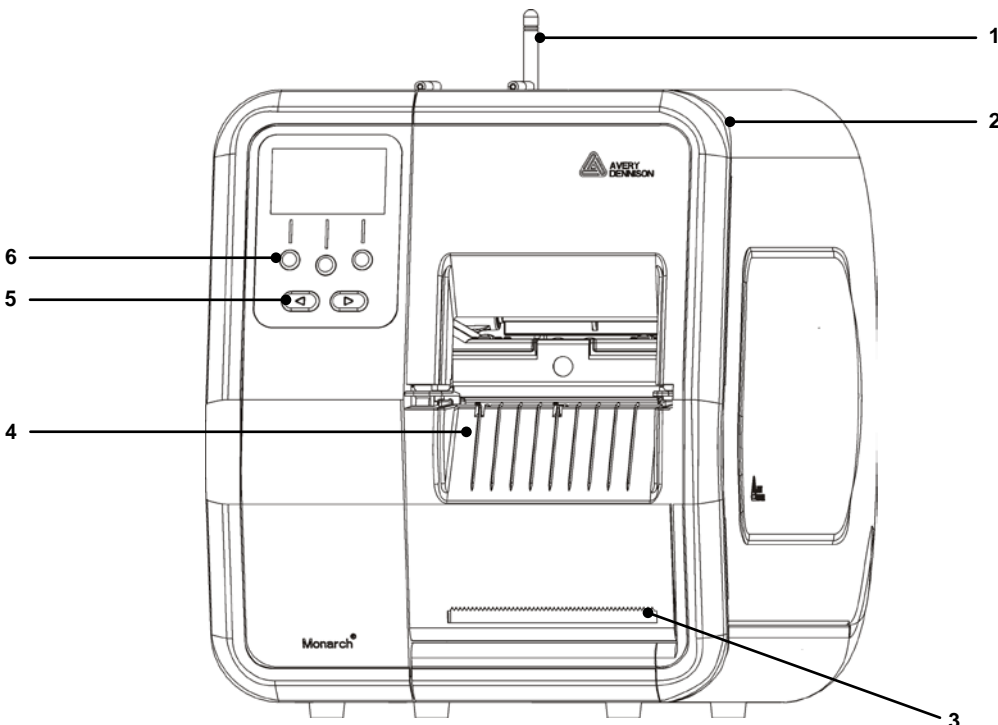

1	Antenna, if installed	4	Exit Cover
2	Cover	5	Navigation Buttons
3	Liner Tear Edge	6	Function Buttons

User touch parts are red.

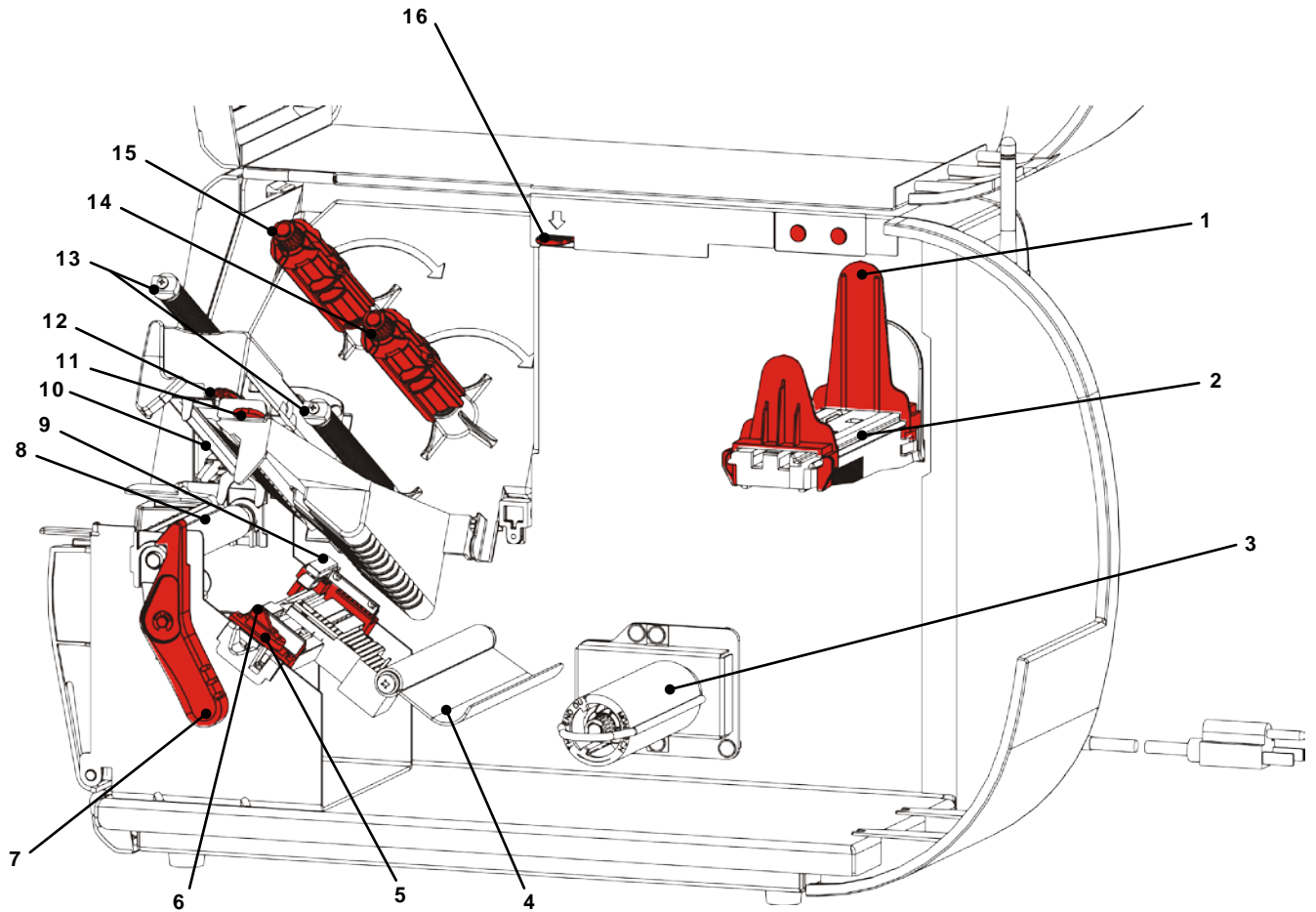

1	Roll Guides	9	Die Cut Sensor
2	Supply Holder	10	Printhead
3	Liner Take-up Reel (optional)	11	Deflector Tab
4	Tension Bar	12	Printhead Tab
5	Supply Guides	13	Ribbon Guides
6	Supply Lever	14	Ribbon Reel
7	Printhead Latch	15	Ribbon Take-up Reel
8	Platen Roller	16	Printhead Release

## Connecting the Power Cable

---

The power supply automatically switches between 115V or 230V. No operator settings are required.

1. Plug the power cable into the connection located on the back of the printer. Plug the cable into a grounded electrical outlet.

**Note:** Only use a certified power cable with proper voltage for the country of installation. In facilities with power spikes/outages, we recommend using a certified surge protector with proper voltage for the country of installation.

2. Turn on the printer. Press ( I ) to turn on and ( O ) to turn off the printer.

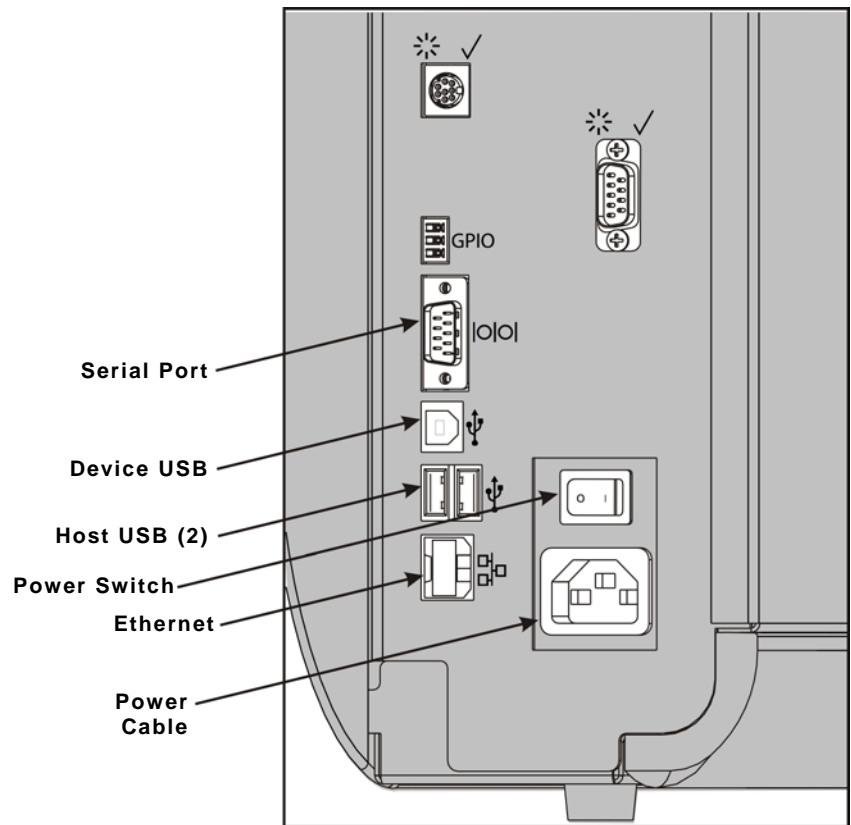

## Establishing Communications

---

Before you print, make sure supply is loaded, the printer is connected to a host (a PC or a network) and is ready to receive data.

The printer can establish communications using the serial port, device USB port, Ethernet port, or wirelessly (optional). Before the printer can accept print jobs from the host, you must:

- ◆ connect the communication cable between the printer and host or connect wirelessly.
- ◆ set the communication values on the printer to match those at the host (System Administrator only).

Ask your System Administrator which communication method to use.

### For Serial Communications:

Secure the serial cable with the connecting screws. Make sure the printer's communication values match those at the host. The printer's default values are 9600 Baud, 8 bit data frame, 1 stop bit, no parity, and DTR flow control.

### For USB Communications:

The printer has three USB 2.0 ports. Drivers are available on our Web site.

Device port      Connect to a PC and transfer data

Host ports (2)    Connect external devices, such as a keyboard, scanner, or thumb drive

## For Ethernet Communications:

If you are using Ethernet communications, you can monitor the status using the LEDs as shown:

**Top LED:**      Blinking green      network activity/receiving data

**Bottom LED:**    Orange      a connection is present

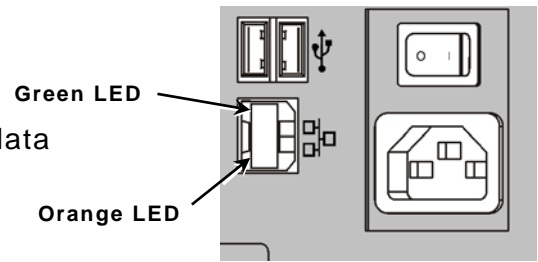

## Using the Control Panel

---

The control panel has an LCD display and five buttons. The top three buttons are function buttons, which vary depending on the task shown above the button. The two bottom buttons are navigation buttons; use these to scroll through menus.

The LCD

- ◆ uses a red background when immediate attention (jam or error) is required. For more information see Chapter 6 "[Diagnostics & Troubleshooting](#)."
- ◆ uses a green background when the printer is active (printing or receiving data).
- ◆ uses a white background when viewing menu prompts, printer settings, button functions, etc.

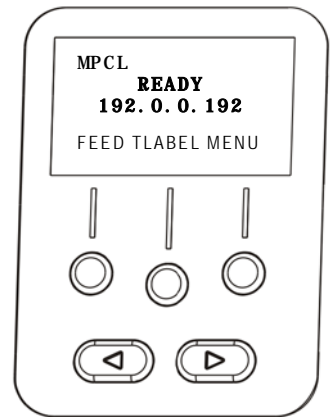

### Selecting a Function

Your System Administrator can access the MENU to configure the printer.

- ◆ Press **MENU**.
- ◆ Press **←** or **→** to see the menu options.
- ◆ Press **SELECT** when you see the menu option you need.

### Exiting a Function

There are two ways to exit an option. Pressing **BACK** once returns to the previous menu and saves any changes. Pressing **CANCEL** exits to the previous menu; however, changes are not saved.

### Sleep Delay

When the printer is idle for a selected period of time, it goes into sleep mode to conserve power. Your System Administrator can adjust the Sleep Delay setting. The default setting is 60 minutes. The printer wakes from sleep mode when it receives a print job, a button is pressed, or the printhead is opened or closed.



## Selecting the Printer's Language

To change the printer's menu language:

1. Press **MENU**.
2. Press **←** or **→** until you see **SETUP**. Press **SELECT**.
3. Press **←** or **→** until you see **LANGUAGE**. Press **CHANGE**.
4. Press **←** or **→** until you see the language you need, then press **SET**.
5. Press **BACK** until you see "Ready," then press **SELECT**.

## Printing a Test Label

---

Before you call Technical Support, print a test label.

1. From the Main Menu select **TLABEL**.
2. Press **←** or **→** to scroll through the test label options:

### Printer Information

Contains generic information, including inch counts and printhead resolution.

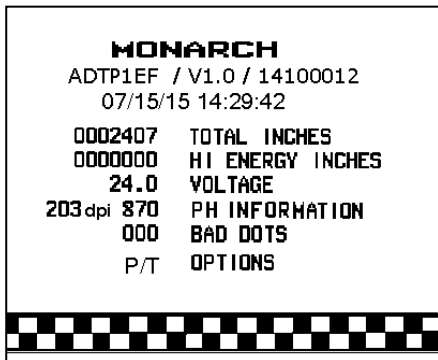

### MPCL Label

Contains the printer's MPCL packet configuration.

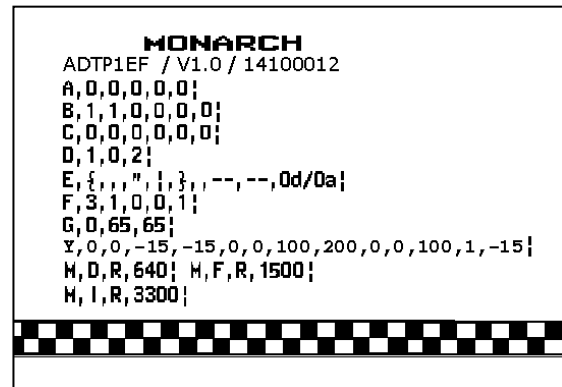

3. When you see the test label you need, press **PRINT**. Press **BACK** to return to the previous menu without printing a test label.



# LOADING SUPPLIES

This chapter describes how to load:

- ◆ a roll of labels, tags, or string tags
- ◆ fan-fold supply
- ◆ peel mode supplies with and without internal liner take-up.

Ask your System Administrator which type of supply to use:

**Thermal Direct**          heat activated supplies that do not use a ribbon for printing

**Thermal Transfer**      standard supplies that require a ribbon for printing

**Note:** Your System Administrator must set the printer for the correct supply type. If you are using thermal direct supplies, do not load a ribbon.

## Using String Tags

Follow these guidelines for string tags:

- ◆ maximum print speed is 6.0 inches per second.
- ◆ thermal direct printing and a cutter are not supported.
- ◆ A non-print zone of 0.250 inches (6.4 mm) exists on the string side of the tag.

## Loading Labels or Tags

---

1. Open the cover.

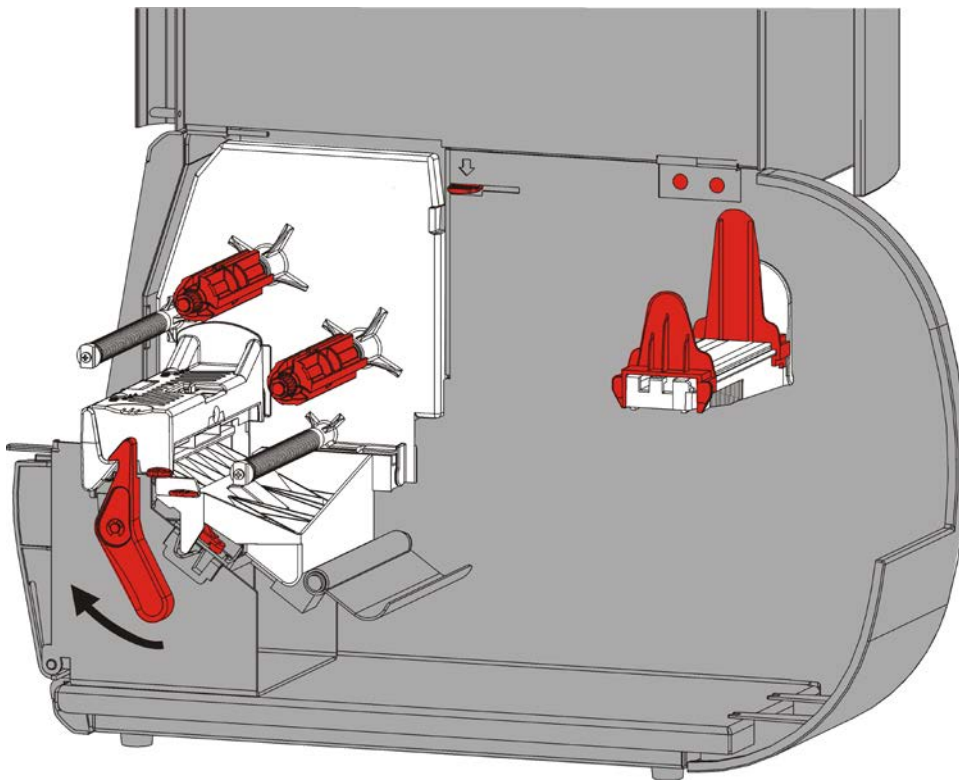

2. Turn the printhead latch to unlock the printhead.



3. Lift the printhead assembly until it locks into place.

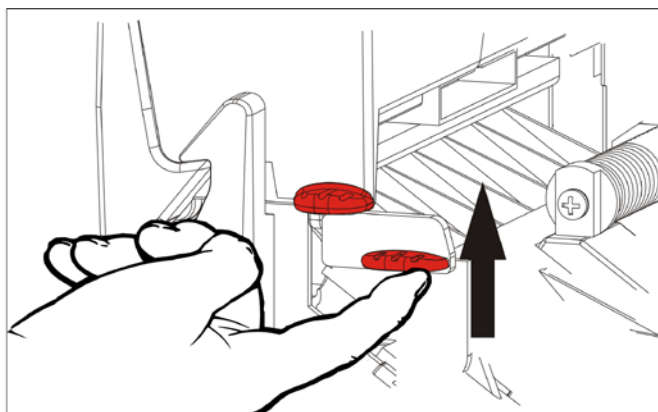

4. Adjust the roll guides to fit your supply roll. The supply roll must move freely.

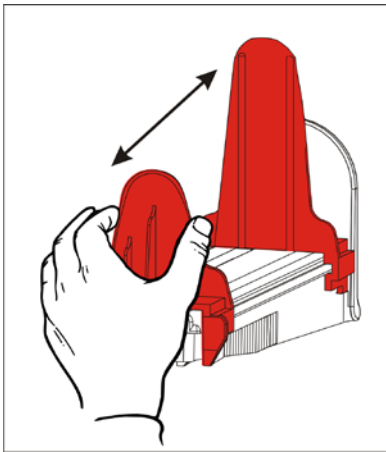

5. Place rolled supply on the supply holder. Label supply can unroll from the top or the bottom; tag supply should unroll from the bottom only (tag rolls are wound face in).

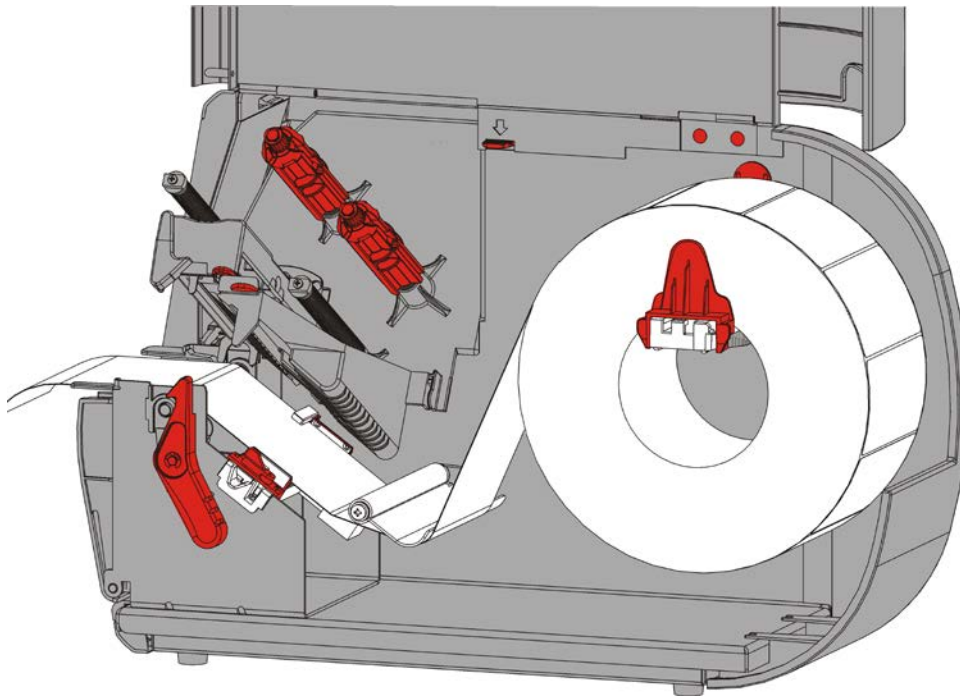

6. Feed the supply under the tension bar and into the supply path.

## For String Tags

Shake the roll of string tags down to untangle the roll. Make sure the strings face out.

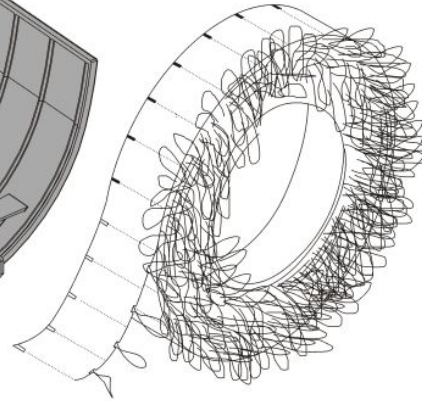
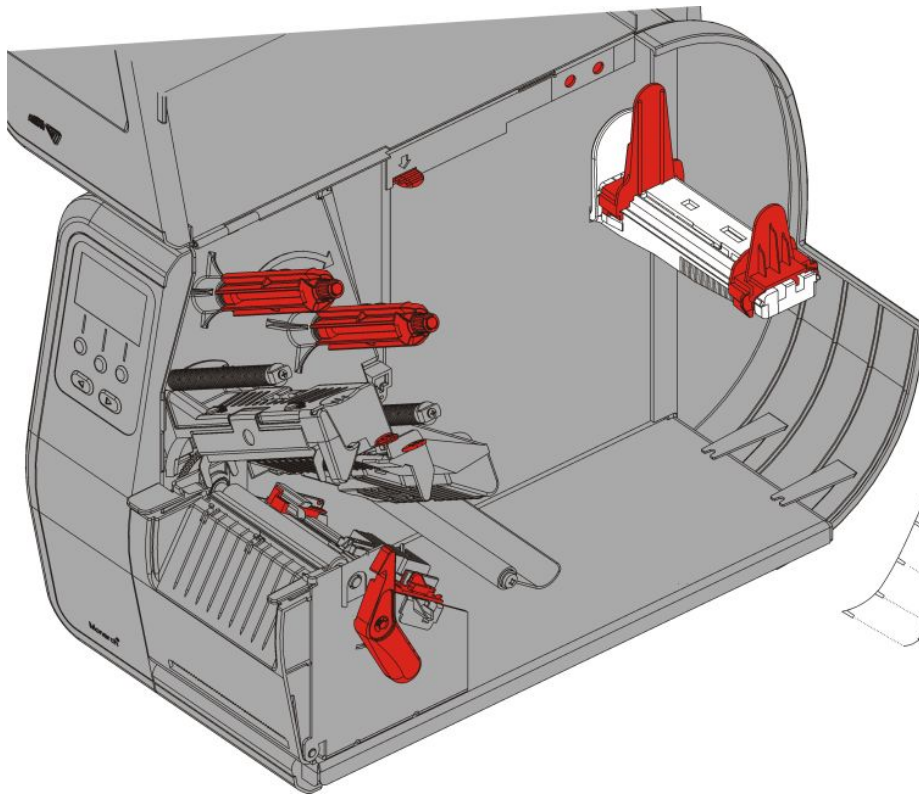

## For Fan-Fold Labels

Place a fan-fold supply stack behind the printer, label side facing up. Lay the label strip over the supply holder.

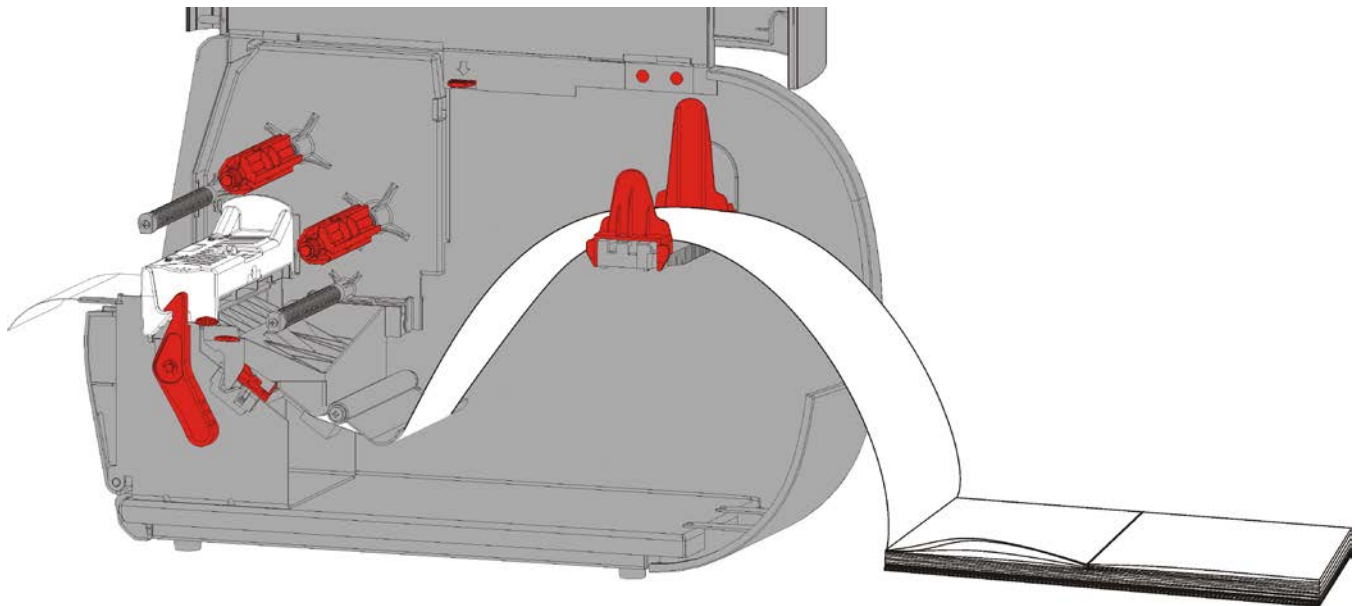

7. Turn the supply lever to unlock the supply guides.

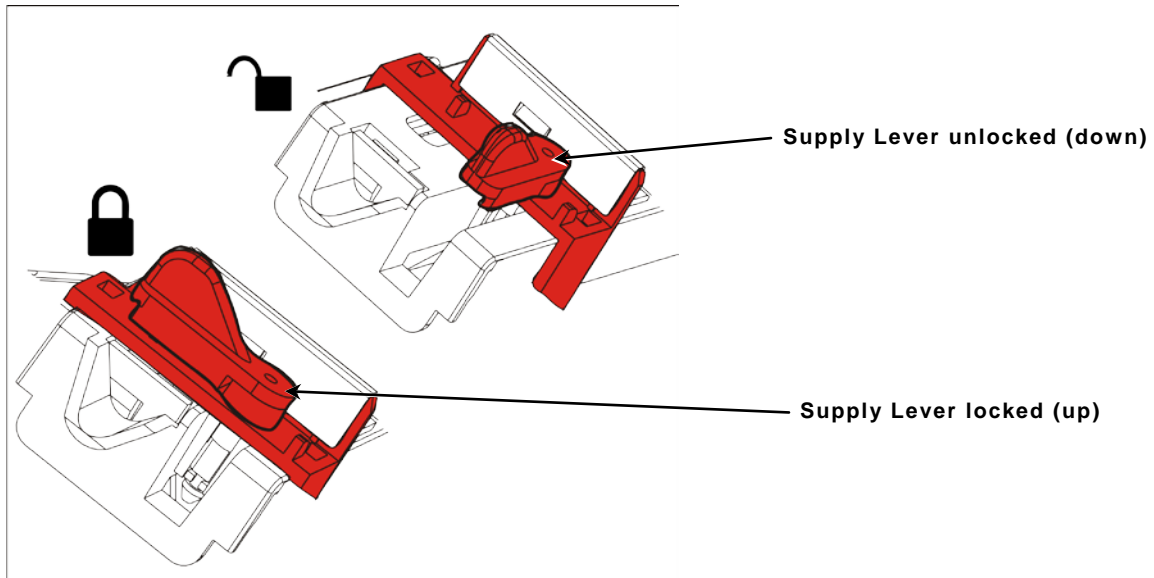

8. Feed the supply through the supply path so a few inches extend past the front of the printer. Tuck the supply under the nibs and die cut sensor.

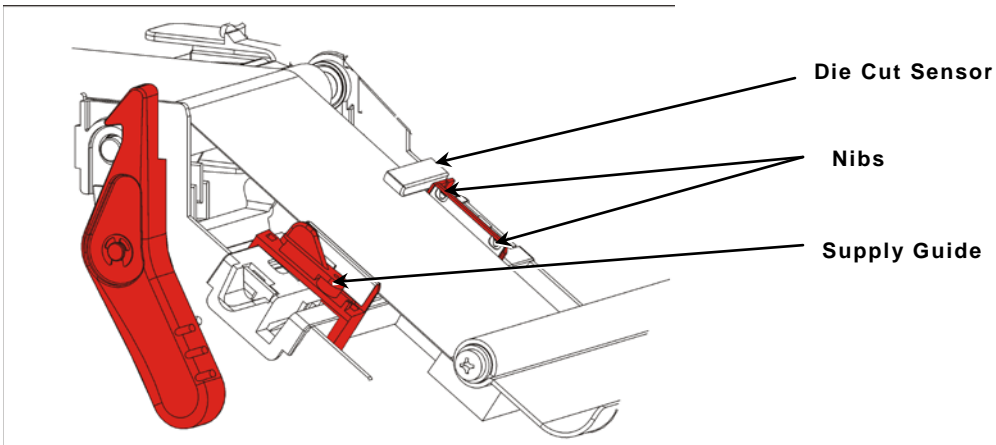

9. Adjust the supply guides so they barely touch the supply. Turn the supply lever up to lock it in place.

10. Push the printhead release.

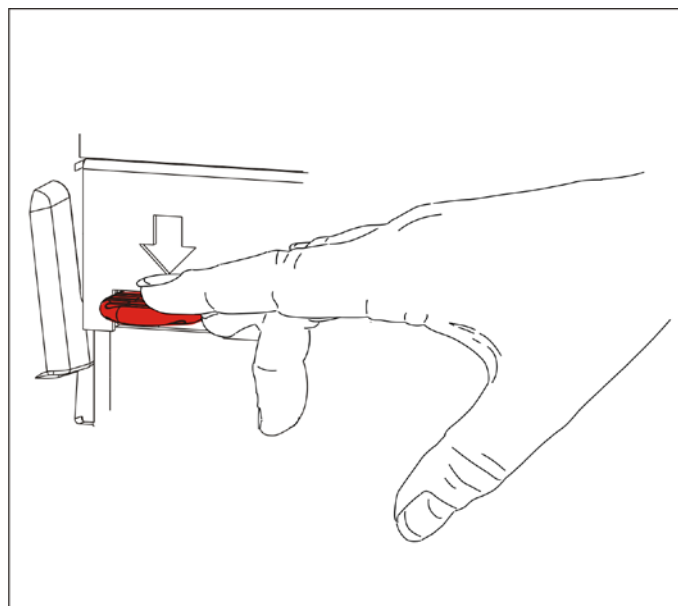

11. Close the printhead assembly until you hear it click into place.

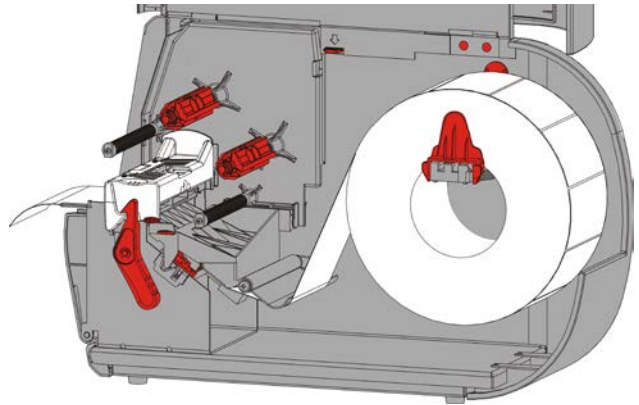
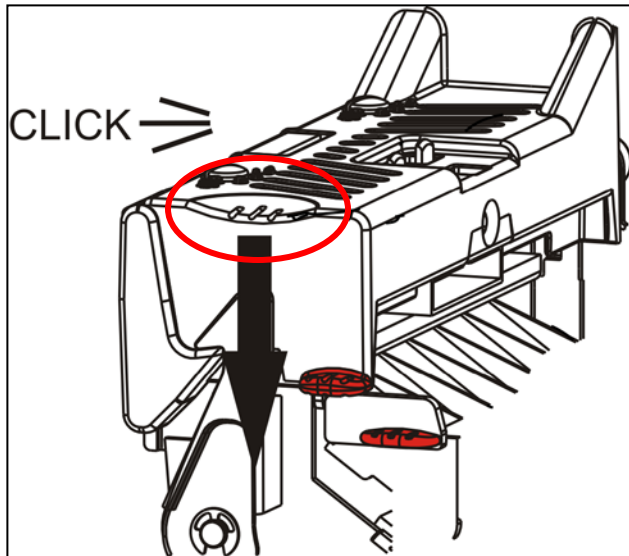

12. Close the cover.

13. Press **FEED** to position the supply under the printhead.

You may need to adjust the printhead pressure dials depending on the width of your supply. See "[Adjusting the Printhead Pressure Dials](#)" for more information.

**Note:** Leave the printhead unlatched if the printer will be unused for extended periods of time. This prevents platen roller damage which can cause a jam.



## Loading Labels for Peel Mode (Optional)

In peel mode, the printer separates the liner from the label. This is known as on-demand mode printing. The next label is not printed until the completed one is removed from the printer or when you press **FEED**. The display shows "Printing X of Y" until all labels print.

- ◆ minimum feed length is 1.5 inches.
- ◆ maximum speed is 8.0 inches per second.
- ◆ use non-perforated supplies.

**Notes:** Your System Administrator must set the printer for on-demand mode and the correct supply type.

1. Open the cover.

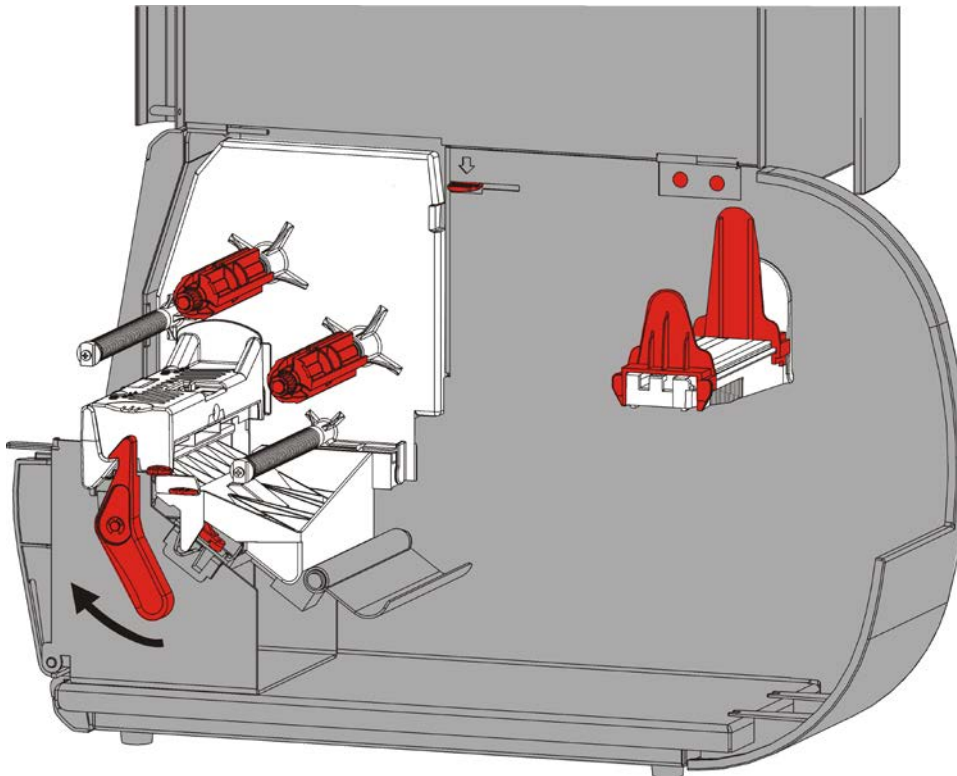

2. Turn the printhead latch to unlock the printhead.



3. Lift the printhead assembly until it locks into place.

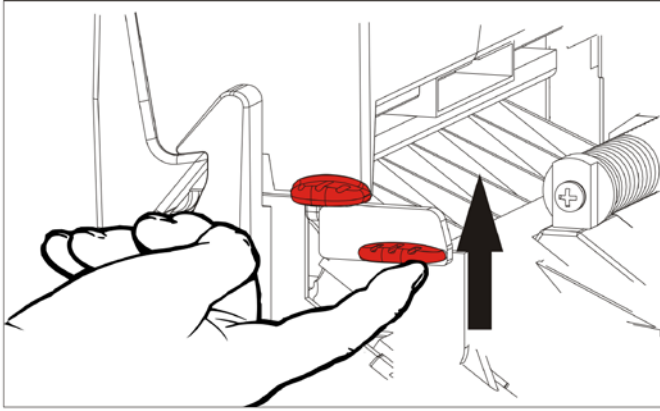

4. Adjust the roll guides to fit your supply roll. The supply roll must move freely.
5. Place rolled supply on the supply holder. Label supply can unroll from the top or the bottom.

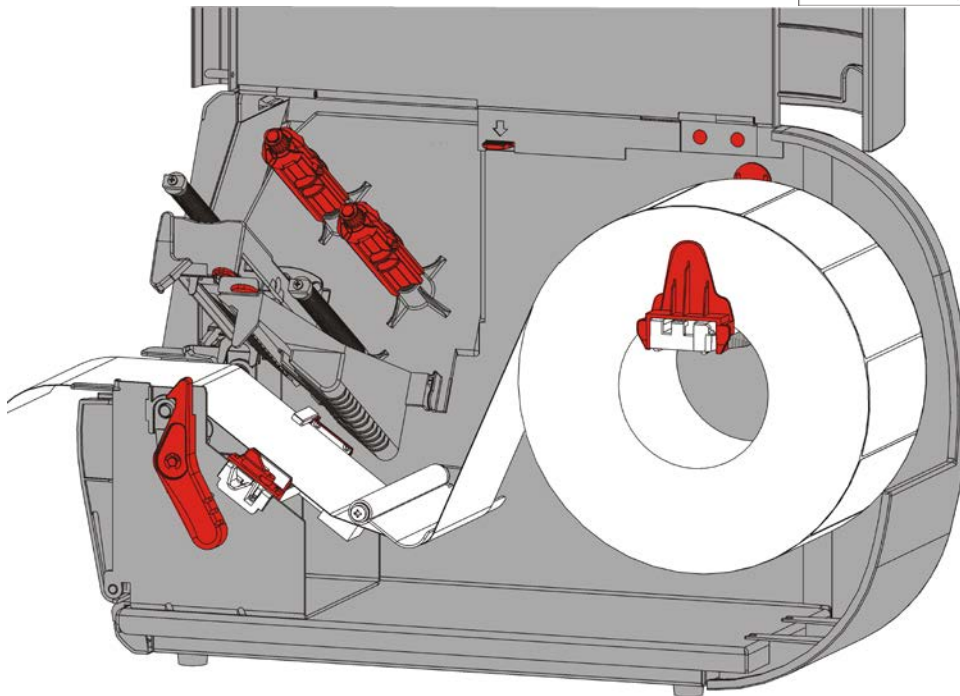
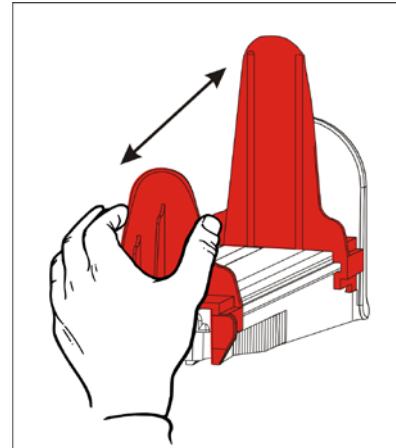

6. Feed the supply under the tension bar and into the supply path.

7. Turn the supply lever to unlock the supply guides.

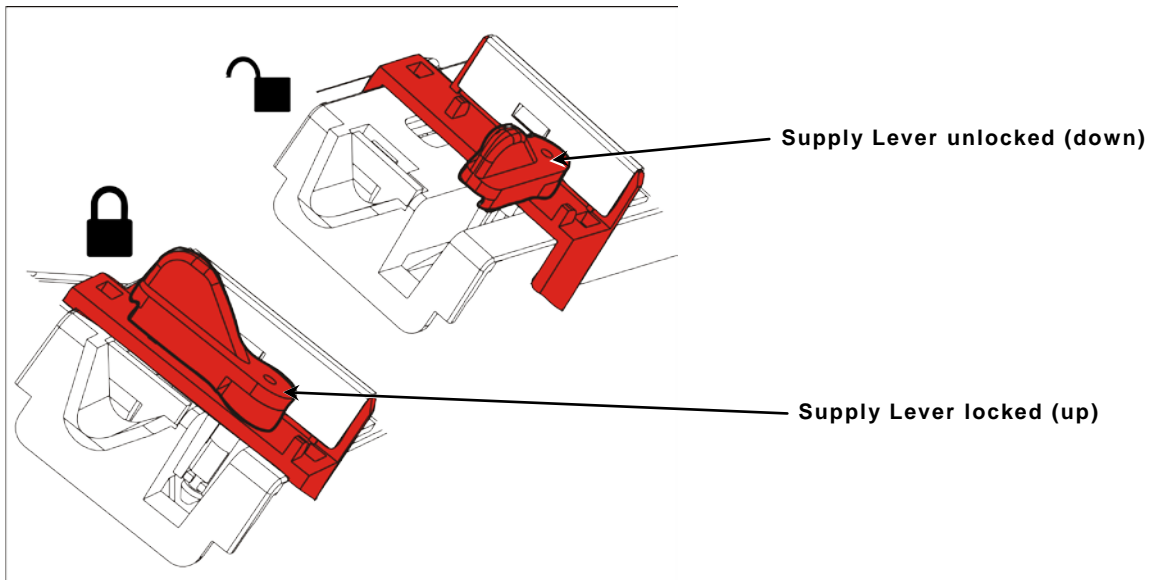

8. Feed the supply through the supply path so a few inches extend past the front of the printer. Tuck the supply under the nibs and die cut sensor.

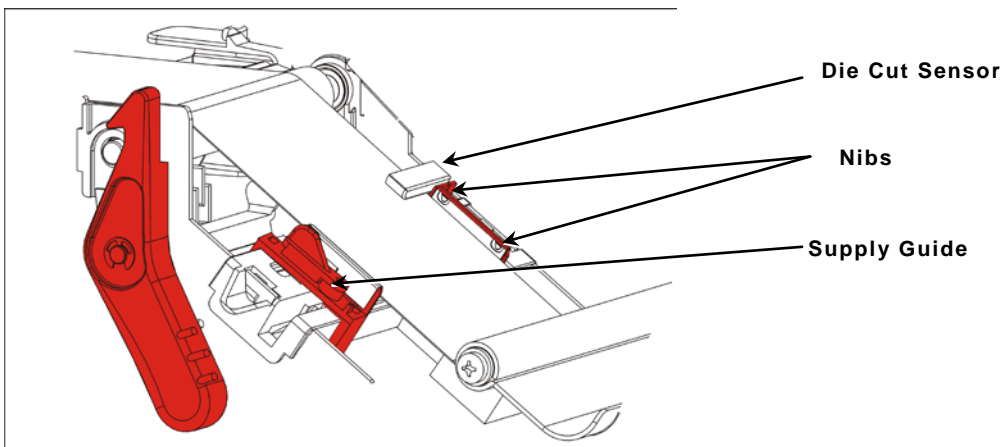

9. Adjust the supply guides so they barely touch the supply. Turn the supply lever up to lock it in place.

10. Press down on the exit cover tabs to open the exit cover on the front of the printer.

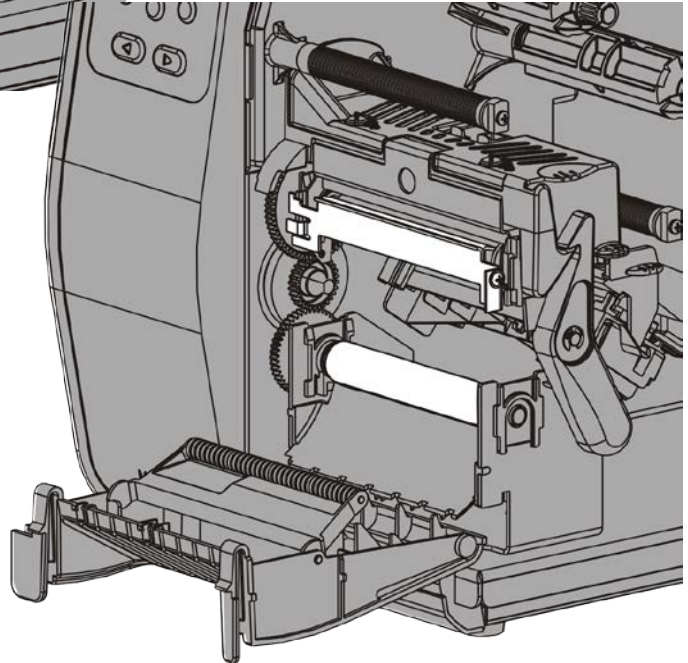
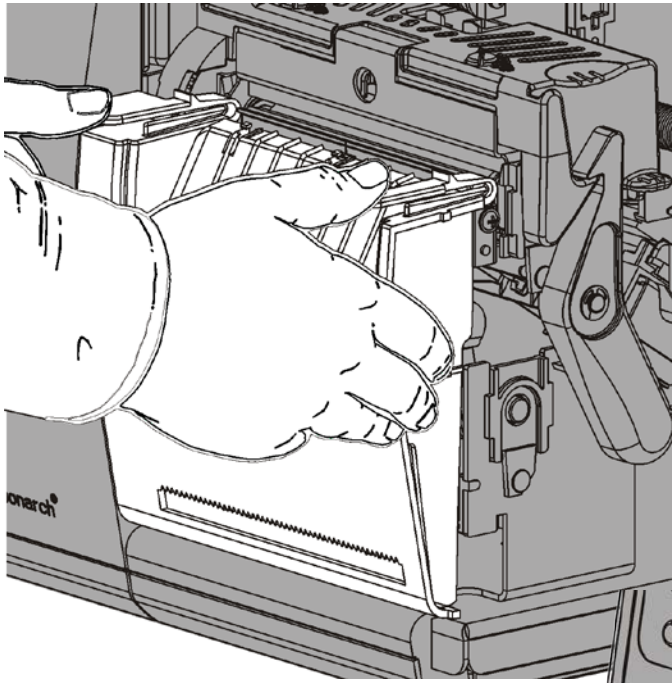

**11.**Remove the labels from the first 10 inches of the liner.

**12.**Feed the liner through the lower opening in the exit cover.

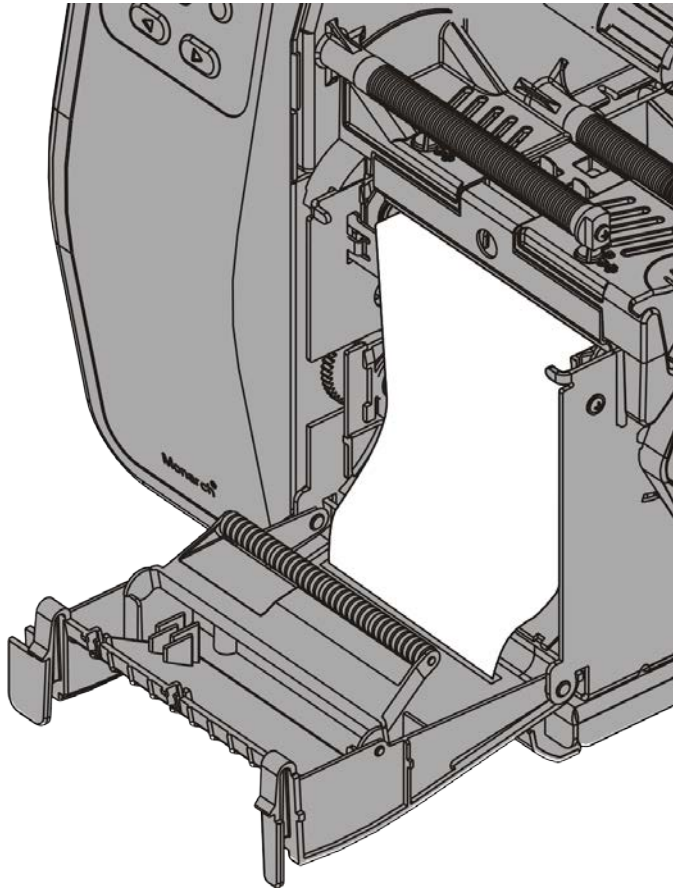

**13.**Close the exit cover.

**14.**Push the printhead release.

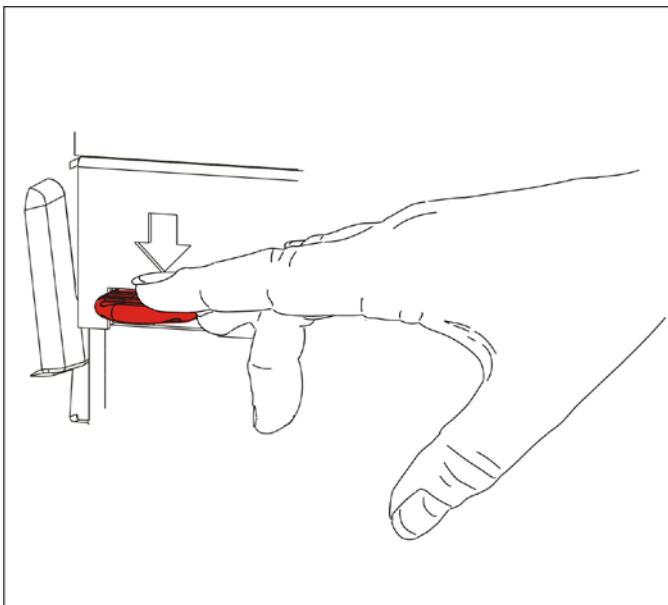

15. Close the printhead assembly until you hear it click into place.

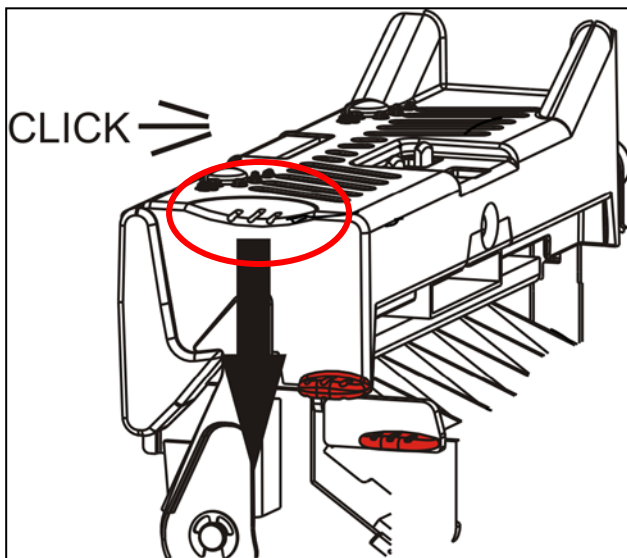

16. Close the cover.

17. Press **FEED** to position the supply under the printhead.

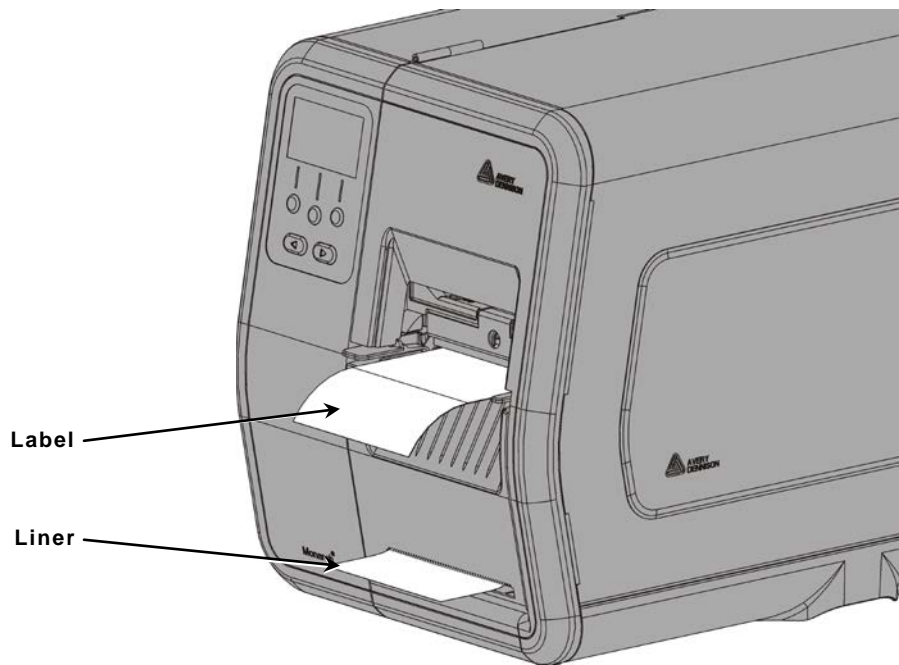

**Note:** To remove the liner, pull up across the tear edge.



## Loading Labels for Peel Mode with Liner Take-Up (Optional)

Use internal liner take-up with peel mode. Liner is collected on a take-up reel near the supply roll.

**Note:** Your System Administrator must set the printer to liner take-up (feed mode).

Remove the labels from the first 18 inches of the liner. Load supplies for peel mode, leaving at least 18 inches extending past the printhead.

1. Unlock and lift the printhead assembly until it locks into place.
2. Open the exit cover.
3. Feed the liner under the peel roller.
4. Remove the bail.
5. Wrap the liner around the take-up reel in a counter-clockwise direction.

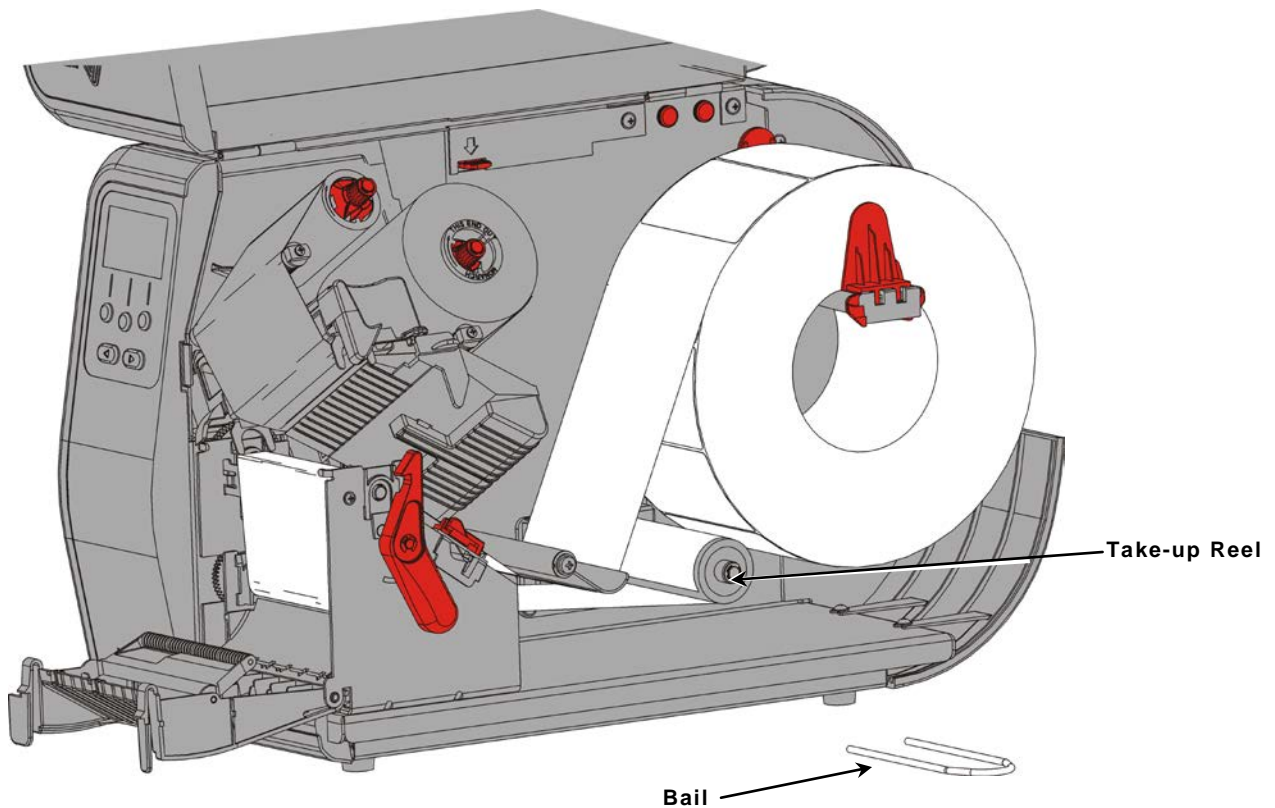
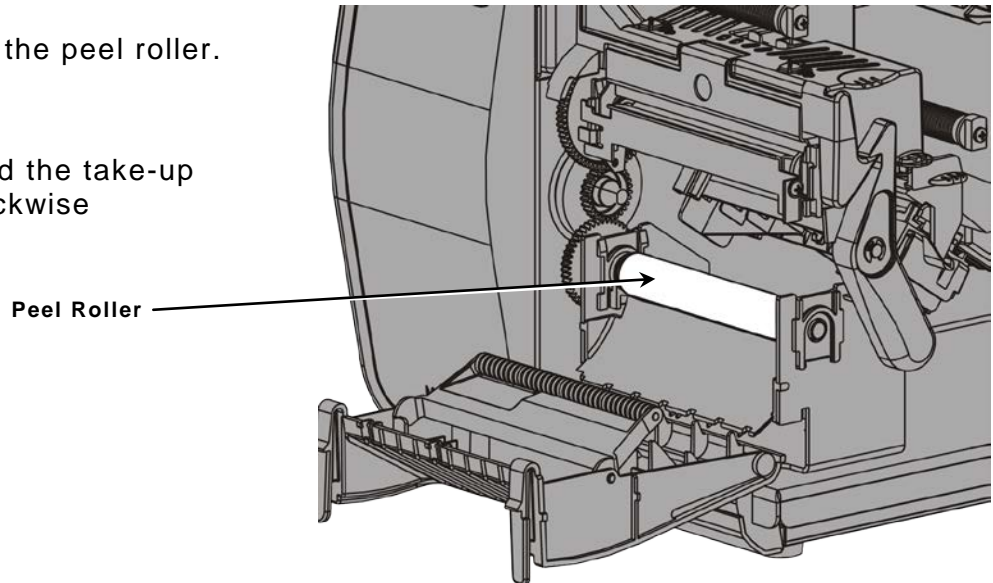

6. Hold the liner while placing one end of the bail in a groove in the liner take-up reel. Gently rotate the bail counter-clockwise until the other end snaps into the corresponding groove.

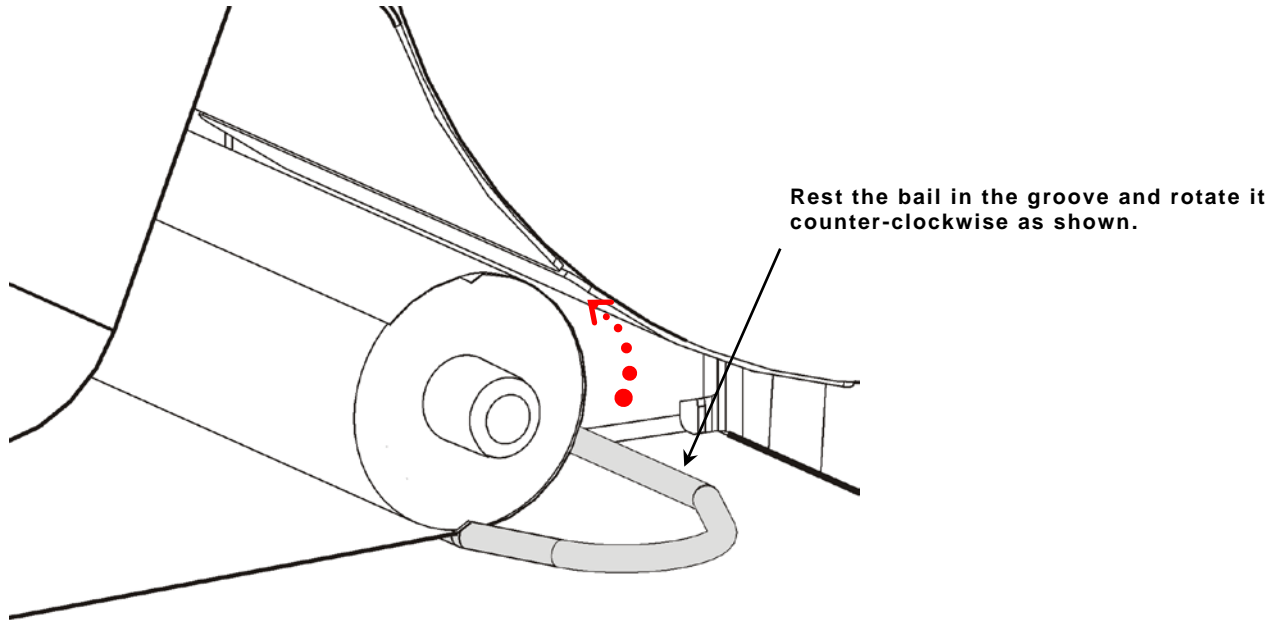

7. Gently slide the bail all the way onto the reel.
8. Turn the reel counter-clockwise to remove any slack in the liner.
9. Close the printhead assembly until you hear it click in to place.

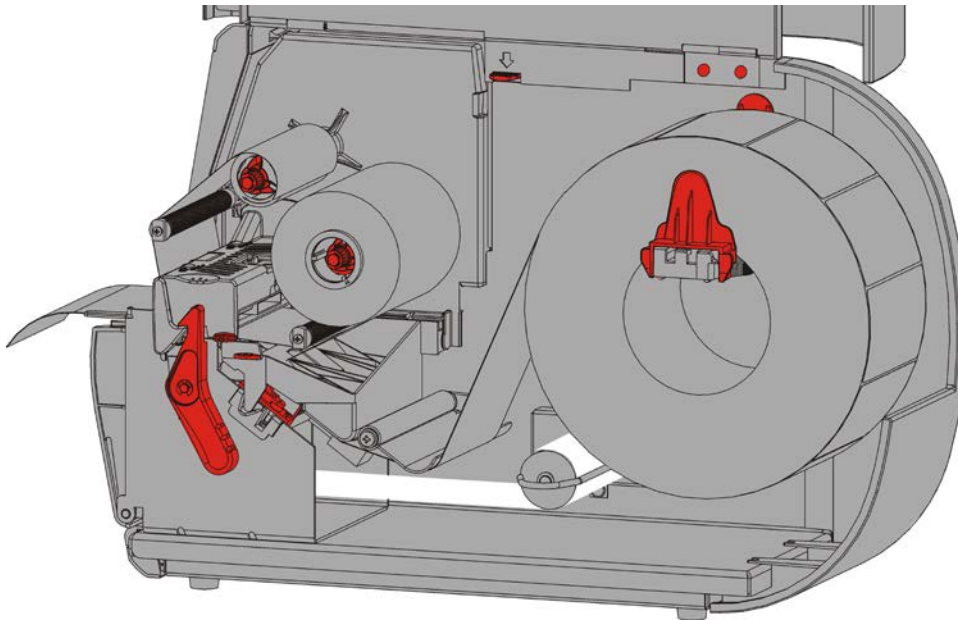

10. Close the exit cover.
11. Close the cover.
12. Press **FEED** to position the supply under the printhead.



## Removing a Full Liner Take-Up Roll

The printer alerts you when the liner take-up reel is full. The liner take-up reel holds approximately half of a roll of liner.

**Note:** The liner can be removed before the take-up reel is full.

1. Open the cover.
2. Turn the printhead latch to unlock the printhead. Lift the printhead assembly until it locks into place.
3. Open the exit cover.
4. Gently pull the liner take-up bail off the liner take-up reel.
5. Use scissors to cut the liner in front of the take-up reel.

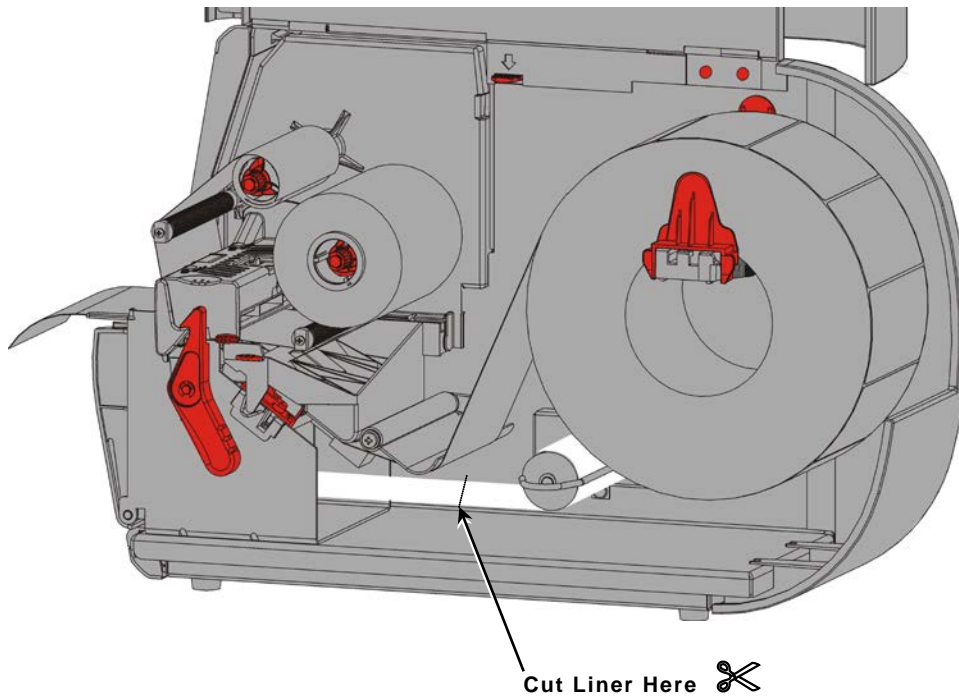

6. Remove the liner from the take-up reel.
7. Reload supply and continue printing.



# LOADING RIBBON

This chapter describes how to load ribbon.

If you are using thermal direct supplies, do not load a ribbon.

Your System Administrator must set the printer to use a ribbon.

## About Ribbons

- ◆ The ribbon cores only fit on the ribbon reels one way.
  - ◆ Use your empty ribbon core as the take-up core.
  - ◆ An extra take-up core is available by ordering part number 11796120 (2-inch), 11796130 (3-inch), or 11796140 (4-inch).
  - ◆ Ribbons unwind from a clockwise or counter-clockwise direction.
1. Open the cover.
  2. Turn the printhead latch to unlock the printhead.
  3. Lift the printhead assembly until it locks into place.

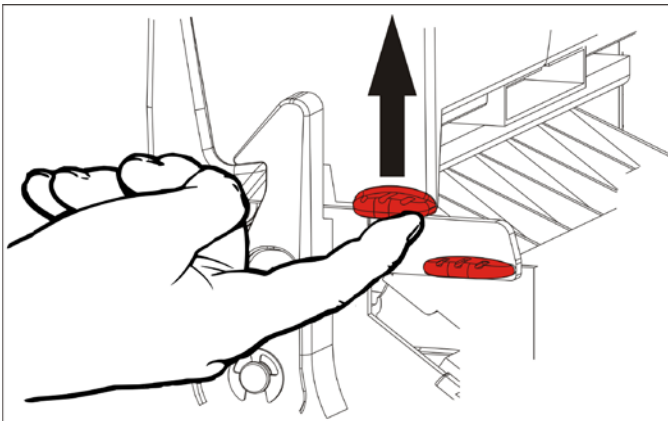

4. Push the deflector tab down.

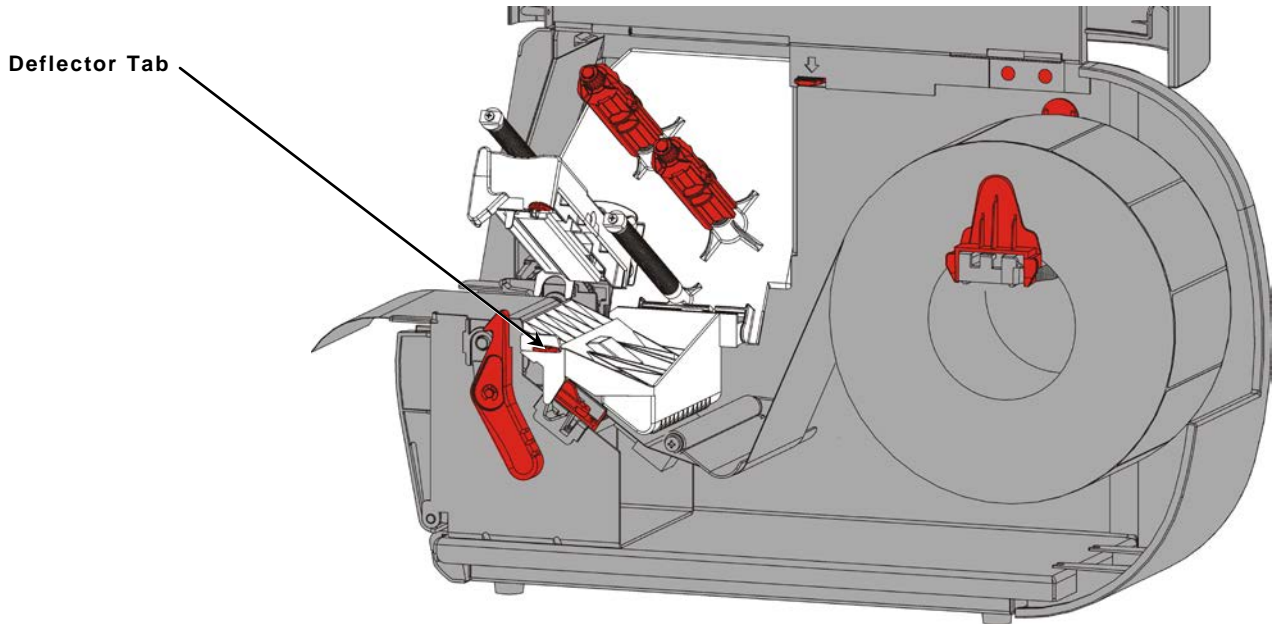

5. Slide an empty ribbon core on the take-up reel as far as it will go.
6. Remove the new ribbon from the package. Do not wrinkle or crush the ribbon.
7. Slide the ribbon onto the back reel as far as it will go. Unwind a few inches of ribbon from the roll.

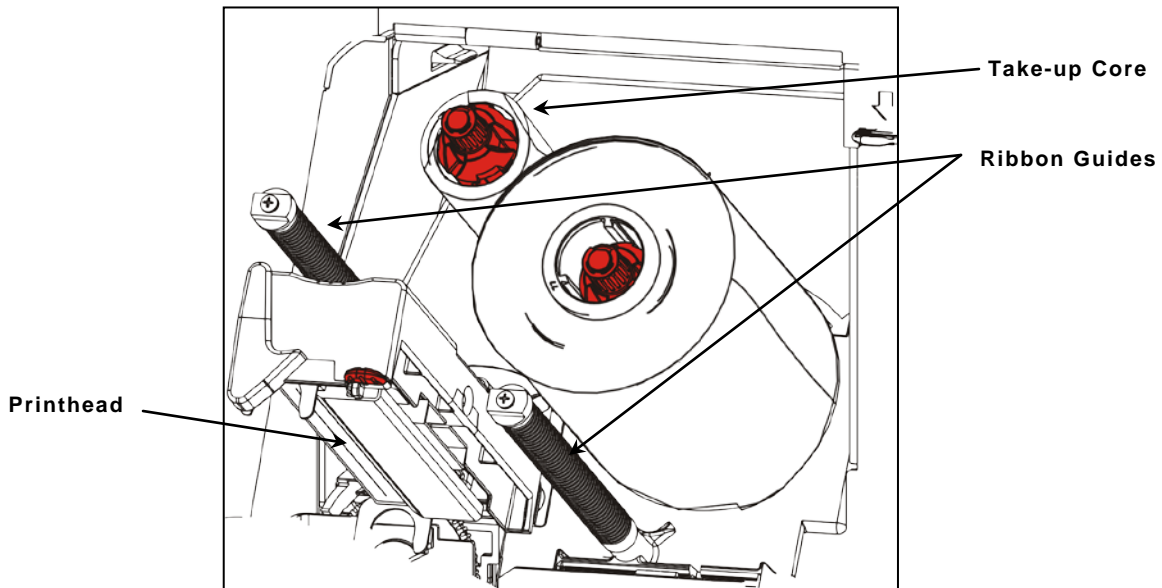

8. Carefully feed the ribbon around both ribbon guides and under the printhead.
9. Align the ribbon and make sure it is straight and centered throughout the path.

**10.** Use the adhesive on the ribbon leader to attach it to the take-up core. Make sure an empty take-up core is on the reel.

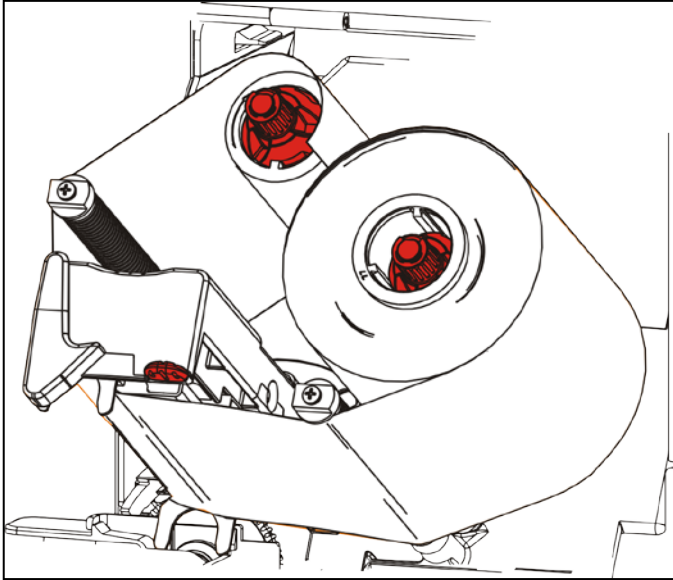

**11.** Rotate the take-up reel until the leader is past the printhead.

**12.** Remove any slack in the ribbon by turning the take-up reel until the ribbon is tight under the printhead.

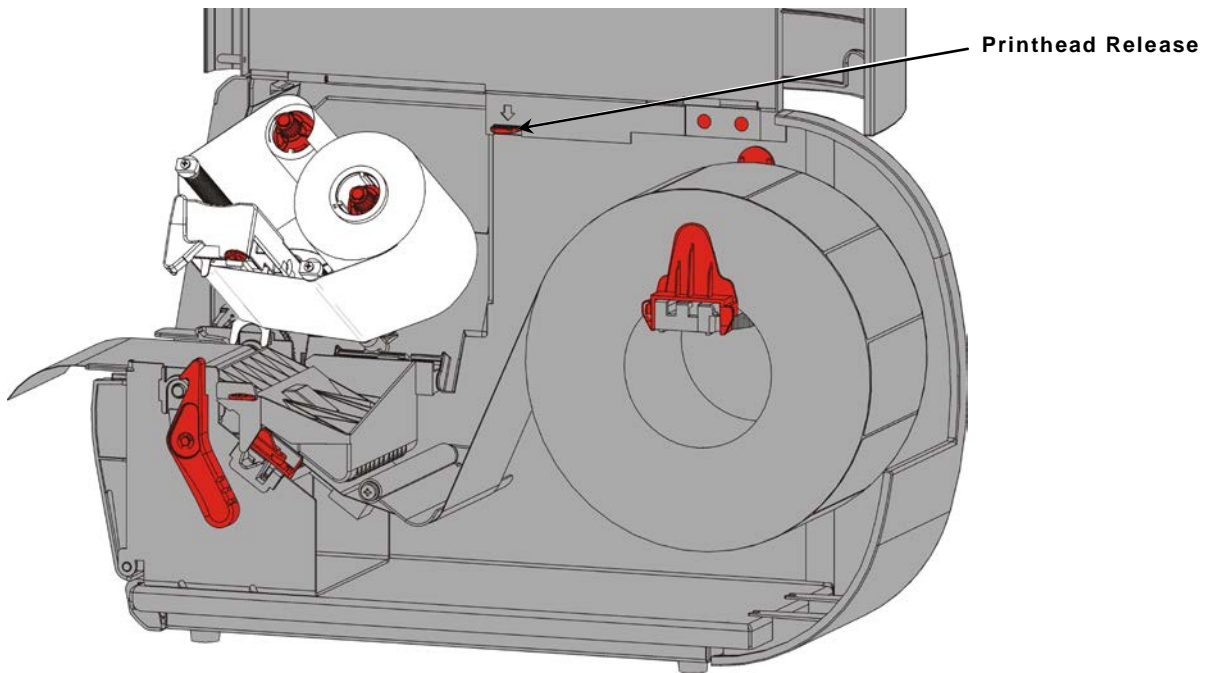

**13.** Push the printhead release.

14. Close the printhead assembly until you hear it click into place.

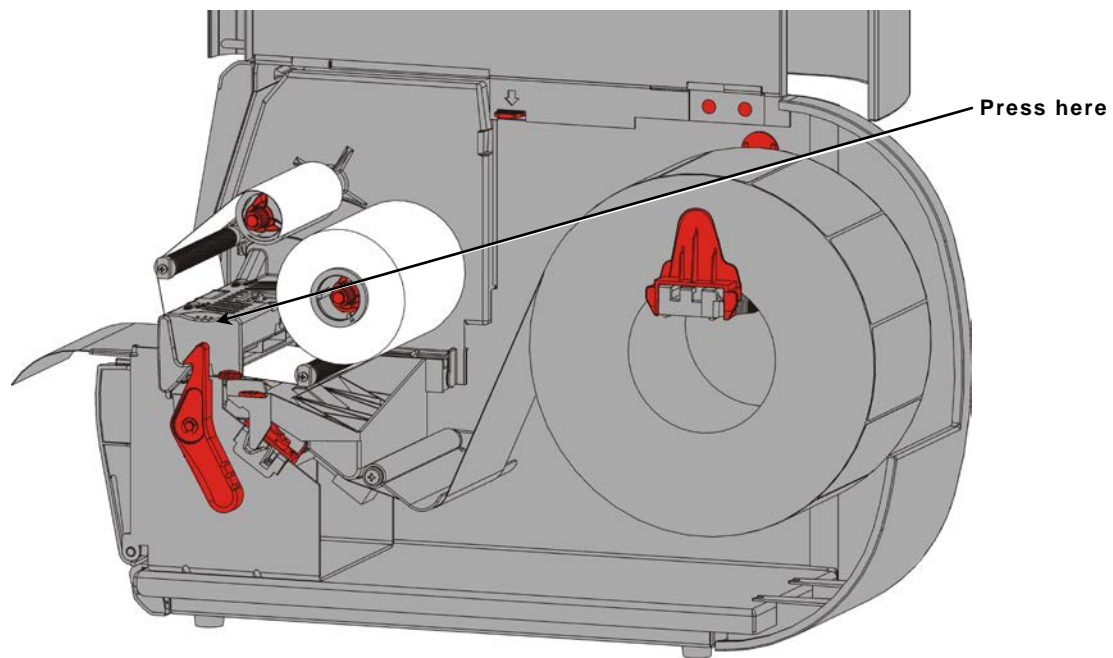

15. Close the cover.

# PRINTING

This chapter explains how to

- ◆ print, pause, cancel, and repeat a batch.

When the printer receives print data, batches begin printing automatically. Your System Administrator can use the *Packet Reference Manual* to create, store, and download the data necessary to print batches. Monarch® MPCL™ Toolbox Utilities are available on our Web site. You can also purchase label creation software.

## About RFID Supplies



RFID supplies can be damaged by static electricity. Ground yourself by touching metal, such as the printer's metal base, before handling the RFID supplies.

**Note:** Printing over the RFID inlay causes printing irregularity and may impact bar code print quality.

## Printing

Before you print

- ◆ load supply
  - ◆ connect the printer to a host (a PC or a network)
  - ◆ make sure the printer is ready to receive data.
1. Turn on the printer – it is ready when you see:

**MPCL**

**Ready**

**192. 0. 0. 192**

FEED TLABEL MENU

OR

**DATA ENTRY**

**Select Format**

**XXXXXXX**

SELECT BACK

2. Download a format and a batch.
3. The printer prints the batch (print job). Check the bar code print quality.

A bar code that is in spec has complete bars, clear spaces, and small alphanumeric characters look complete. An in spec bar code may not look as good as one that is too dark, but it has the highest scan rate. If the print is too dark/light or there are voids, see [“Adjusting the Print Quality”](#) for more information.

**ROADWAY SYSTEMS**



DAYTON, OHIO

Dark

**BROADWAY SYSTEMS**



DAYTON, OHIO

IN SPEC

**BROADWAY SYSTEMS**



DAYTON, OHIO

Light

## Pausing While Printing

---

1. Press **PAUSE** to interrupt printing. The LCD is green.

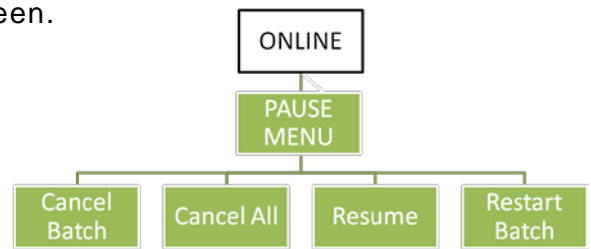
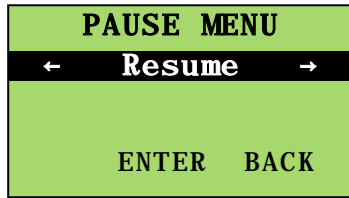

2. Press **ENTER** to resume printing the current batch **OR** press **←** or **→** to display the Pause Menu options:

Select	To
Cancel Batch	Cancel the currently printing batch.
Cancel All	Cancel all batches (jobs) in the print queue.
Resume	Continue printing the current batch.
Restart Batch	Reprint a paused batch from the beginning (using the original quantity).

## Canceling Printing

---

Press **ESCAPE** anytime while the batch is printing or press **PAUSE**, select **Cancel Batch**, and press **ENTER**.

## Repeating a Batch

---

Before you start printing a new batch, you can reprint the last batch. The batch can be either the last one you printed completely or one that you canceled after starting to print.

1. *From the Main Menu*, press **←** or **→** until you see

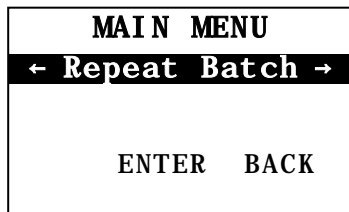

2. Press **ENTER** to reprint the last batch. The number increments until the entire batch is printed.



This chapter tells you how to

- ◆ clear label jams and clean the printer.
- ◆ replace a printhead.

**CAUTION:** Do not use sharp objects to clean the printhead or touch the printhead with your fingers. This may damage the printer and require a service charge.

## Clearing Label Jams

---

When a jam occurs, you see

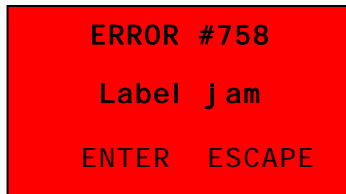
A red rectangular box with white text. The text is centered and reads: "ERROR #758", "Label jam", and "ENTER ESCAPE" on three separate lines.

ERROR #758  
Label jam  
ENTER ESCAPE

To clear the jam:

1. Open the cover and printhead assembly.
2. If necessary, remove the label roll and ribbon.
3. Remove the jammed labels.
4. Reload the label roll and/or ribbon.
5. Close the printhead assembly.
6. Press **ENTER** to clear the error.
7. Press **FEED** to position the supply under the printhead.

## Cleaning

Clean the printhead, peel bar, sensor, and platen roller:

- ◆ when there is any adhesive build-up in the supply path.
- ◆ after printing approximately three rolls of thermal transfer/thermal direct supplies or after each ribbon.
- ◆ daily if your printer is in an excessively dirty, hot, or humid environment.
- ◆ if there are voids or streaking in the print as shown.



Voids



Streaks

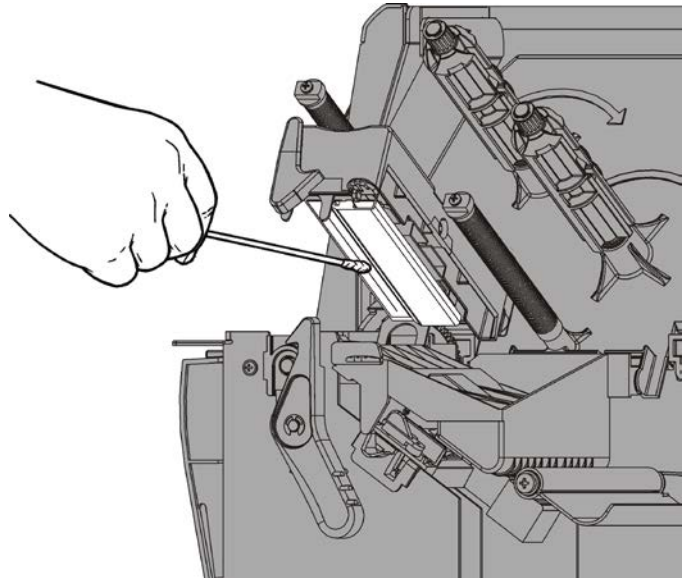

1. Turn off the printer, open the cover and printhead assembly.
2. Remove the supply roll and ribbon.
3. Press down on the exit cover tabs to open the exit cover on the front of the printer.
4. Spray the supply path and sensor with compressed air to remove dust and debris.
5. Use a cotton swab moistened with isopropyl alcohol to clean the printhead, peel bar, sensor, and platen roller when you see significant adhesive build-up or after clearing a jammed label.

**Note:** Use a printhead CLEAN STRIP (120350) if the printhead is extremely dirty or you see streaks on the supply.

6. Turn the platen roller with your finger to make sure it is clean all the way around.

**Caution:** Do not use solvent-based cleaners containing naphtha or petroleum distillates on the platen roller. Only use isopropyl alcohol or mild soap and water.

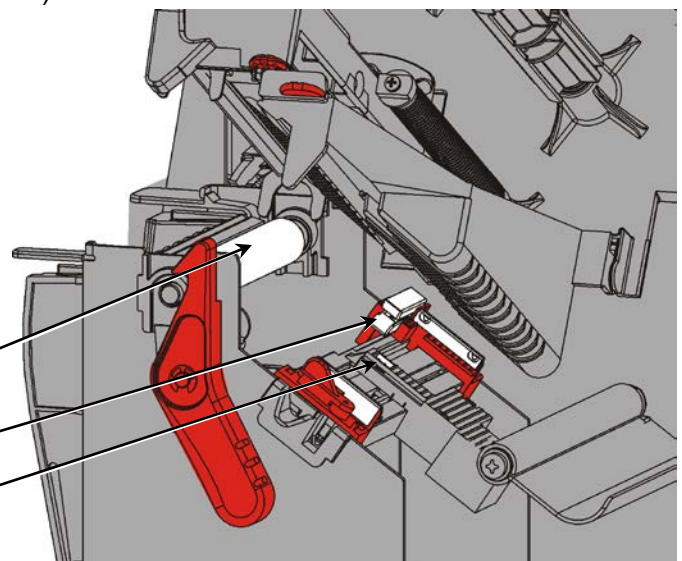
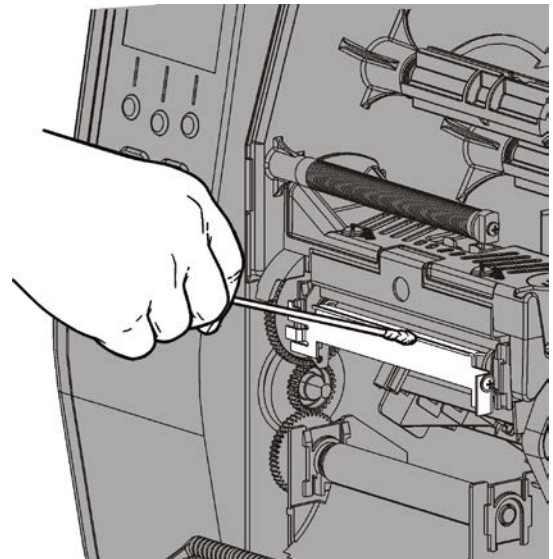

Platen Roller

Die Cut Sensor

Supply Sensor

7. Once the printer is dry, reload the ribbon and supply roll.
8. Close the exit cover by pushing firmly on it. Both latches click into place.
9. Close the printhead assembly and cover.
10. Turn on the printer.
11. Press **FEED** to position the supply under the printhead.

## Replacing the Printhead

---

Replace the printhead when it is damaged or worn-out.

**CAUTION:** Static electricity can damage the printhead. Ground yourself by touching metal, such as the printer's metal base, before touching the printhead. Clean the printhead prior to operation to remove any salt or oil left from handling.



1. Turn off the printer.
2. Open the cover.
3. Turn the printhead latch to unlock the printhead.
4. Lift the printhead assembly until it locks into place.
5. Remove the ribbon and supply.
6. Press forward and down on the two printhead assembly latches. The printhead drops down.

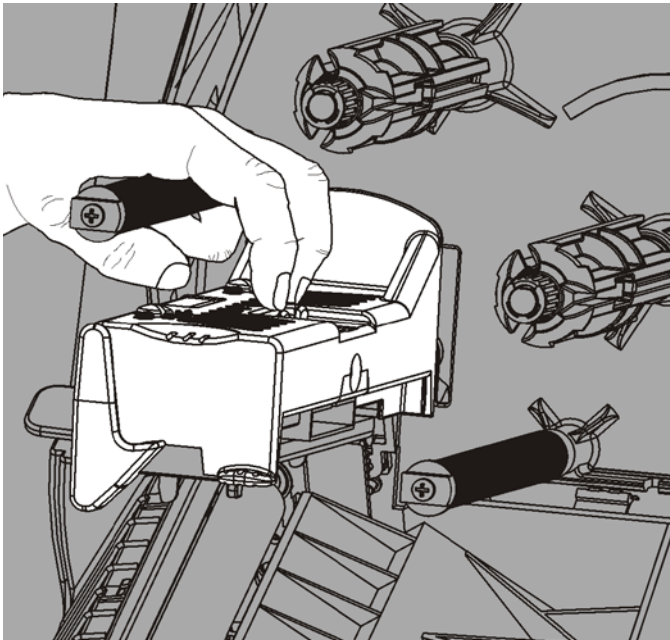

7. Carefully unplug the cable from the printhead.
8. Carefully plug the cable into the new printhead.

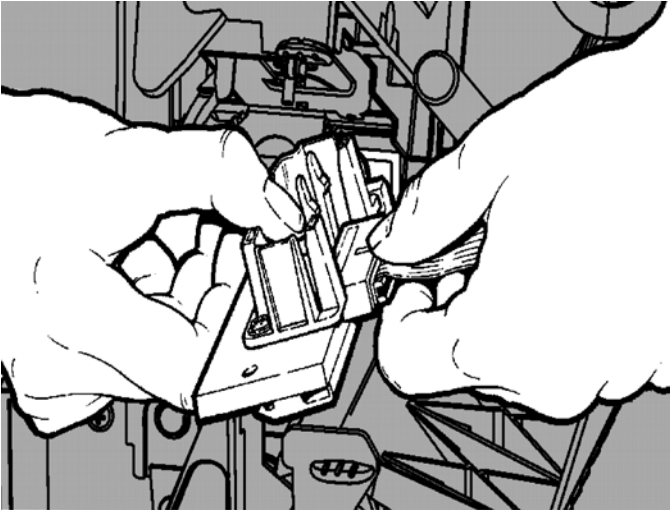

9. Align the new printhead with the tabs.
10. Snap the printhead into place.

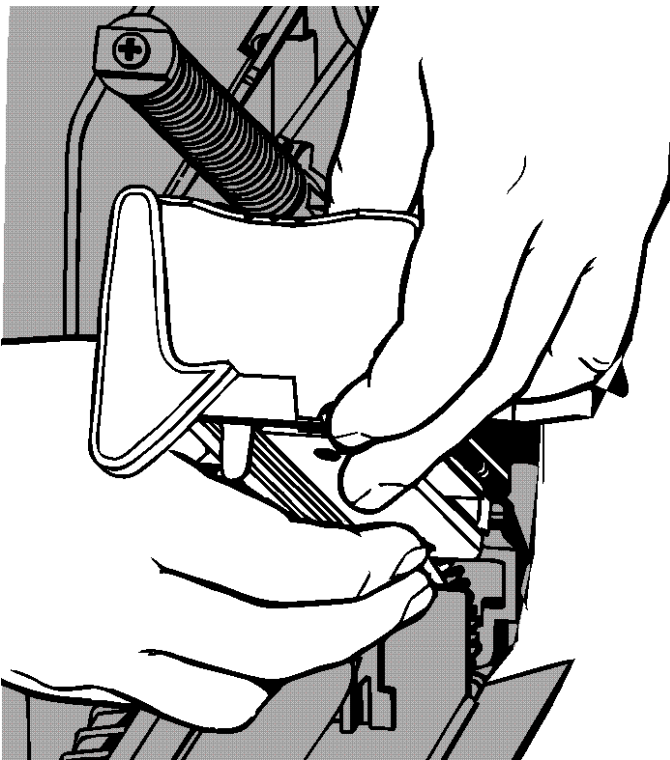

**Note:** Make sure the printhead cable does not touch the ribbon roll.

11. Clean the new printhead with a cotton swab dipped in isopropyl alcohol.
12. Let the printhead dry and reload your supplies.
13. Close the printhead assembly and cover.
14. Turn on the printer.
15. Press **FEED** to position the supply under the printhead.

This chapter explains how to adjust print quality and contains basic troubleshooting information.

If you need to call Technical Support, print a test label first. See “Printing a Test Label” in Chapter 1 for more information.

## Adjusting the Print Quality

---

Many factors impact print quality: type of supplies, print speed, print contrast, and the type of printer application. The printer supports both thermal transfer and thermal direct supplies. The type of supply should match the printer’s application.

- ◆ Use premium supplies if you want to print at high speeds.
- ◆ Select the print speed based on desired throughput and print quality. If print quality is more important, reduce the print speed. A lower print speed increases the print quality of labels. If throughput is more important, increase the print speed.
- ◆ If the print quality is too light or too dark, adjust the print contrast or the printhead pressure dials.

### Setting the Print Contrast

Having the correct print contrast setting is important because it affects how well your bar codes scan and how long your printhead lasts.

To change the print contrast:

1. Press **MENU**.
2. Press **←** or **→** until you see **SETUP**. Press **SELECT**.
3. Press **←** or **→** until you see **CONTRAST**. Press **SELECT**.

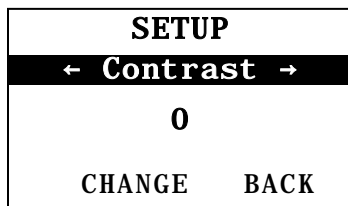

4. Press **CHANGE**. The current setting is shown.

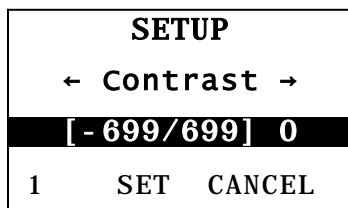

5. Press **←** or **→** to increase or decrease the contrast. Increasing the contrast setting darkens the print; decreasing the contrast setting lightens the print.

**Note:** Press the left function button to change the amount (adjusts to change by 1, 10, or 100).

6. When you see the contrast setting you need on the display, press **SET** to save.
7. Press **BACK** until you see “Ready,” then press **SELECT**.

## Adjusting the Printhead Pressure Dials

Two dials are located on either edge of the printhead assembly. Use a coin or flathead screwdriver to adjust the dials *based on the width of your supply*. The “out of the box” setting (default) is least pressure, which provides optimal printing in most cases.

If you see smudging, ribbon wrinkling, or poor print quality, adjust the printhead pressure dials.

**Note:** Both dials must be set to the same position.

Knob is set to least pressure adjustment (knobs are up).

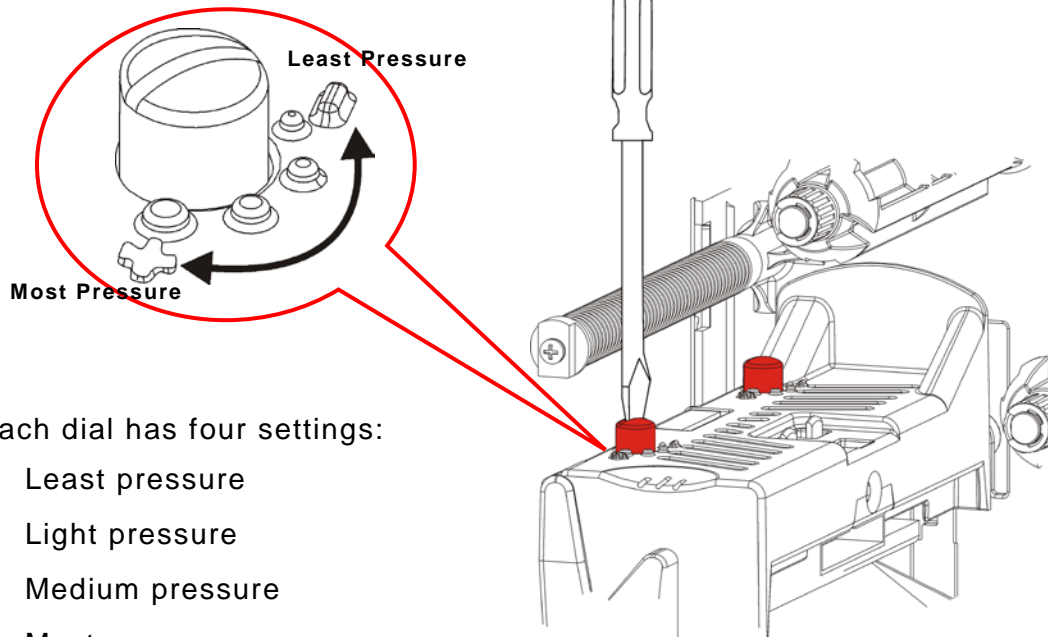

Each dial has four settings:

- ◆ Least pressure
- ◆ Light pressure
- ◆ Medium pressure
- ◆ Most pressure

Use the following guidelines to adjust the printhead pressure. Check print quality and repeat if necessary.

Supply Width	Dial Settings
Wide supply (> 2 inches)	Increase both dials one step.
Narrow supply (≤ 2 inches)	Decrease both dials one step.

If print quality does not improve,  
Contact Technical Support.

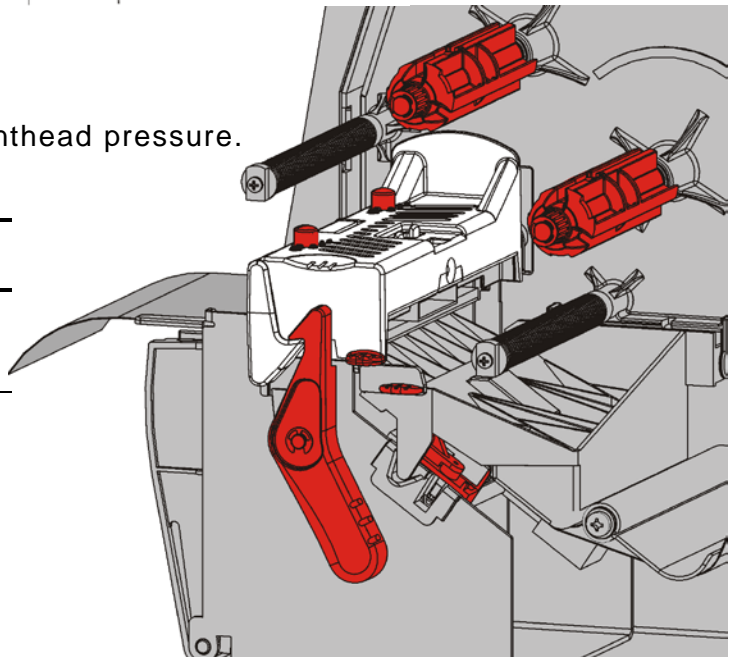

## Troubleshooting

---

Use this information to solve some common problems.

<b>Problem</b>	<b>Action</b>
Does not print.	Check supply. Check ribbon. Press feed. Check connection to host.
Does not feed.	Check supply. Check ribbon. Clear jam. Close printhead completely.
Partially printed data.	Clean the printhead. Resend the batch (print job).
Light/Dark printing or voids in print.	Clean the printhead. Change supply. Adjust the print contrast. See " <a href="#">Setting the Print Contrast.</a> " Adjust the printhead pressure dials. See " <a href="#">Adjusting the Printhead Pressure Dials.</a> " Check ribbon.
Serial bar codes print with voids or do not scan.	Adjust the print contrast. See " <a href="#">Setting the Print Contrast.</a> " Your System Administrator can change the print speed to 2.5 IPS.
Liner is wrapped around platen roller.	Clear the jam. Clean the platen roller. Leave the printhead unlatched when printer is unused for extended periods of time.
Blank labels print.	Your System Administrator should check the format. It may not be designed for the loaded supply size.

If you cannot fix a problem, call Customer Service.



## Error Messages

Contact your System Administrator if you cannot clear an error or you see an error not listed below.

Many of these errors require action by your *System Administrator*.

**ERROR #756**

**Load supplies**

**ENTER ESCAPE**

<b>Error</b>	<b>Action</b>
411	Make sure the printer's communication values match those at the host.
614	Portion of field off tag or check for invalid characters in the data packets. Check with your System Administrator.
616	A bar code on the label did not print (dot shifting failed). Check with your System Administrator or check/replace the printhead.
703 704	Check/load supply. The printer's supply type must match the loaded supply. For example, the printer is set for die cut supply, but black mark supply is loaded.
741 743	Check supply loading and the settings in the Monarch® RFID Printer Setup Utility.
750	Turn off the printer to let the printhead cool down.
751 752 753	Check/load supply. Press <b>ENTER</b> to continue printing. Clean sensor.
754	Check/load ribbon. Press <b>ENTER</b> to continue printing.
755	Close the printhead to continue.
756	Load supply. Press <b>ENTER</b> to continue printing.
758	Check for a label jam, clear the supply path, or reload supplies. This error may occur if you remove a label too quickly in the on-demand mode.
763	Waiting to dispense label. Press <b>FEED</b> .
765 768	Check/replace the printhead. Press <b>ENTER</b> to continue.
785 786	Remove the liner from the take-up core. Reload supply for liner take-up. Press <b>ENTER</b> to continue.

**Note:** If the above actions do not clear the error, turn off the printer, wait several seconds and then turn on the printer.



# SPECIFICATIONS

A

## Printer

---

<b>Height:</b>	13.8 inches (351.1 mm)
<b>Width:</b>	11.6 inches (293.5 mm)
<b>Depth:</b>	21.7 inches (550.8 mm)
<b>Weight:</b>	33 lb. (15 kg)
<b>Shipping Weight:</b>	38 lb. (17.3 kg)
<b>Power Source:</b>	100-240 V <sub>AC</sub> , 50-60Hz
<b>Power Consumption: (per printer)</b>	<i>Standard printer:</i> 1.3A maximum at 110V 0.6A maximum at 220V <i>Cutter-ready printer:</i> 1.7A maximum at 110V 0.8A maximum at 110V
<b>Operating Limits:</b>	Thermal Transfer (ribbon): 40° to 95°F (4° to 35°C) Thermal Direct: 40° to 104°F (4° to 40°C) Storage: 15°F to 120°F (-10°C to 49°C) Humidity: 5% to 90% non-condensing
<b>Printhead:</b>	Thermal at 4.09 inches (103 mm) wide 203 dpi (8.0 dots per mm)
<b>Printing Method:</b>	Thermal Transfer (ribbon) or Thermal Direct
<b>Print Speed:</b>	2.5 ips (64 mm) default for all serial bar codes, 4.0 ips (102 mm), 6.0 ips (152 mm), 8.0 ips (203mm), 10.0 ips (254 mm), or 12.0 ips (305 mm)
<b>Max Print Area:</b>	4.09 inches x 20.0 inches (102 mm x 508 mm)

## Supplies (Media)

---

<b>Supply Widths:</b>	0.75 inches (19 mm) minimum for labels and tags 4.32 inches (108 mm) maximum for labels and tags
<b>Supply Lengths:</b>	0.32 inch (8 mm) minimum for non-peel mode 1.50 inches (38 mm) for peel mode  17.5 inches (444.5 mm) maximum for labels and tags 20 inches (508 mm) maximum  0.75 inch (19 mm) minimum for tags 1.2 inches (30 mm) minimum for cutting tags
<b>Total Thickness:</b>	5 to 14 mils
<b>Max. Roll Diameter:</b>	9.375 inches (238 mm)
<b>Supply Core:</b>	3.0 inches (76 mm) minimum 4.0 inches (101.6 mm) maximum

For string tag specifications, refer to the *System Administrator's Guide*.

## Ribbon

---

Do not leave ribbon in sunlight, high temperatures or humidity.

<b>Ribbon Type:</b>	Standard (wax, high speed) Premium (wax resin, TUFF-MARK® resin)
---------------------	---

<b>Ribbon Widths</b>	<b>Use with Maximum supply width</b>
1.5 inches (38 mm)	1.3 inches (33 mm)
1.8 inches (46 mm)	1.5 inches (38 mm)
2.3 inches (58 mm)	2.0 inches (51 mm)
3.3 inches (84 mm)	3.0 inches (76 mm)
4.3 inches (110 mm)	4.0 inches (102 mm)

**Note:** Use a ribbon wider than your supply.

<b>Ribbon Length:</b>	23,600 inches (600 meters)
-----------------------	----------------------------



**AMERICAS**

170 Monarch Lane  
Miamisburg, OH 45342  
937 865 2123 (direct)  
Tel +800 543 6650  
(8:00 a.m. – 6:30 p.m., EDT)  
Fax +937 865 6663

**ASIA**

No. 7 Chun Ying Street  
Tseung Kwan O Industrial Estate  
New Territories, Hong Kong  
Tel +852 2372 3169  
Fax +852 2995 0014

**WESTERN EUROPE**

1 Thomas Road  
Wooburn Green  
Bucks HP10 0PE  
Tel +(44) 1628 859500  
Fax +(44) 1628 859567

**ASIA PACIFIC****NEW SOUTH WALES**

61 Vore Street  
Silverwater NSW 2128  
Tel +(02) 9647 1833  
Fax +(02) 9647 1914  
Toll free (Outside Sydney only)



Retail Branding and  
Information Solutions